



ORIGINAL INSTRUCTIONS  
**Compound Mitre Saw**

CMS180G





## **Important!**

It is essential that you read the instructions in this manual before operating this machine.

Subject to technical modifications.





## GENERAL SAFETY WARNINGS

### WARNING

When using electric tools, basic safety precautions should always be followed to reduce the risk of fire, electric shock and personal injury. Read all these instructions before attempting to operate this product and save these instructions.

- **Keep work area clear.** Cluttered areas and benches invite injuries.
- **Consider work area environment.** Do not expose tools to rain. Do not use tools in damp or wet locations. Keep work area well lit. Do not use tools in the presence of flammable liquids or gases.
- **Guard against electric shock.** Avoid body contact with earthed or grounded surfaces (e.g., pipes, radiators, ranges, refrigerators).
- **Keep other persons away.** Do not let persons, especially children, be involved in the work, touch the tool or the extension cord, and keep them away from the work area.
- **Store idle tools.** When not in use, tools should be stored in a dry locked-up place, out of reach of children.
- **Do not force the tool.** It will do the job better and safer at the rate for which it was intended.
- **Use the right tool.** Do not force small tools to do the job of a heavy duty tool. Do not use tools for purposes not intended, for example, do not use circular saws to cut tree limbs or logs.
- **Dress properly.** Do not wear loose clothing or jewellery, they can be caught in moving parts. Non-skid footwear is recommended when working outdoors. Wear protective hair covering to contain long hair.
- **Use protective equipment.** Use safety glasses. Use face or dust mask if working operations create dust.
- **Connect dust extraction equipment.** If the tool is provided for the connection of dust extraction and collecting equipment, ensure these are connected and properly used.
- **Do not abuse the cord.** Never yank the cord to disconnect it from the socket. Keep the cord away from heat, oil and sharp edges.
- **Secure work.** Where possible, use clamps or a vice to hold the work. It is safer than using your hand.
- **Do not overreach.** Keep proper footing and balance at all times.
- **Maintain tools with care.** Keep cutting tools sharp and clean for better and safer performance. Follow instruction for lubricating and changing accessories. Inspect tool cords periodically and if damaged, have them repaired by an authorized service facility. Inspect extension cords periodically and replace if damaged. Keep handles dry, clean and free from oil and grease.

- **Disconnect tools.** When not in use, before servicing and when changing accessories such as blades, bits and cutters, disconnect tools from the power supply.
- **Remove adjusting keys and wrenches.** Form the habit of checking to see that keys and adjusting wrenches are removed from the tool before turning it on.
- **Avoid unintentional starting.** Ensure switch is in "off" position when installing battery pack.
- **Use outdoor extension leads.** When the tool is used outdoors, use only extension cords intended for outdoor use and so marked.
- **Stay alert.** Watch what you are doing, use common sense and do not operate the tool when you are tired.
- **Check damaged parts.** Before further use of tool, it should be carefully checked to determine that it will operate properly and perform its intended function. Check for alignment of moving parts, binding of moving parts, breakage of parts, mounting and any other conditions that may affect its operation. A guard or other part that is damaged should be properly repaired or replaced by an authorized service centre unless otherwise indicated in this instruction manual. Have defective switches replaced by an authorized service centre. Do not use the tool if the switch does not turn it on and off.
- **Warning.** The use of any accessory or attachment other than the one recommended in this instruction manual may present a risk of personal injury.
- **Have your tool repaired by a qualified person.** This electric tool complies with the relevant safety rules. Repairs should only be carried out by qualified persons using original spare parts otherwise this may result in considerable danger to the user.

## SPECIAL SAFETY RULES

### WARNING

The product is not intended for use by persons (including children) with reduced physical, sensory or mental capabilities, or lack of experience and knowledge, unless they have been given supervision or instruction concerning use of the product by a person responsible for their safety.

Children should be supervised to ensure that they do not play with the product.

- Wear ear protectors. Exposure to noise can cause hearing loss.
- Always wear goggles when using the machine. It is recommended to wear gloves, sturdy non slipping shoes and apron.
- Always disconnect the battery pack before carrying out any work on the machine.
- Only install and remove the battery pack when machine



is switched off.

- Sawdust and splinters must not be removed while the machine is running.
- Never reach into the danger area of the plane of the blade when it is running.
- Repairs should only be carried out by authorised service agents.
- Always use the protective shields on the machine.
- Do not clamp the protective swing guard.
- Do not use saw blades which are damaged or deformed.
- Replace the table insert when worn.
- Do not use saw blades not corresponding to the key data given in these instructions for use.
- The protective cover should only open when the machine is lowered to the workpiece.
- Do not use saw blades made of high-speed steel.
- Any faults with the machine, including any related to the safeguard or the saw blades, must be reported to the persons in charge of safety as soon as the faults are discovered.
- It is necessary to select a saw blade which is suitable for the material being cut.
- Never use the mitre saw to cut materials other than those specified in the instruction manual.
- The handle lock must always be engaged when transporting the mitre saw.
- Only use the saw with guards in good working order and properly maintained, and in position.
- Keep the floor area free of loose material e.g., chips and cut-offs.
- Only use saw blades which have been properly sharpened. It is essential to adhere to the maximum speed specified on the saw blade.
- Do not use any flanges other than those supplied or indicated in the instruction manual to secure the saw blade.
- Refrain from removing any cut-offs or other parts of the workpiece from the cutting area whilst the machine is running and the saw head is not in the rest position.
- Ensure that the machine is always stable and secure (e.g., fixed to a bench).
- Long workpieces must be adequately supported.
- Do not use cracked or distorted saw blades.
- Before using the tool please read the instructions. If possible have the tool demonstrated.
- The dust produced when using this tool may be harmful to health. Use a dust absorption system and wear a suitable dust protection mask. Remove deposited dust thoroughly, e.g., with a vacuum cleaner.
- Stock having a round or irregular cross section (such as firewood) must not be cut, as it cannot be securely held during cutting. When sawing thin stock layered on edge, a suitable auxiliary fence must be used for firm

support.

- Use of controls or adjustments or performance of procedures other than those specified herein may result in hazardous radiation exposure.
- Do not stare directly at the laser beam.
- Always wear safety goggles or safety glasses with side shields during power tool operation or when blowing dust. If operation is dusty, also wear a dust mask.
- Any repairs must only be carried out by the laser manufacturer or authorized service agent.
- Do not replace the laser with a different type.

## INTENDED USE

- The mitre saw can be used for sawing solid wood, bonded wood, glued veneer, materials similar to wood, and plastics.
- Do not use this product in any other way as stated for normal use.

## LASER SAFETY

- Do not stare into beam during operation.
- Do not project the laser beam directly into the eyes of others. Serious eye injury could result.
- Do not place the laser in a position, that may cause anyone to stare into the laser beam intentionally or unintentionally.
- Do not use optical tools to view the laser beam.
- Do not operate the laser around children or allow children to operate the laser.
- Do not attempt to repair the laser device by yourself.
- Do not attempt to change any parts of the laser device by yourself.
- Any repairs must only be carried out by the laser manufacturer or authorized service agent.
- Do not replace the laser with a different type.

## ENVIRONMENTAL PROTECTION



Recycle raw materials instead of disposing of as waste. The machine, accessories and packaging should be sorted for environmental-friendly recycling.

## SYMBOL



Safety alert

V

Volts



Hz Hertz

~ Alternating current

W Watts

$n_0$  No-load speed

$\text{min}^{-1}$  Revolutions or reciprocations per minute

 CE conformity



Please read the instructions carefully before starting the machine.



Wear ear protection



Wear eye protection



Danger! Sharp blade.



Laser radiation.  
Do not stare into beam.



Waste electrical products should not be disposed of with household waste. Please recycle where facilities exist. Check with your Local Authority or retailer for recycling advice.

# Unpacking

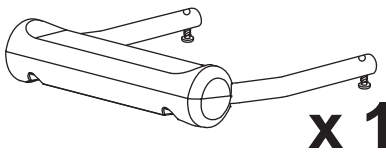
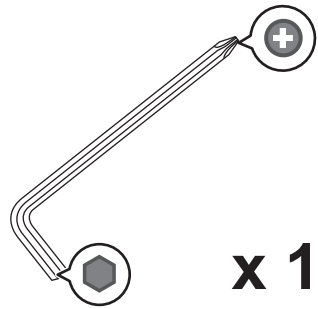
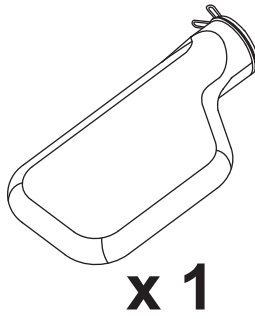
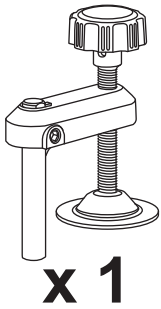
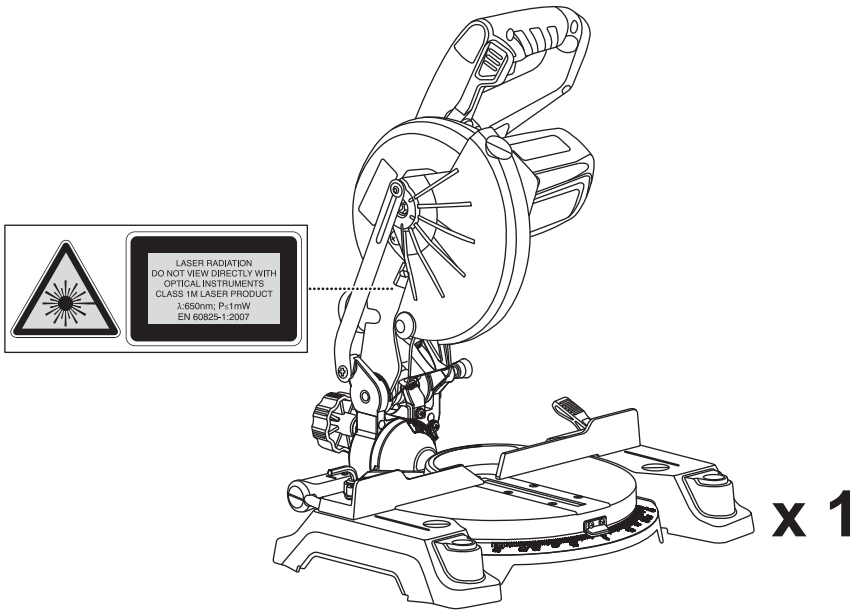

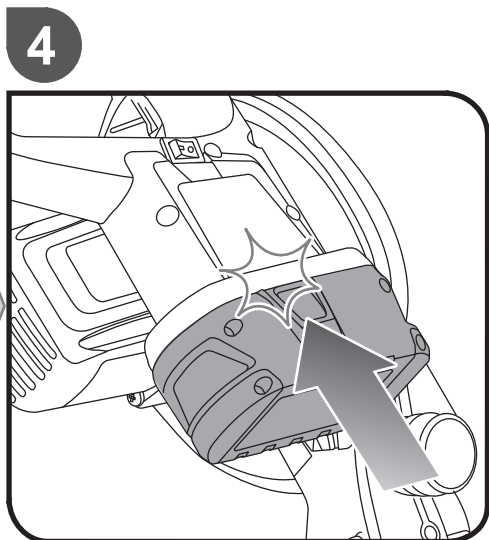
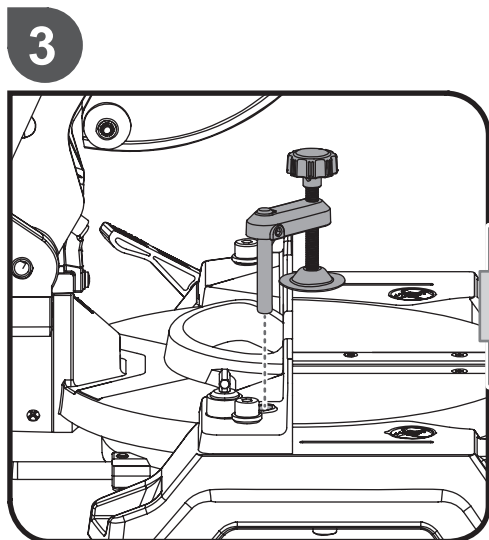
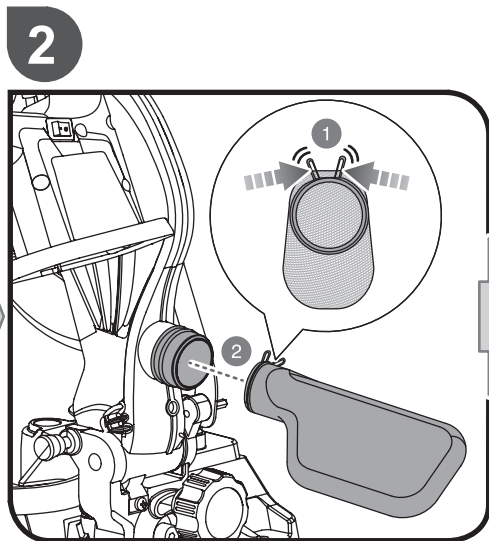
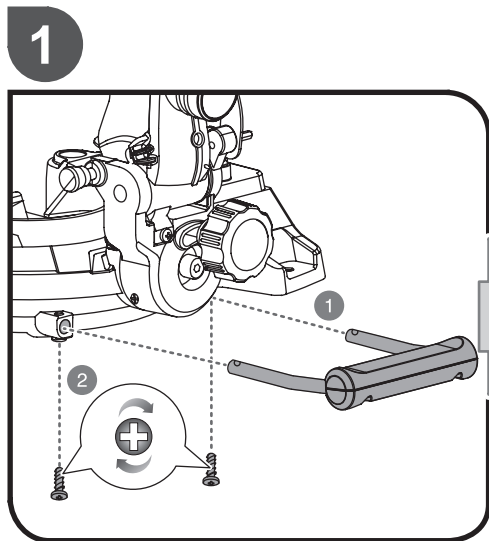



# Operation

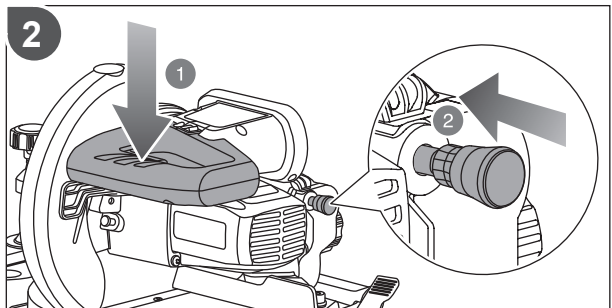
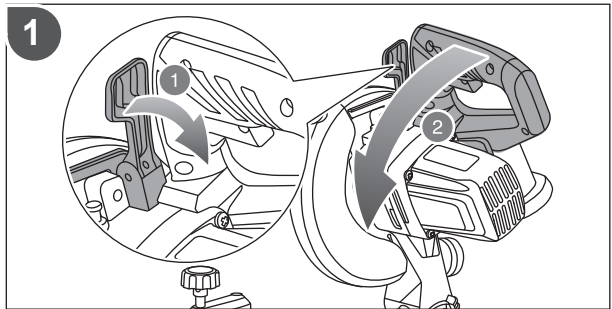
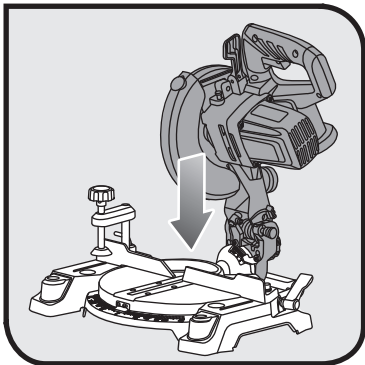
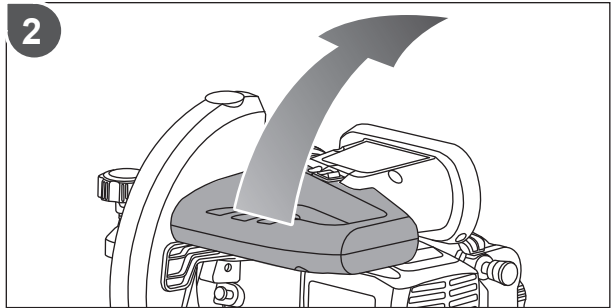
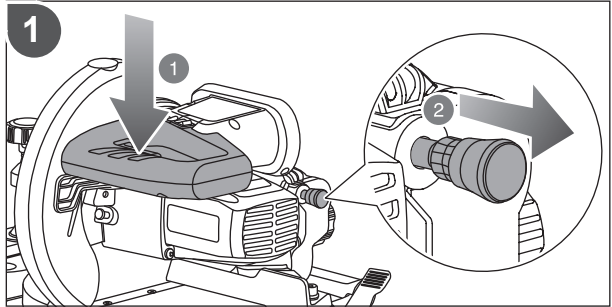
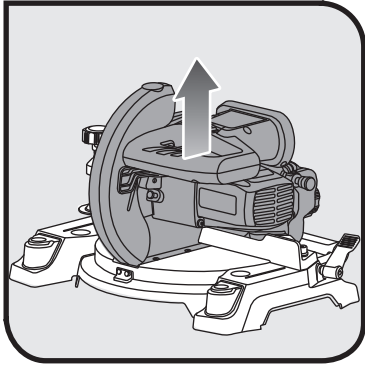





# Operation

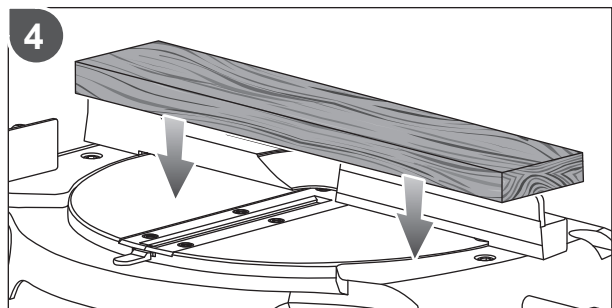
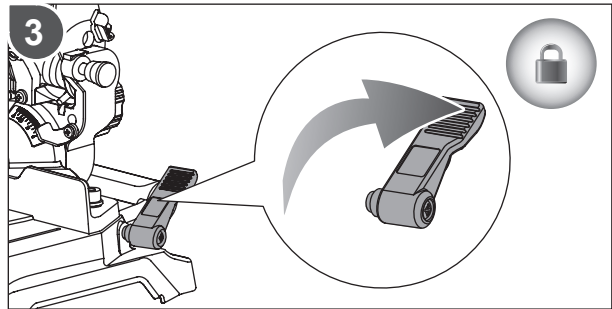
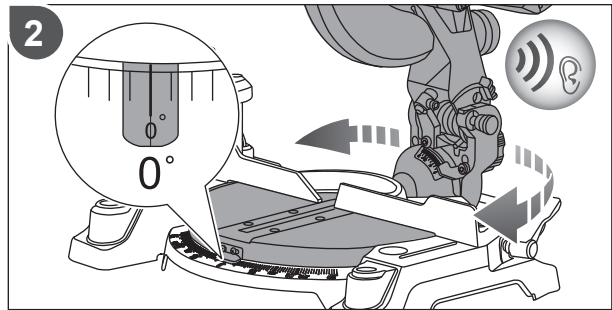
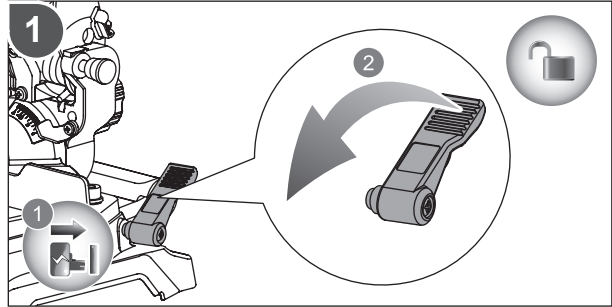
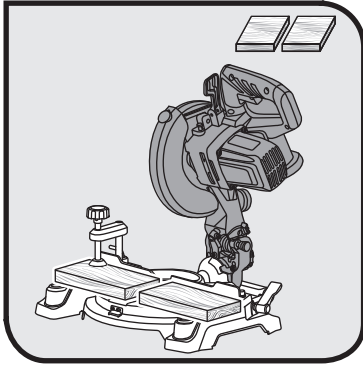



# Operation

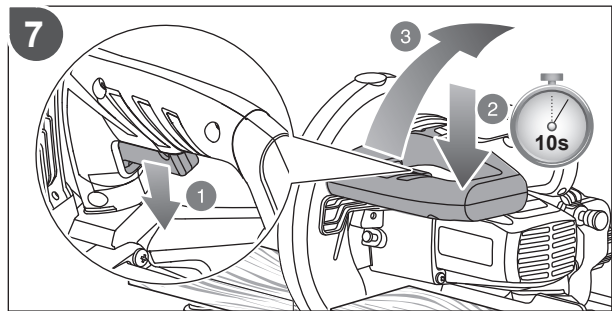
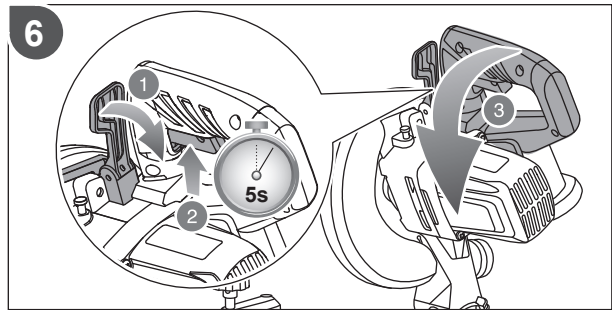
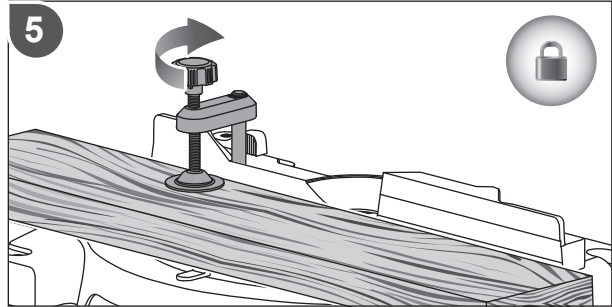



# Operation

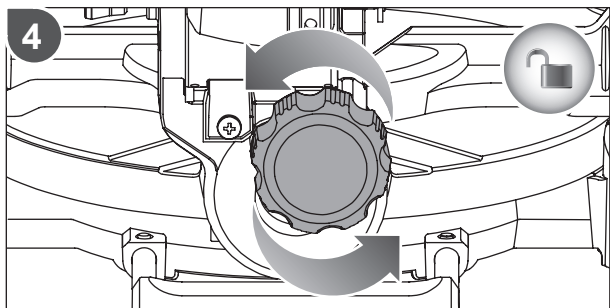
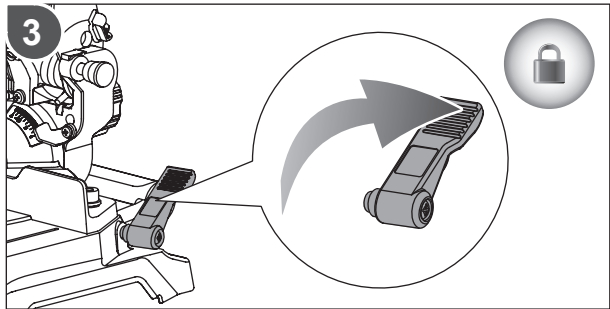
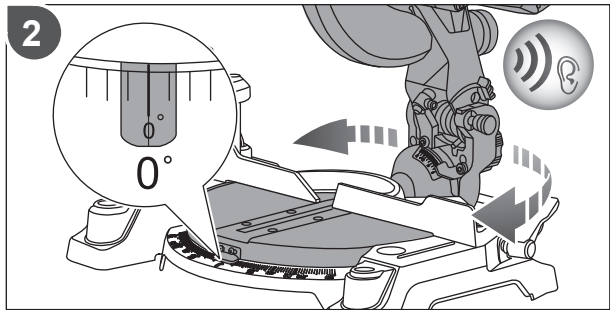
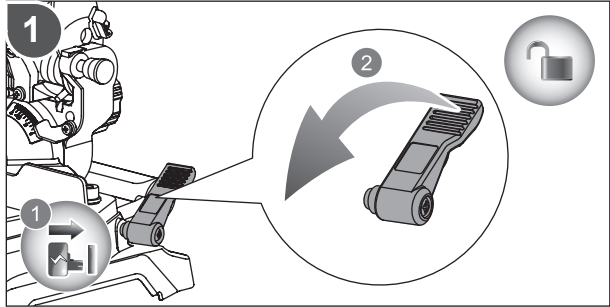
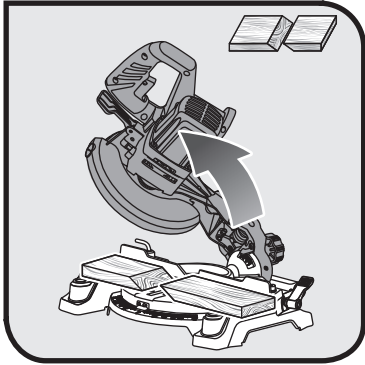



# Operation

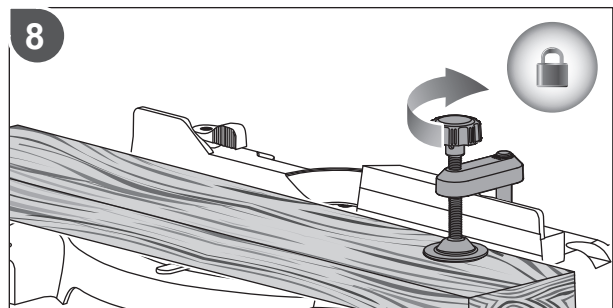
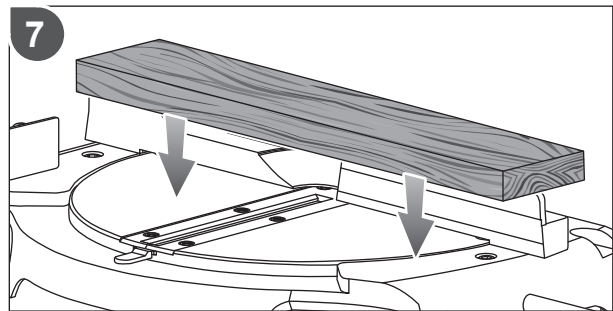
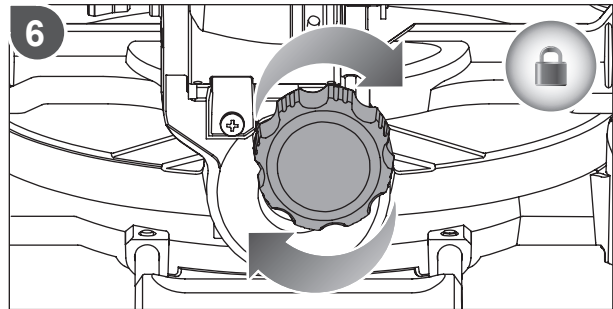
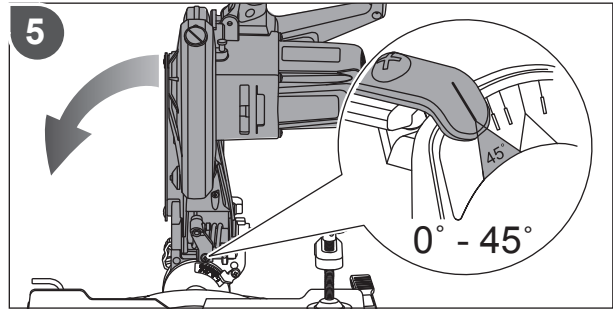



# Operation

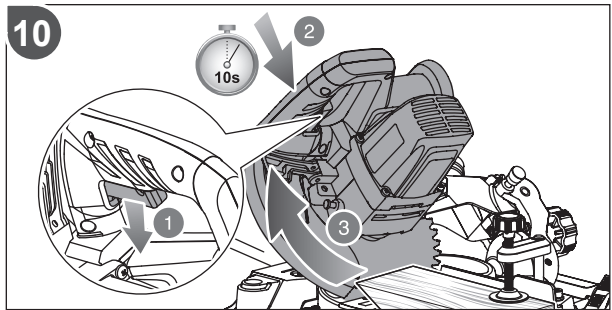
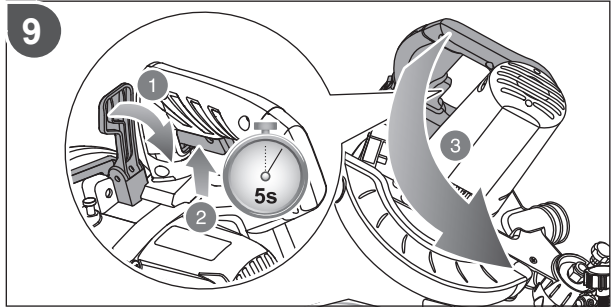



# Maintenance

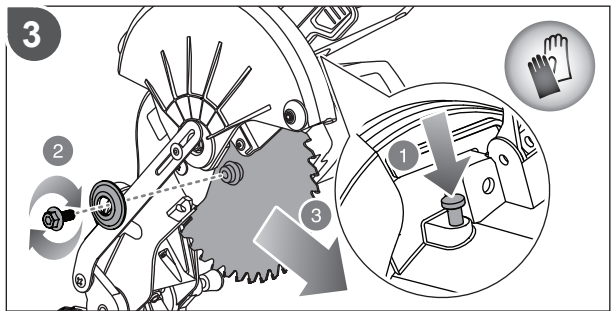
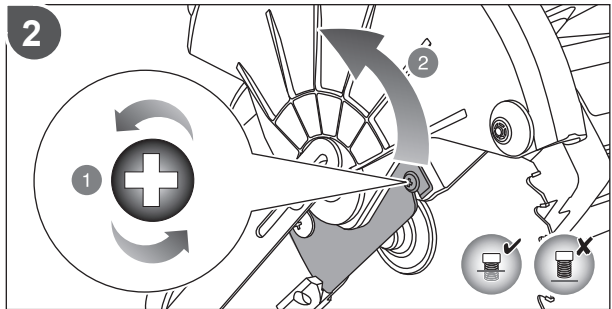
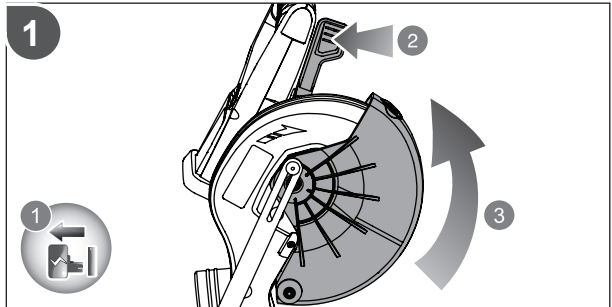
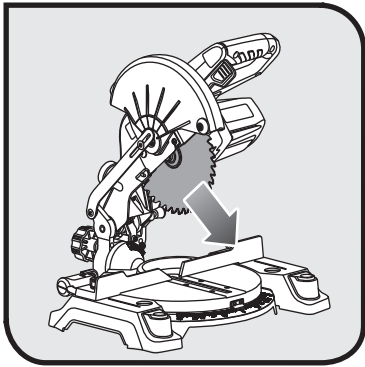



# Maintenance

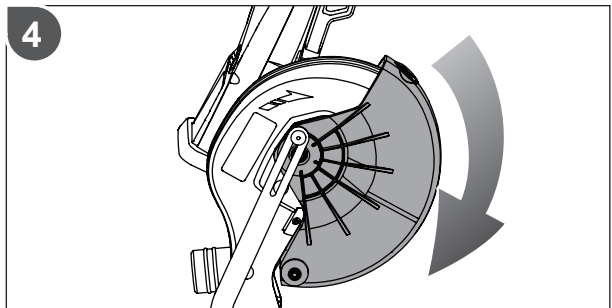
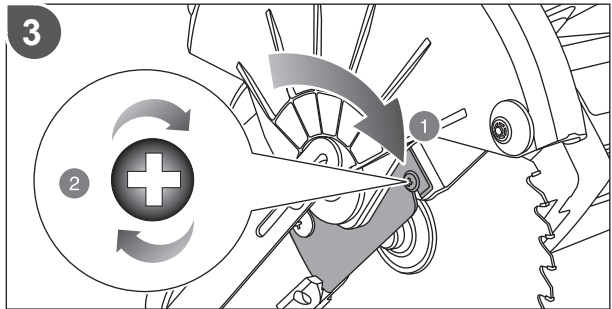
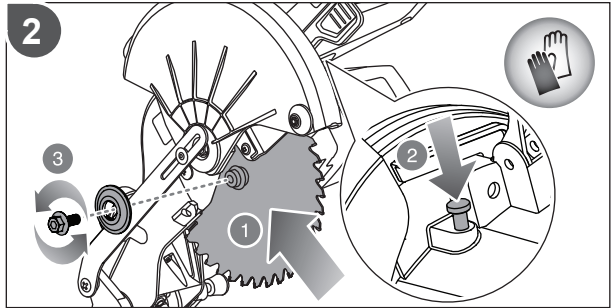
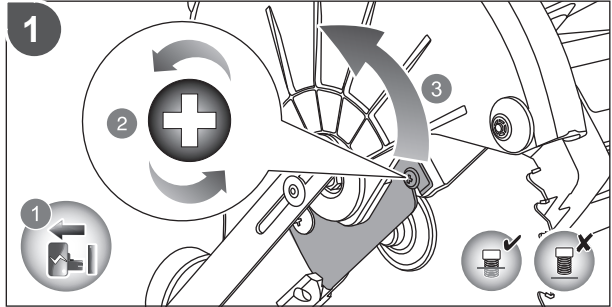
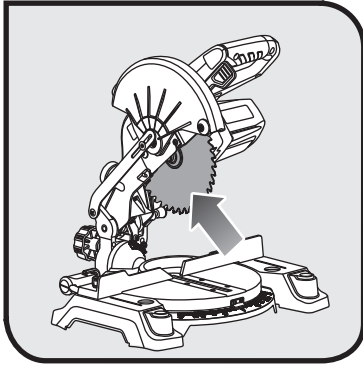



# Maintenance

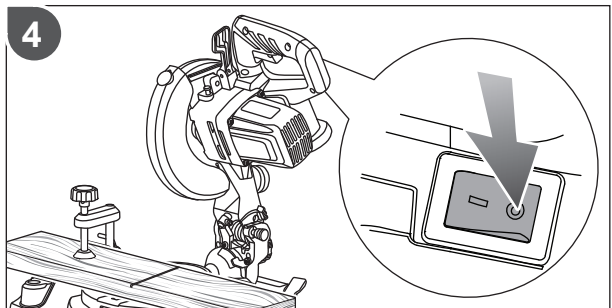
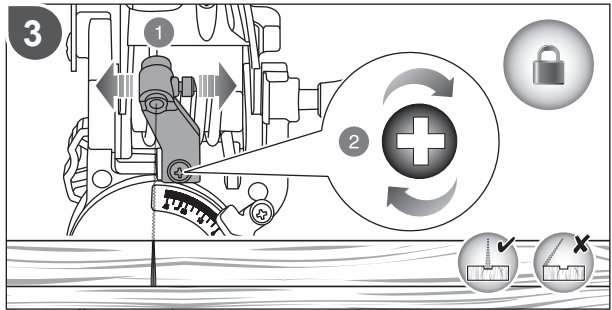
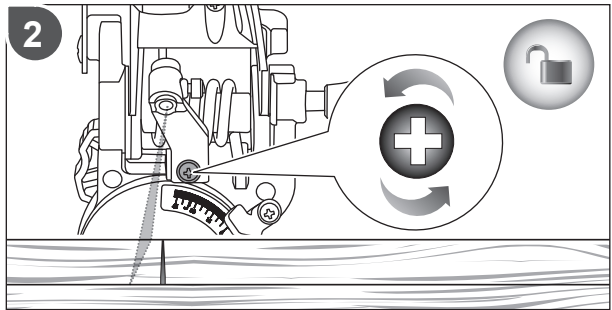
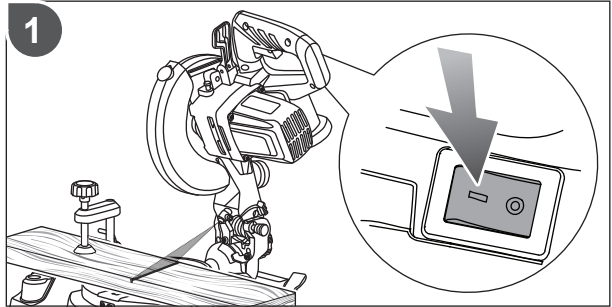
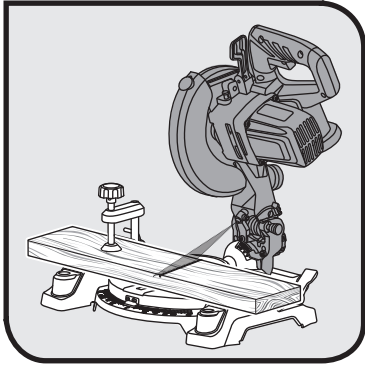





# Maintenance

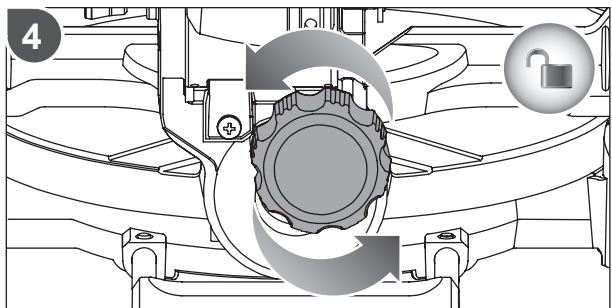
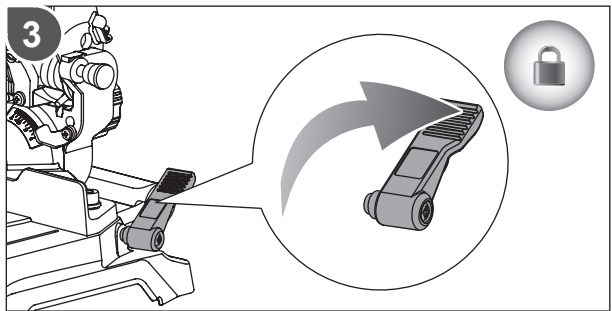
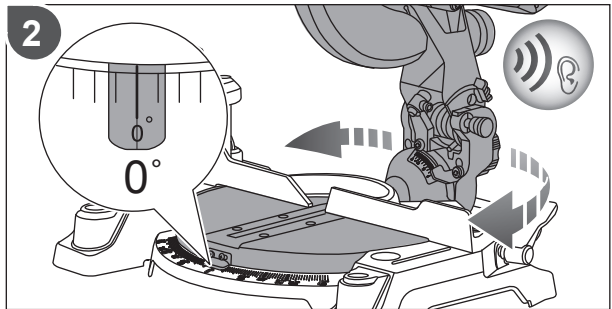
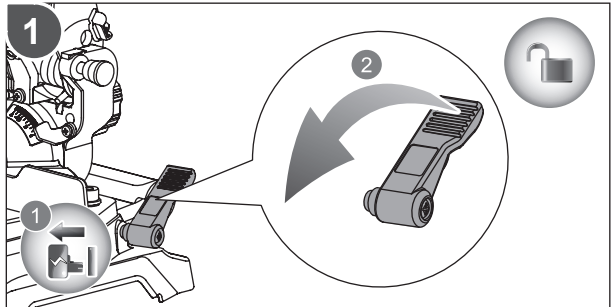
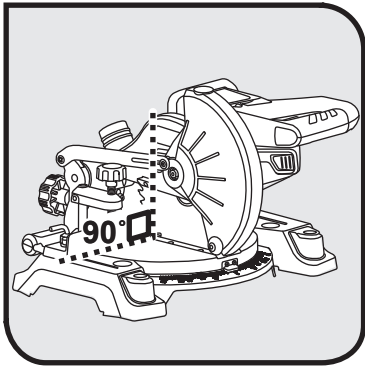



## Maintenance

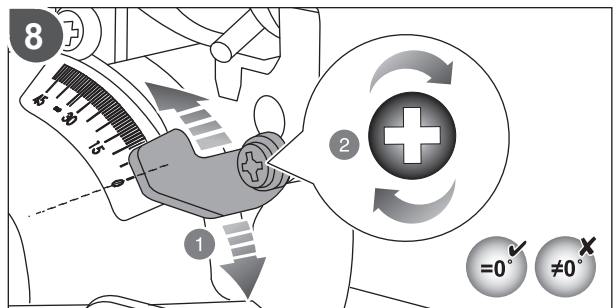
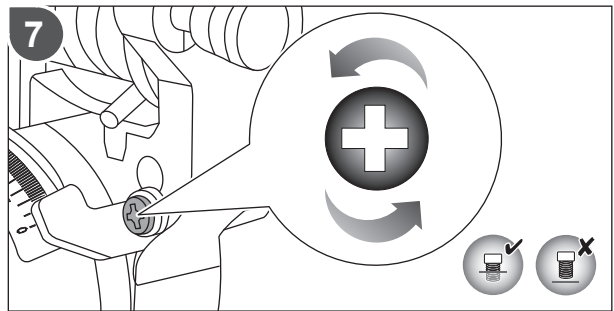
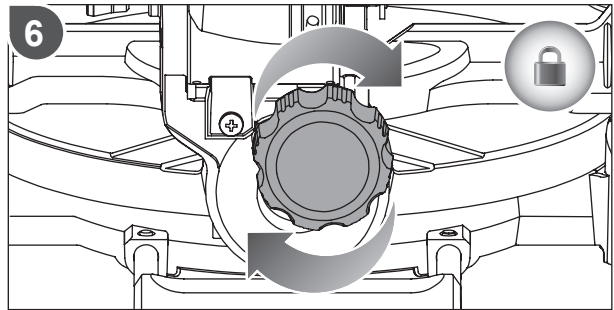
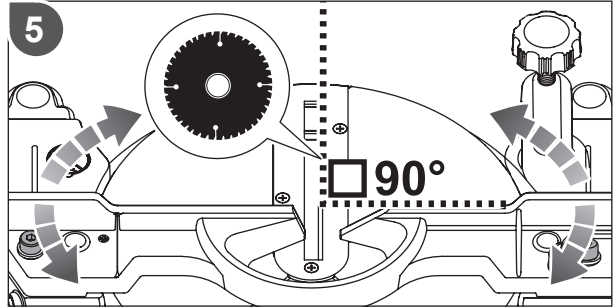



# Maintenance

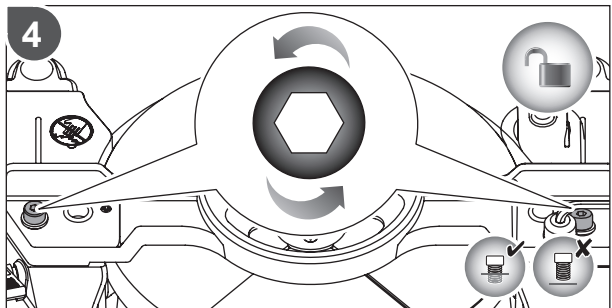
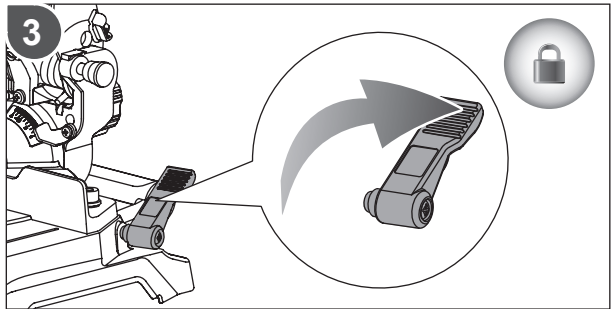
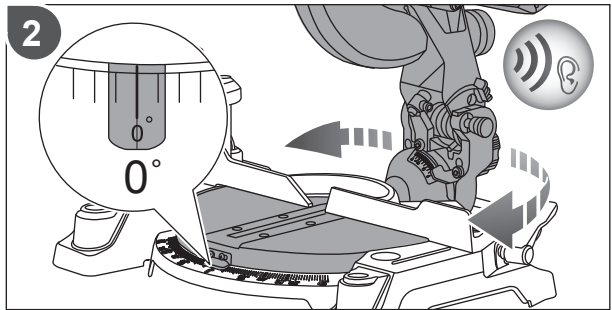
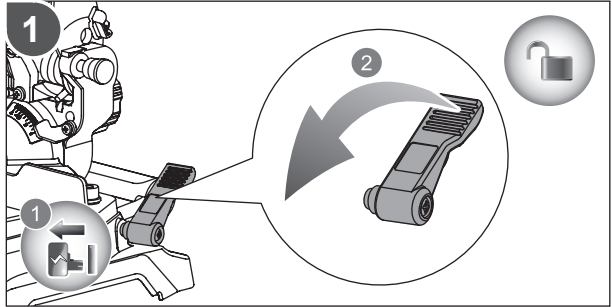
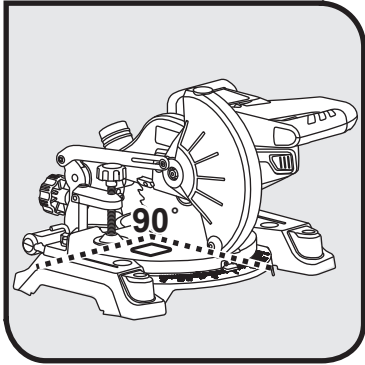



# Maintenance

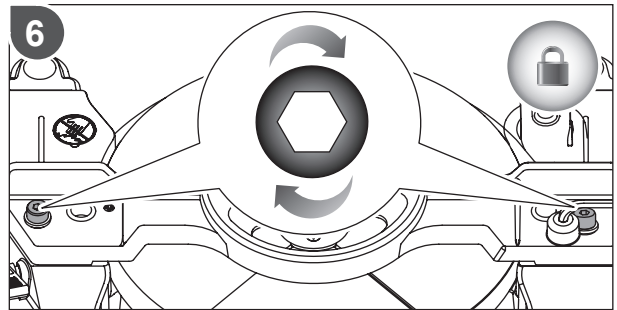
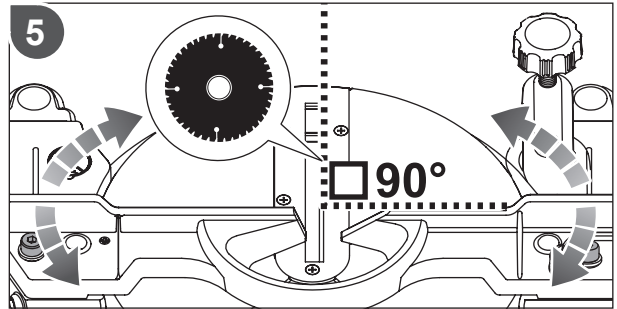



# Maintenance

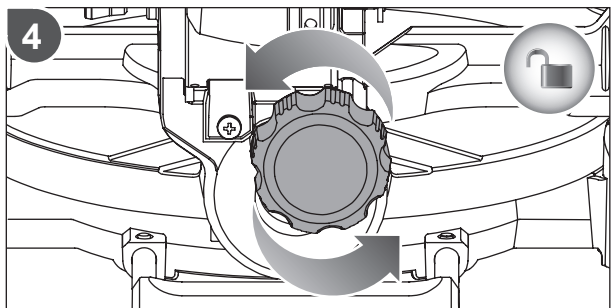
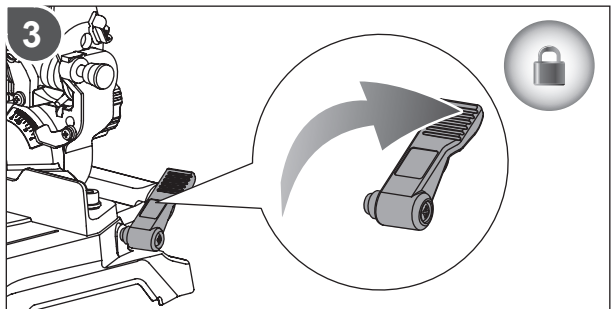
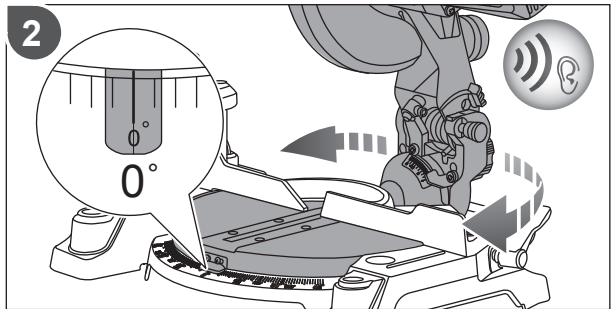
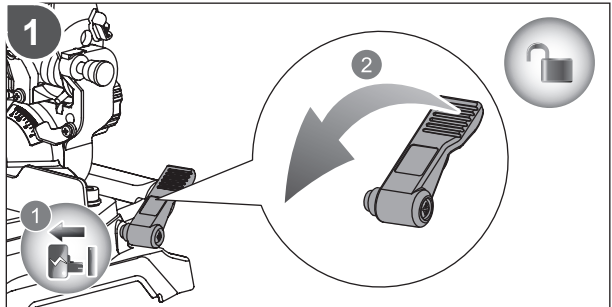
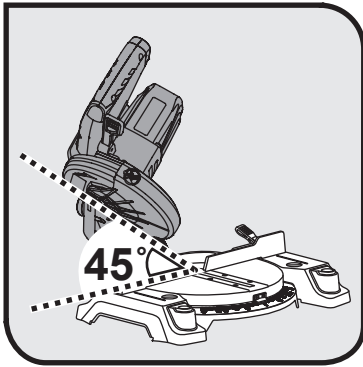



# Maintenance

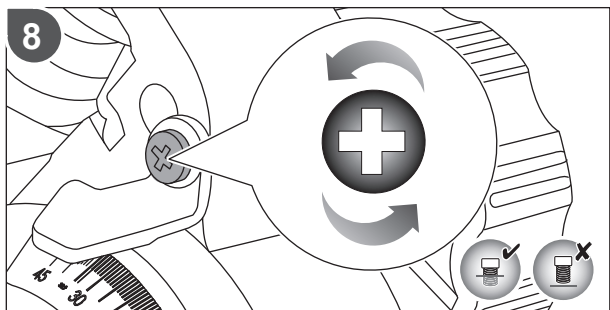
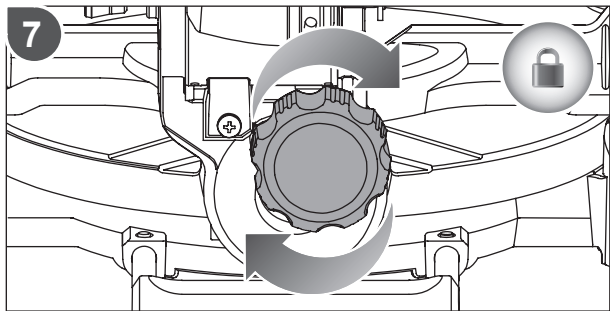
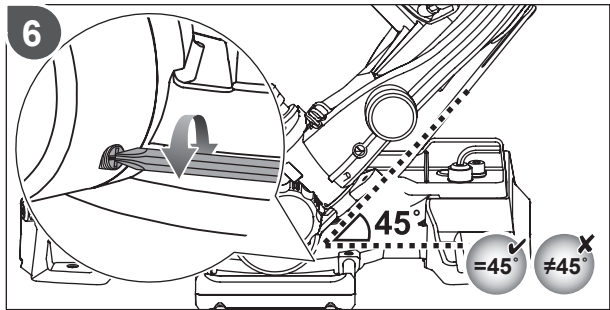
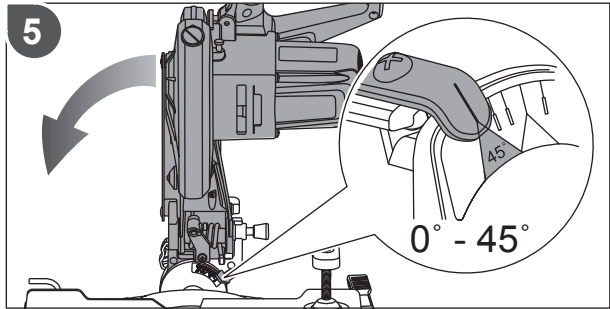



# Maintenance

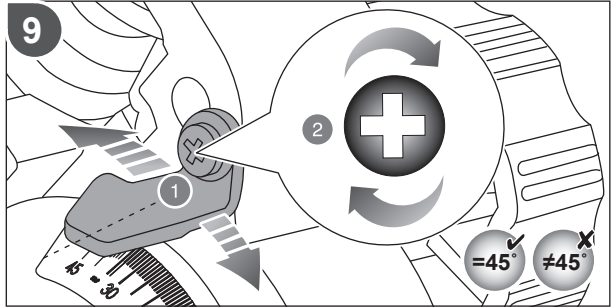



## Maintenance

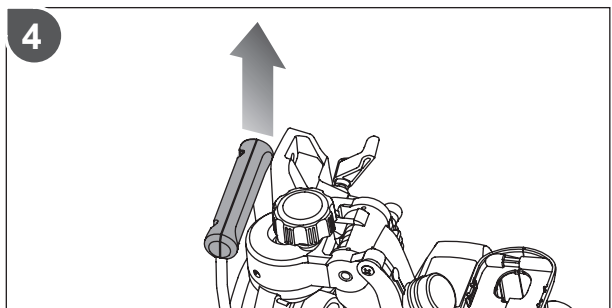
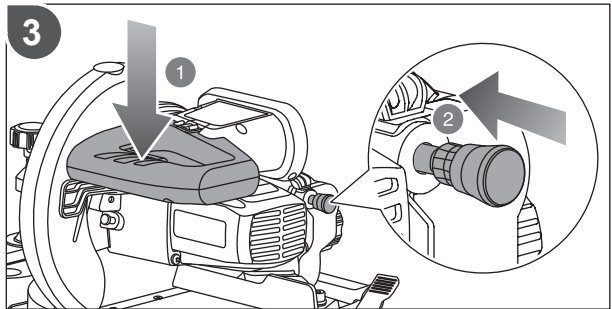
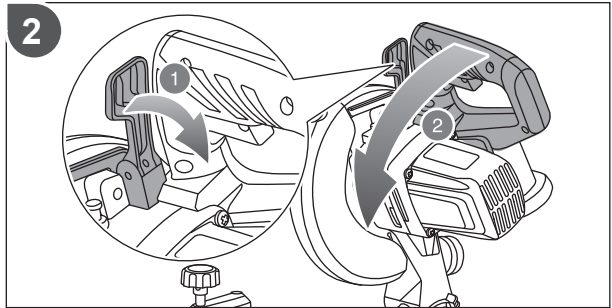
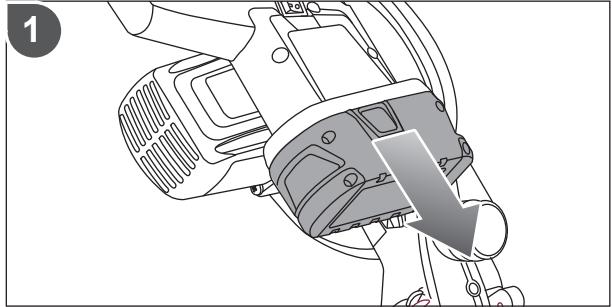
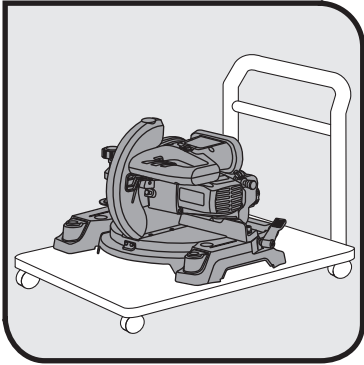



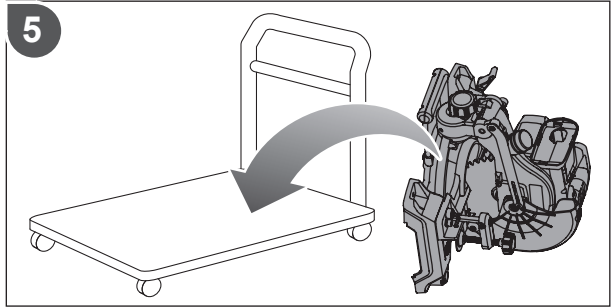

## PRODUCT SPECIFICATIONS

|                       |                         |
|-----------------------|-------------------------|
| Net weight            | 6.82 kg                 |
| Blade                 |                         |
| Diameter              | 184 mm                  |
| Thickness             | 1.8 mm                  |
| Arbor hole            | 15.88 mm                |
| Teeth                 | 24                      |
| No-load speed         | 4,500 min <sup>-1</sup> |
| Input                 | 18V                     |
| Laser safety class:   | 1M                      |
| Cutting capacity:     |                         |
| Mitre 0° / bevel 0°   | 38.1 mm x 101.95 mm     |
| Mitre 45° / bevel 0°  | 38.1 mm x 70.2 mm       |
| Mitre 0° / Bevel 45°  | 38.1 mm x 88.9 mm       |
| Mitre 45° / Bevel 45° | 30 mm x 70.2 mm         |

## BATTERY AND CHARGER

|                   | Compatible battery pack<br>(not included) | Compatible charger<br>(not included)                   |
|-------------------|---|--|
| Lithium-Ion       | BPL-1820                                  | BCL14181H<br>BCL14183H<br>BCL1418                      |
|                   | BPL-1815                                  | BCS618<br>BCL1800                                      |
| Nickel<br>Cadmium | ABP1801G<br>ABP1802G                      | BCS618<br>BCL1418<br>BCL14181H<br>BCL14183H<br>BCL1800 |





**Techtronic Industries (Australia) Pty. Ltd.**  
Level 1, 660 Doncaster Road  
Doncaster, VIC 3108, Australia

**Techtronic Industries New Zealand Ltd.**  
27 Clemow Drive  
Mt. Wellington, Auckland 1060, New Zealand