

RYOBI[®]

ORIGINAL INSTRUCTIONS

Backpack Sprayer 15L

OWS1815



Important!

It is essential that you read the instructions in this manual before assembling, operating and maintaining the product.

Subject to technical modification.

Safety, performance, and dependability have been given top priority in the design of your backpack sprayer.

INTENDED USE

The backpack sprayer is intended for outdoor use, in a well-ventilated area.

The product is designed for spraying consumer-grade home and garden chemicals such as insecticides, fungicides, weed killers, and fertilizers. The product may also be used to water plants.

Do not use the product for any purpose not listed above. The product is not to be used by children or by persons not wearing adequate personal protective equipment and clothing.

GENERAL SAFETY WARNINGS

WARNING

Read all safety warnings and all instructions. Failure to follow the warnings and instructions may result in electric shock, fire and/or serious injury.

Save all warnings and instruction for future reference.

The term "power tool" in the warnings refers to your mains-operated (corded) power tool or battery-operated (cordless) power tool.

WORK AREA SAFETY

- **Keep work area clean and well lit.** Cluttered or dark areas invite accidents.
- **Do not operate power tools in explosive atmospheres, such as in the presence of flammable liquids, gases or dust.** Power tools create sparks which may ignite the dust or fumes.
- **Keep children and bystanders away while operating a power tool.** Distractions can cause you to lose control.

ELECTRICAL SAFETY

- **Power tool plugs must match the outlet. Never modify the plug in any way. Do not use any adapter plugs with earthed (grounded) power tools.** Unmodified plugs and matching outlets will reduce risk of electric shock.
- **Avoid body contact with earthed or grounded surfaces, such as pipes, radiators, ranges and refrigerators.** There is an increased risk of electric shock if your body is earthed or grounded.
- **Do not expose power tools to rain or wet conditions.** Water entering a power tool will increase the risk of electric shock.
- **Do not abuse the cord. Never use the cord for carrying, pulling or unplugging the power tool. Keep cord away from heat, oil, sharp edges or moving parts.** Damaged or entangled cords increase the risk of electric shock.
- **When operating a power tool outdoors, use an extension cord suitable for outdoor use.** Use of a cord suitable for outdoor use reduces the risk of electric shock.

- **If operating a power tool in a damp location is unavoidable, use a residual current device (RCD) protected supply.** Use of an RCD reduces the risk of electric shock.

PERSONAL SAFETY

- **Stay alert, watch what you are doing and use common sense when operating a power tool. Do not use a power tool while you are tired or under the influence of drugs, alcohol or medication.** A moment of inattention while operating power tools may result in serious personal injury.
- **Use personal protective equipment. Always wear eye protection.** Protective equipment such as dust mask, non-skid safety shoes, hard hat, or hearing protection used for appropriate conditions will reduce personal injury.
- **Prevent unintentional starting. Ensure the switch is in the off-position before connecting to power source and/or battery pack, picking up or carrying the tool.** Carrying power tools with your finger on the switch or energising power tools that have the switch on invites accidents.
- **Remove any adjusting key or wrench before turning the power tool on.** A wrench or a key left attached to a rotating part of the power tool may result in personal injury.
- **Do not overreach. Keep proper footing and balance at all times.** This enables better control of the power in unexpected situations.
- **Dress properly. Do not wear loose clothing or jewellery. Keep your hair, clothing and gloves away from moving parts.** Loose clothes, jewellery or long hair can be caught in moving parts.
- **If devices are provided for the connection of dust extraction and collection facilities, ensure these are connected and properly used.** Use of dust collection can reduce dust-related hazards.
- **Do not let familiarity gained from frequent use of tools allow you to become complacent and ignore tool safety principles.** A careless action can cause severe injury within a fraction of a second.

POWER TOOL USE AND CARE

- **Do not force the power tool. Use the correct power tool for your application.** The correct power tool will do the job better and safer at the rate for which it was designed.
- **Do not use the power tool if the switch does not turn it on and off.** Any power tool that cannot be controlled with switch is dangerous and must be repaired.
- **Disconnect the plug from the power source and/or the battery pack from the power tool before making any adjustments, changing accessories, or storing power tools.** Such preventive safety measures reduce the risk of starting the power tool accidentally.
- **Store idle power tools out of the reach of children and do not allow persons unfamiliar with the power tool or these instructions to operate the power tool.** Power tools are dangerous in the hands of untrained users.
- **Maintain power tools. Check for misalignment or binding of moving parts, breakage of parts and any**

other condition that may affect the power tool's operation. If damaged, have the power tool repaired before use. Many accidents are caused by poorly maintained power tools.

- **Keep cutting tools sharp and clean.** Properly maintained cutting tools with sharp cutting edges are less likely to bind and are easier to control.
- **Use the power tool, accessories and tool bits etc. in accordance with these instructions, taking into account the working conditions and the work to be performed.** Use of the power tool for operations different from those intended could result in a hazardous situation.
- **Keep handles and grasping surfaces dry, clean and free from oil and grease.** Slippery handles and grasping surfaces do not allow for safe handling and control of the tool in unexpected situations.

BATTERY TOOL USE AND CARE

- **Recharge only with the charger specified by the manufacturer.** A charger that is suitable for one type of battery pack may create a risk of fire when used with another battery pack.
- **Use power tools only with specifically designated battery packs.** Use of any other battery packs may create a risk of injury and fire.
- **When battery pack is not in use, keep it away from other metal objects, like paper clips, coins, keys, nails, screws or other small metal objects, that can make a connection from one terminal to another.** Shorting the battery terminals together may cause burns or a fire.
- **Under abusive conditions, liquid may be ejected from the battery; avoid contact. If contact accidentally occurs, flush with water. If liquid contacts eyes, additionally seek medical help.** Liquid ejected from the battery may cause irritation or burns.
- **Do not use a battery pack or tool that is damaged or modified.** Damaged or modified batteries may exhibit unpredictable behaviour resulting in fire, explosion or risk of injury.
- **Do not expose a battery pack or tool to fire or excessive temperature.** Exposure to fire or temperature above 130°C may cause explosion.
NOTE: The temperature 130°C can be replaced by the temperature 265°F.
- **Follow all charging instructions and do not charge the battery pack or tool outside the temperature range specified in the instructions.** Charging improperly or at temperatures outside the specified range may damage the battery and increase the risk of fire.

SERVICE

- **Have your power tool serviced by a qualified repair person using only identical replacement parts.** This will ensure that safety of the power tool is maintained.
- **Never service damaged battery packs.** Service of battery packs should only be performed by the manufacturer or authorized service providers.

BACKPACK SPRAYER SPECIFIC SAFETY WARNINGS

- Do not spray flammable liquids, such as gasoline, to reduce the risk of fire or explosion.
- The sprayer shall be used only with plant protection products approved by local/national regulatory authorities for plant protection products for use with knapsack sprayers. Always follow the chemical manufacturer's instructions printed on their product labeling for use, cleaning, and storage. Chemicals should be stored out of the reach of children.
- Do not spray any material where the hazard is not known.
- To reduce exposure to spray materials, wear approved safety equipment, such as face mask designed for spraying, gloves, and other appropriate protective equipment.
- Do not use flammable solvents or abrasive cleaning agents to clean the product.

⚠ WARNING

Keep spray materials away from eyes. If spray materials come in contact with the eyes, wash them immediately with clean water. If irritation is still present, immediately seek medical help.

ADDITIONAL SAFETY WARNINGS

- Never allow children, persons with reduced physical, sensory, or mental capabilities or lack of experience and knowledge, or people unfamiliar with these instructions to use the product.
- Be aware of any hazards presented by the spray materials. Before using any pesticide or other spray materials with the product, carefully read the label on the original container and follow the instructions.
- Keep the area clear of all bystanders, children, and pets while spraying.
- It is strongly suggested that you have adequate training in the safety and use of this tool.
- Remember to properly replace and tighten the spray tank cover after pouring liquid into the spray tank.
- Use only consumer-grade water-based lawn and garden chemicals.
- Do not use commercial-grade chemicals or chemicals for commercial or industrial purposes.
- Do not use caustic (alkali) self-heating or corrosive (acid) liquids with the product. These can corrode metal parts or weaken the tank and hose.
- Do not leave residue or spray material in the spray tank after using the product. Clean the spray tank after each use.
- Do not pour hot or boiling liquids into the spray tank. These can weaken or damage the hose or spray tank.
- Do not overfill the tank.
- Always check for leaks. If any are found, correct them before using the product.
- The spray area must be well-ventilated.

- Always inspect both the inside and outside of the product before each use.
- Liquids to be sprayed must be as thin as water. Thicker liquids will not spray properly.
- Spray materials may be premixed and poured into the spray tank using a funnel, if necessary.
- Wear proper protective clothing and equipment when using, filling, and cleaning the sprayer. Follow the chemical manufacturer's instructions with respect to protective equipment.
- Immediately change work clothes contaminated with plant control chemicals.
- Wear full eye protection while operating the product. If you are spraying overhead, wear impermeable head covering.
- Do not use the product when you are tired, ill, or under the influence of alcohol, drugs, or medication.

NOTE: When using a measuring container other than the measuring cup, or when using a funnel to fill the tank, thoroughly clean and rinse these items after use. When premixing spray materials, rinse the container used for mixing.

- Do not spray where spark, flame, or other source of ignition is present.
- Do not spray in the direction of people or animals. Always spray downwind.
- Do not smoke, eat, or drink while using the product.
- Do not discharge directly against skin.
- Do not let the spray materials come in contact with skin. If contact does occur, wash immediately with soap and plenty of water.
- Aim the nozzle directly at the plants or objects you intend to spray.
- Ensure that the spray materials are directed at an area that will not be damaged by the spray materials.
- Avoid spraying on windy days. The spray materials can be accidentally blown onto plants or objects that should not be sprayed.
- Keep spray materials away from eyes. If spray materials come in contact with the eyes, wash them immediately with clean water. If irritation is still present, immediately seek medical help.
- Electric shock hazard. Do not spray towards electrical outlets.
- Immediately turn off and remove the battery pack in the event of accident or breakdown. Don't operate the product again until it has been fully checked by an authorised service centre.
- If there is no spray coming out from the nozzle or the spray amount decreased, the hose and wand system may be blocked. Rinse and clean all parts of the hose and wand system (spray gun, filter in tank, spray wand, hose) with clean water.
- After long time storage or after winter, spray the backpack sprayer with clean water. Check if there is any leakage or crack.
- Maintain the product. Thoroughly inspect both the inside and outside of the product and examine the

components before each use. Check for cracked and deteriorated hoses, leaks, clogged nozzles, and missing or damaged parts. If damaged, have the product repaired before use. Many accidents are caused by poorly maintained products.

- Remove the battery from the product before draining, cleaning, or storing to avoid accidental starting.

MIXING THE SPRAY SOLUTION

WARNING

Mix the chemicals strictly in accordance with the manufacturer's instructions. Incorrect mixtures may produce toxic fumes or explosive solutions.

- Never spray liquid plant control chemicals undiluted.
- Prepare solution and fill the container outdoors only or in well-ventilated locations.
- Prepare only sufficient solution for the job at hand so that nothing is left over.
- Do not mix different chemicals unless such mixture is approved by the manufacturer.

FILLING THE CONTAINER

- Stand the sprayer on a level surface, do not fill the container above the maximum mark.
- When filling from the central water supply, do not immerse the end of the hose in the solution. Sudden low pressure in the system may cause the solution to be sucked back into the water supply.
- Before filling the container with spray solution, carry out a test run with fresh water, and check all parts of the sprayer for leaks.
- After filling, fit the filler cap, and tighten it down firmly.
- Hang a tag to the product to note what chemical is being used.

APPLICATION

- Work only in the open or in well-ventilated locations, e.g. open greenhouses.
- Never blow through nozzles or other components by mouth.
- Avoid contact with plant control chemicals, immediately change clothing contaminated with plant control chemicals.
- Do not spray in windy conditions.
- Too high or too low pressure or unfavorable weather conditions can result in the wrong solution concentration. Overdosing may damage plants and the environment. Underdosing may result in unsuccessful plant treatment.
- To reduce the risk of damage to the environment and plants, do not operate the sprayer:
 - when pressure is too high or too low
 - in windy conditions
 - in direct sunlight
- To reduce the risk of accidents and damage to the sprayer, never operate the sprayer with:
 - flammable liquids

- viscous or sticky liquids
- caustic or corrosive chemicals
- liquids hotter than 50°C
- Avoid using the product in freezing weather since the solution may freeze.

ADDITIONAL BATTERY SAFETY WARNINGS

WARNING

To reduce the risk of fire, personal injury, and product damage due to a short circuit, never immerse your tool, battery pack or charger in fluid or allow a fluid to flow inside them. Corrosive or conductive fluids, such as seawater, certain industrial chemicals, and bleach or bleach-containing products, etc., can cause a short circuit.

TRANSPORTATION AND STORAGE

- Remove the battery pack.
- Ensure that all parts are clean and dry.
- Clean all foreign materials from the product.
- Drain all spray materials from the spray tank before storage.
- After each use, check all parts of the product for leaks. Return the product to an authorised service center for repair, if it has any.
- The nozzle wand can be stored in the tank lid and the frame side.
- For transportation, secure the product against movement or falling to prevent injury to persons or damage to the product.
- Store the product in a cool, dry and well-ventilated place that is inaccessible to children. Keep away from corrosive agents such as garden chemicals and de-icing salts. Do not store the product outdoors.

TRANSPORTING LITHIUM BATTERIES

Transport the battery in accordance with local and national provisions and regulations.

Follow all special requirements on packaging and labeling when transporting batteries by a third party. Ensure that no batteries can come in contact with other batteries or conductive materials while in transport by protecting exposed connectors with insulating, non-conductive caps or tape. Do not transport batteries that are cracked or leaking. Check with the forwarding company for further advice.

MAINTENANCE

Avoid using solvents when cleaning plastic parts. Most plastics are susceptible to damage from various types of commercial solvents and may be damaged by their use. Use clean cloths to remove dirt, dust, oil, or grease.

CAUTION

Do not at any time let brake fluids, gasoline, petroleum-based products, or penetrating oils, come in contact with plastic parts. Chemicals can damage, weaken or destroy plastic which may result in serious personal injury.

WARNING

Use only original manufacturer's replacement parts, accessories and attachments. Failure to do so can cause possible injury, poor performance and may void your warranty.

WARNING

Servicing requires extreme care and knowledge and should be performed only by a qualified service technician. Have the product serviced by an authorised service centre only. When servicing, use only identical replacement parts.

WARNING

To avoid serious personal injury, always remove the battery pack from the product when cleaning or performing any maintenance.

- Only make adjustments or repairs described in this manual. For other repairs, contact an authorised service centre.
- After each use, clean the product as prescribed in this manual.
- Drain and empty the spray tank before cleaning.
- Drain the spray materials through the fill area.
- **NOTE:** Drain all of the spray materials from the spray tank into a container approved for chemicals. Do not store chemicals in the spray tank.
- Use clean water to clean and rinse the spray tank. A small amount of mild household detergent may be added.
- Wipe the product with a clean, dry cloth.
- It may be necessary to rinse the spray tank more than once.

DISPOSAL

Never dispose residual chemicals or contaminated rinsing solutions in waterways, drains, sewers, street gutters, or manholes.

Dispose residual chemicals and used containers in accordance with local waste disposal regulations.

RESIDUAL RISKS

Even when the product is used as prescribed, it is still impossible to completely eliminate certain residual risk factors. The following hazards may arise and the operator should pay special attention to avoid the following:

- Electric shock. Never spray liquid towards electrical sockets, cables, or appliances.
- Contact with hazardous substances. Spray materials may be harmful if inhaled, ingested, or comes in contact

with skin or eyes. Follow instructions carefully and wear appropriate protective equipment as prescribed in this manual.

⚠ WARNING

Injuries may be caused or aggravated by prolonged use of a tool. When using any tool for prolonged periods, ensure you take regular breaks.

WHAT'S IN THE BOX

See page 6

- Backpack sprayer x1
- Nozzle wand x1
- Flat fan nozzle x1
- Cone spray nozzle x1
- Elbow x1
- Operator's manual x1

SYMBOLS ON THE PRODUCT



Safety alert



Read and understand all instructions before operating the product, follow all warnings and safety instructions.



Wear eye protection.



Wear a mask.



Wear non-slip, liquid-resistant gloves.



Wear non-slip safety footwear when using the product.



Wear safety clothing.



Keep bystanders, especially children and animals away from the work area. Never spray in the direction of bystanders.



Do not expose to rain or damp condition..



Regulatory Compliance Mark (RCM). Product meets applicable regulatory requirements.



Waste electrical products should not be disposed of with household waste. Please recycle where facilities exist. Check with your local authority or retailer for recycling advice.

SYMBOLS IN THIS MANUAL



Stop the product.



Lock



Unlock



Parts or accessories sold separately



Note



Warning

The following signal words and meanings are intended to explain the levels of risk associated with the product:

⚠ DANGER

Indicates an imminently hazardous situation, which, if not avoided, will result in death or serious injury.

⚠ WARNING

Indicates a potentially hazardous situation, which, if not avoided, could result in death or serious injury.

⚠ CAUTION

Indicates a potentially hazardous situation, which, if not avoided, may result in minor or moderate injury.

CAUTION

Without safety alert symbol

Indicates a situation that may result in property damage.

WHAT'S IN THE BOX

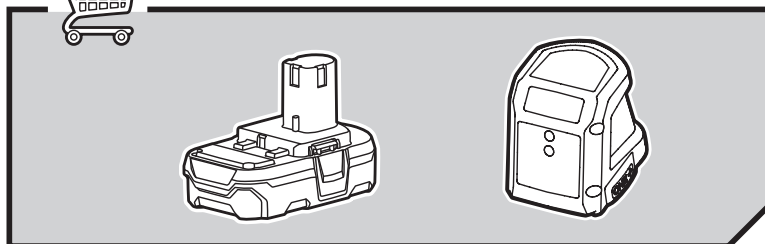
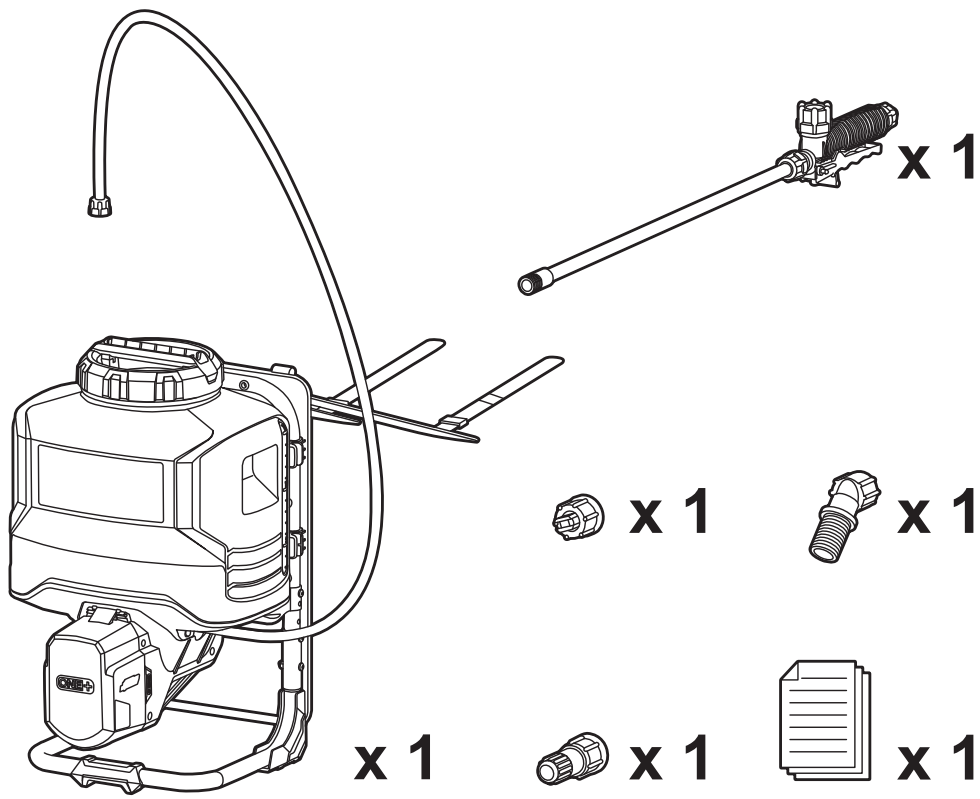

KNOW YOUR PRODUCT

1. Tank lid
2. Basket filter
3. Trigger
4. Handle cap
5. Lock-on latch
6. Wand
7. Hose
8. Elbow
9. Flat fan nozzle
10. Cone spray nozzle
11. Battery cover
12. ON/OFF switch
13. Pick-up tube
14. Plastic filter

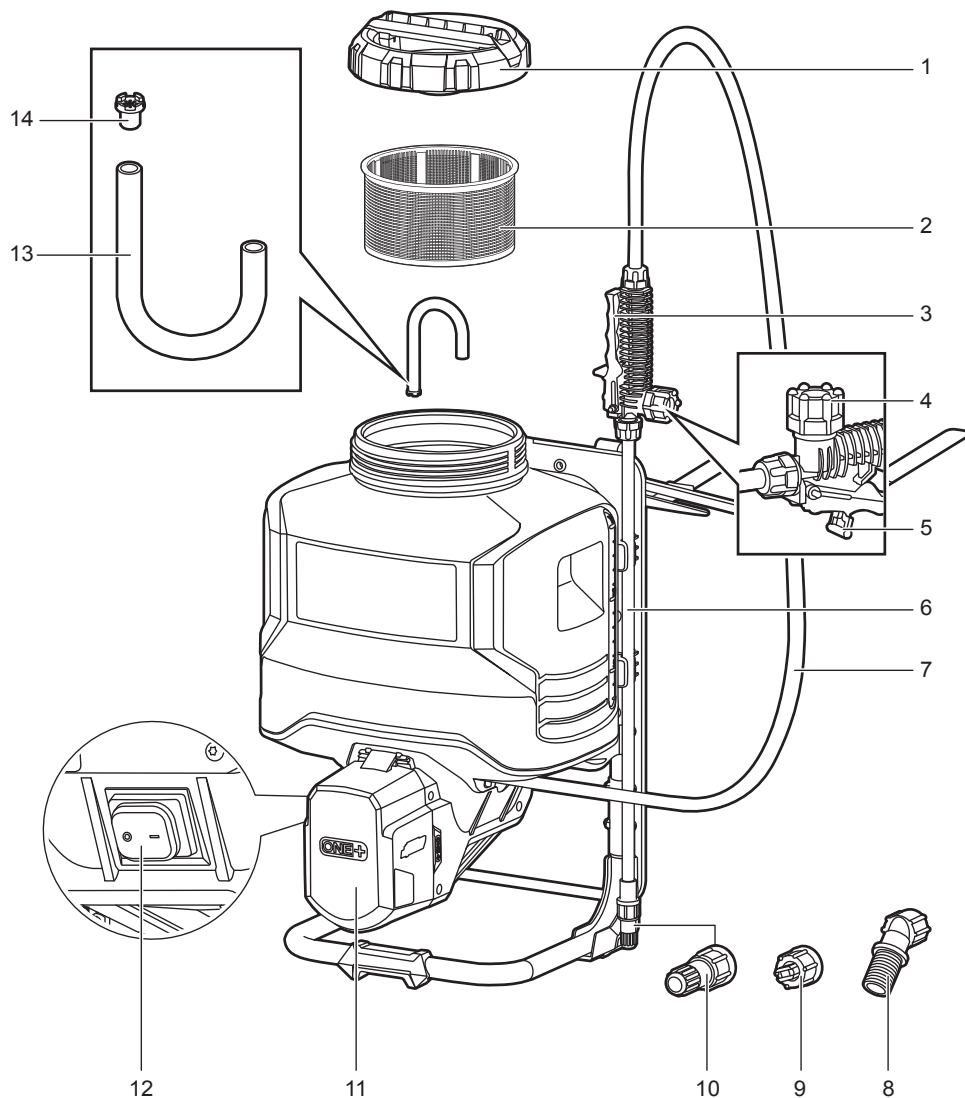

GETTING STARTED

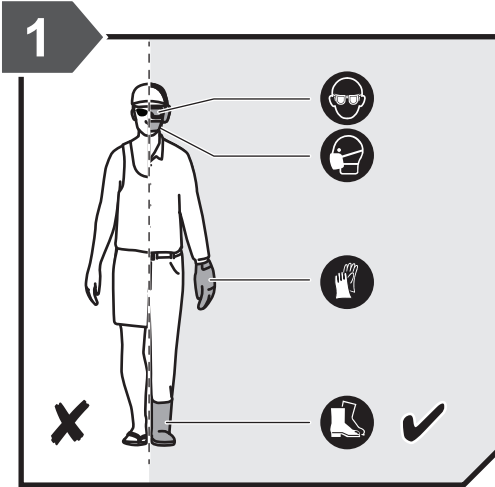

Always wear safety goggles or safety glasses with side shields when operating the product. Wear non-skid, protective footwear that will protect your feet and improve your footing on slippery surfaces.

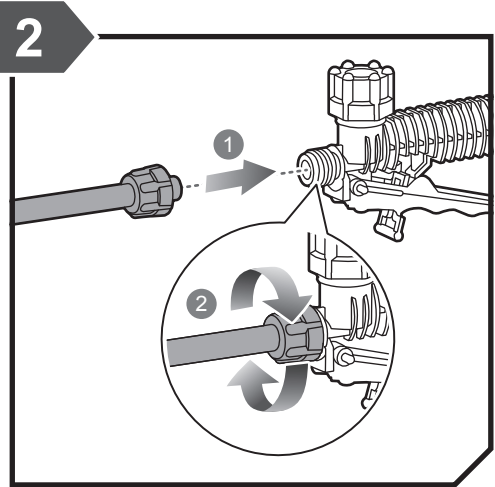

Insert the spray wand into the trigger handle. Slide the nut onto the threaded coupling and hand tighten securely.

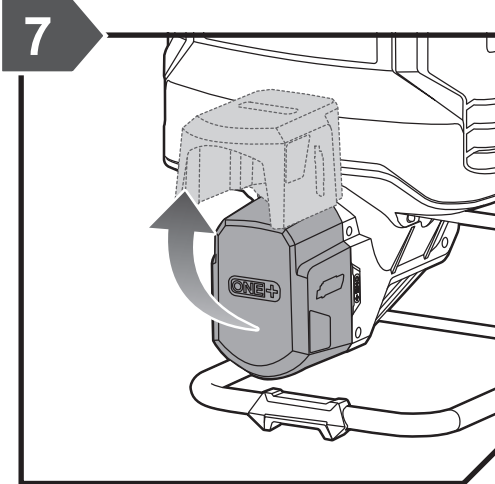

Raise the battery cover.

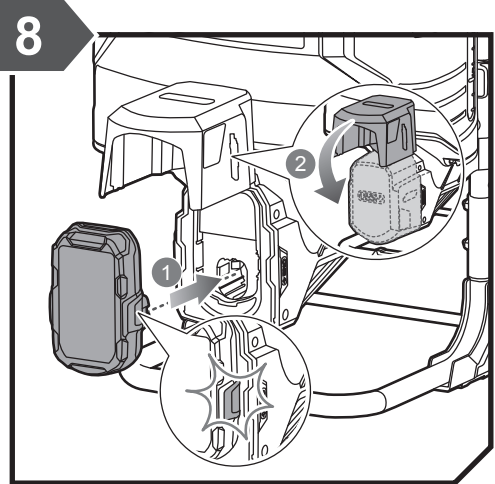

Align the raised rib on the battery pack with the groove in the battery port and place the battery pack in the tool.

Make sure the latches on each side of the battery pack snap in place and that the battery pack is secured in the tool before beginning operation. Lower the battery cover.

GETTING STARTED

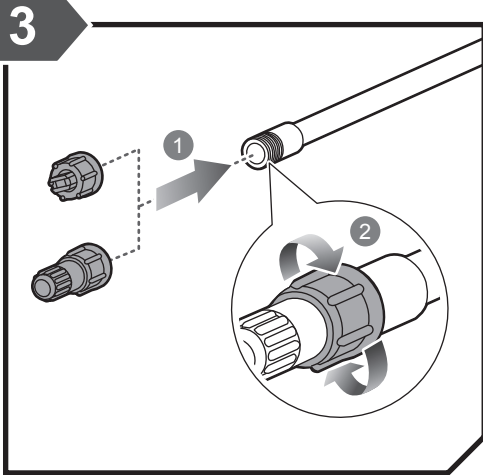

Install either the flat fan nozzle or cone spray nozzle and tighten.

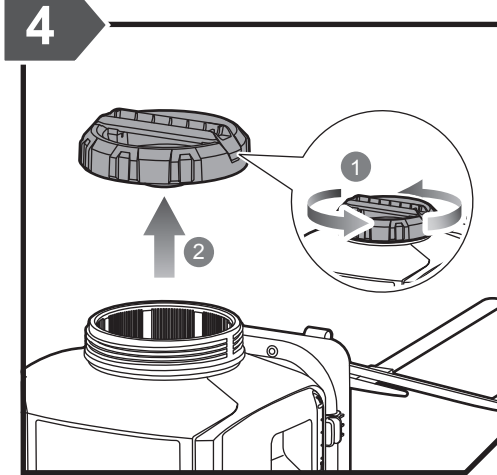

Untighten the tank lid and remove it from the tank.

GETTING STARTED

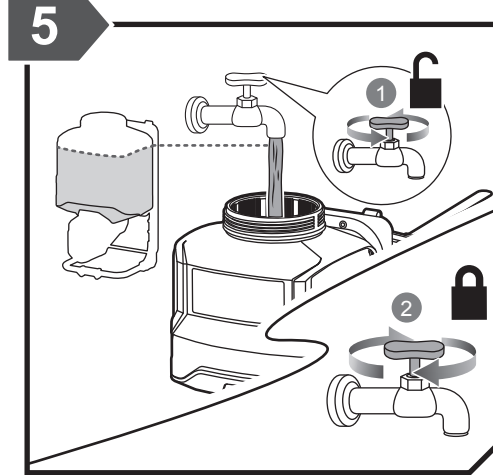

Fill the tank with the desired amount of liquid (up to 15L).

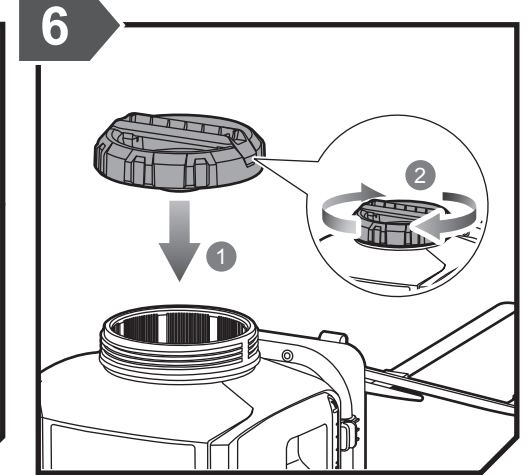

Place the tank lid back onto the tank and tighten.

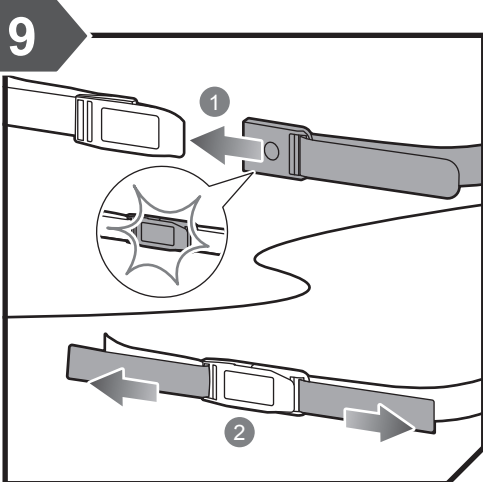

Insert the harness buckle to the harness latch. Pull both ends of the harness to tighten.

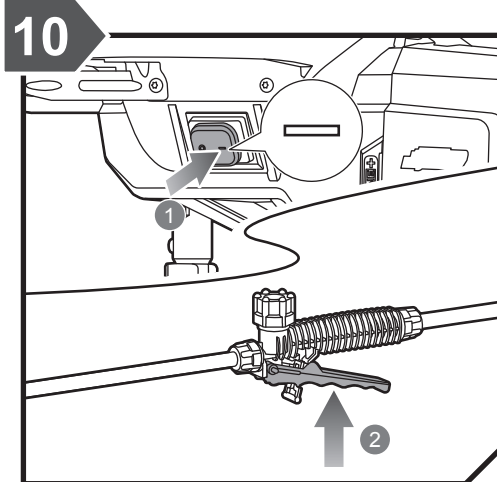

Turn on the product. To start the flow of liquid at the spray wand, squeeze the trigger.

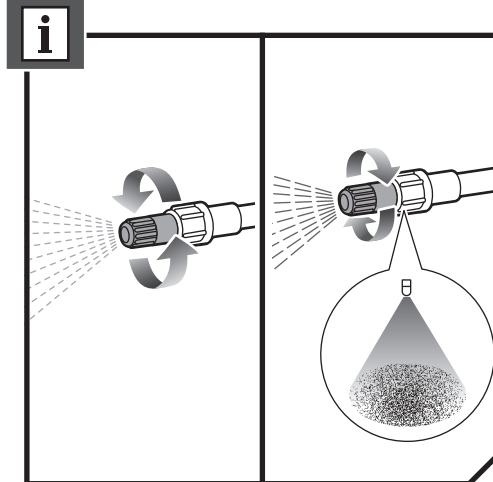

The cone spray nozzle adjusts the flow of liquid from a stream to a cone spray.

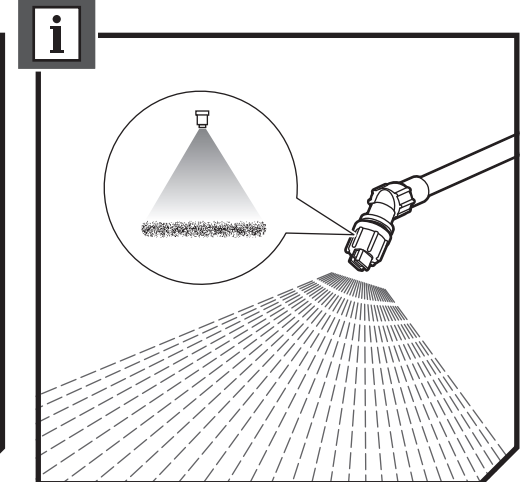

The flat nozzle provides a fan spray.



OVERVIEW

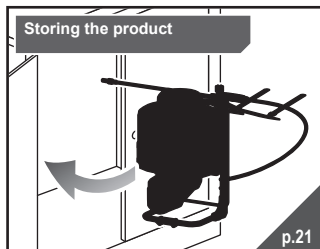
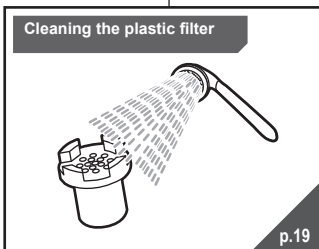
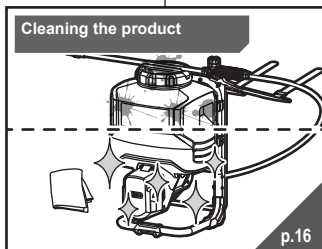
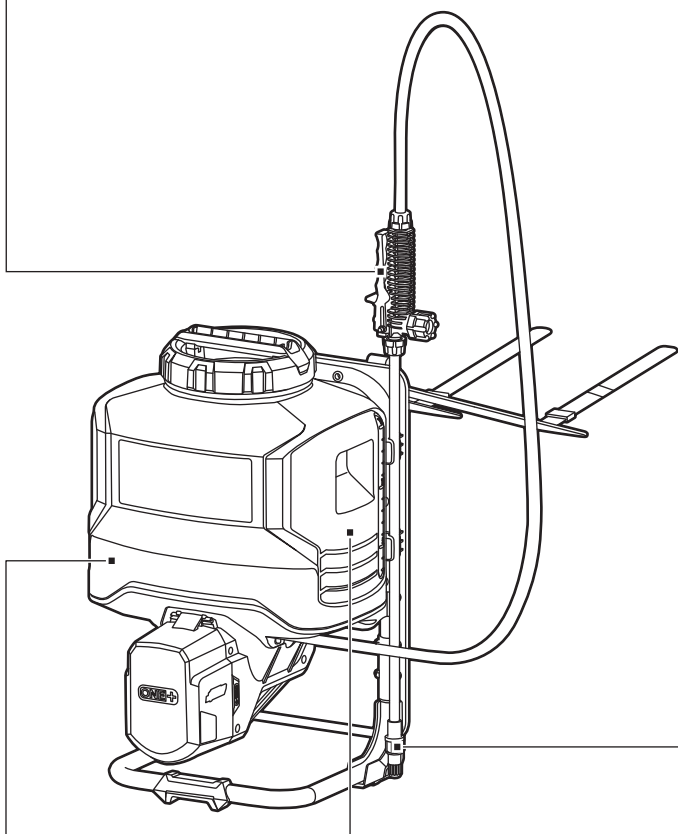
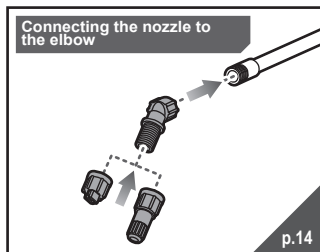
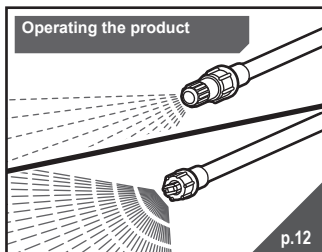

OPERATION

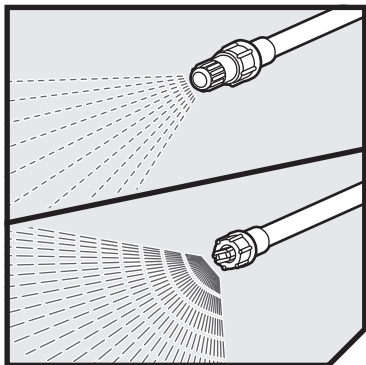

OPERATING THE PRODUCT

WARNING: Do not smoke, eat, or drink while using the product. Do not spray in the direction of people or animals. Always spray downwind.

1. Install the battery pack.
 - Raise the battery cover.
 - Place the battery pack into the product. Make sure the latches on each side of the battery pack snap in place.
 - Lower the battery cover.
2. Turn on the product.
3. To start the flow of liquid at the spray wand, squeeze the trigger.

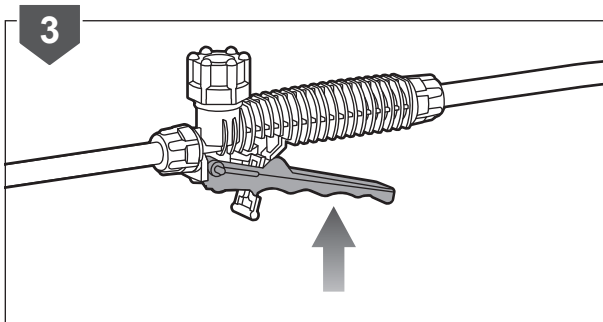
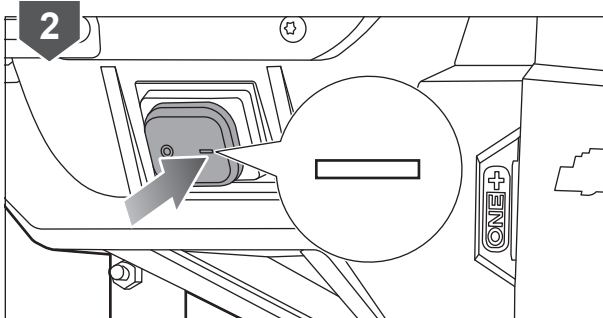
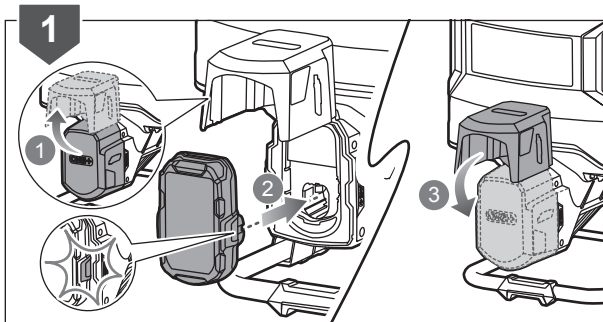
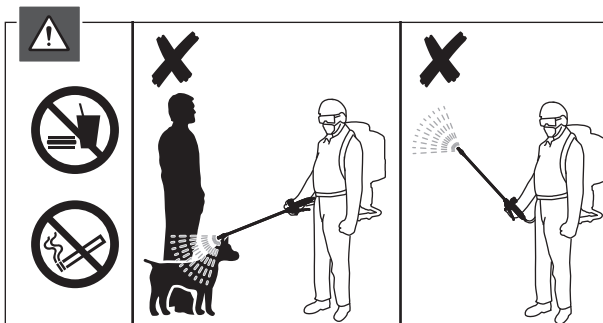

OPERATION

NOTE: The lock-on feature is convenient when spraying for an extended period of time or when covering a large area.

- To lock-on, squeeze the trigger and slide the locking tab backward.
- To release the lock-on, squeeze the trigger and slide the locking tab forward.

NOTE: Make sure the trigger is not locked on before inserting the battery pack into the sprayer.

4. Use the backpack sprayer with either the cone spray nozzle (left) or flat fan nozzle (right).

NOTE: The cone spray nozzle can be adjusted from a stream to a scatter spray.

- For a scatter spray, turn the nozzle clockwise.
- For a stream spray, turn the nozzle counterclockwise.

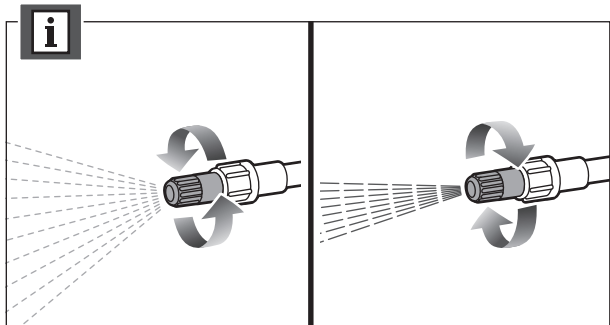
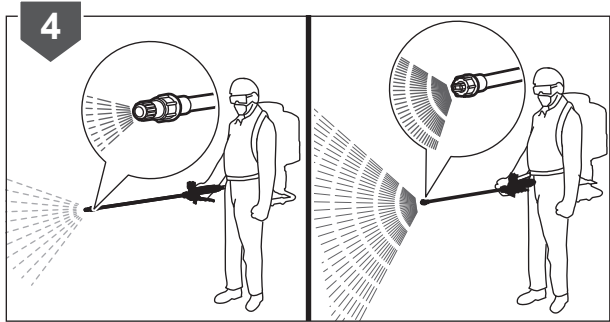
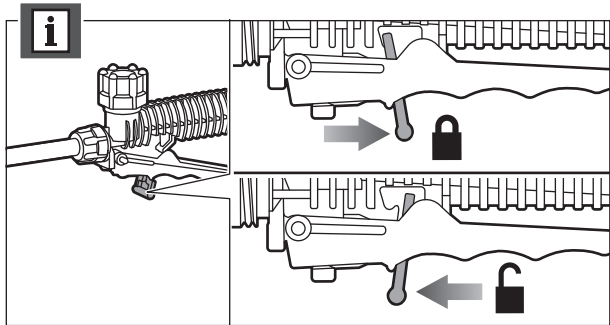

OPERATION

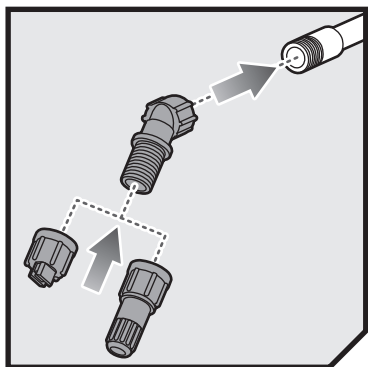

CONNECTING THE NOZZLE TO THE ELBOW

1. Turn off the product.
2. Loosen and remove the cone spray nozzle.
3. Install and tighten the elbow.
4. Install either the flat fan nozzle (left) or cone spray nozzle (right).

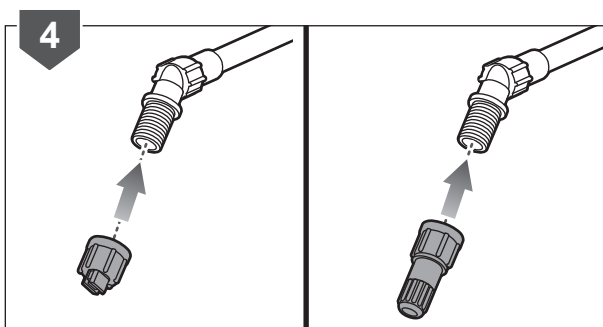
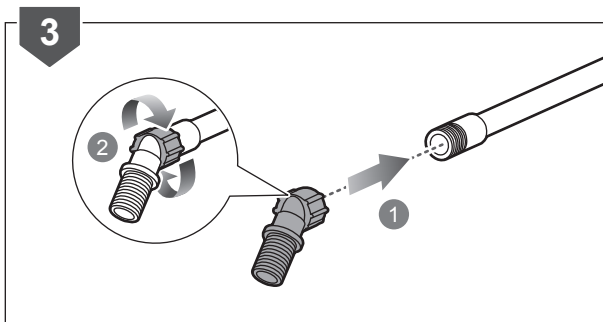
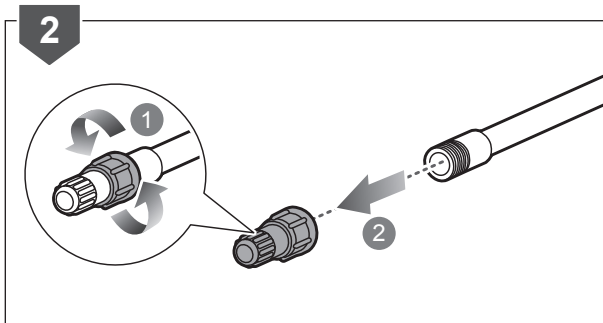
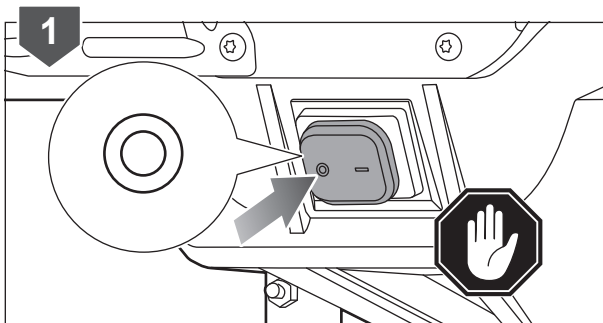

OPERATION

5. Tighten either the flat fan nozzle or cone spray nozzle.
To start the flow of liquid of the spray wand, squeeze the trigger.

NOTE: The flat fan nozzle provides a fan spray.

NOTE: For a scatter spray, turn the cone spray nozzle clockwise. For a stream spray, turn the cone spray nozzle counterclockwise.

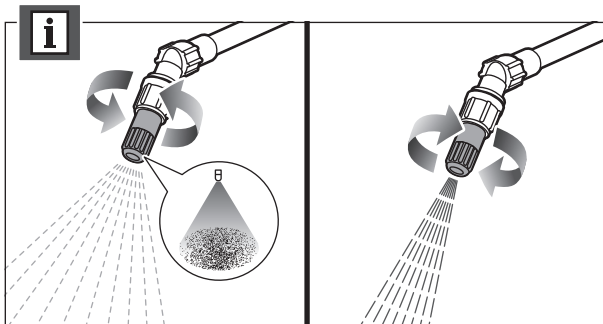
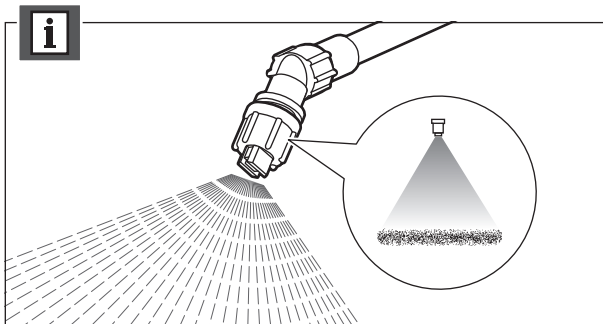
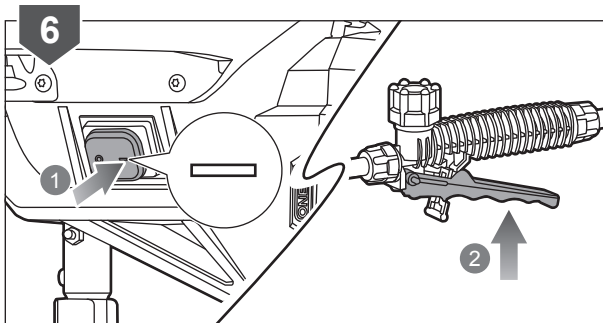
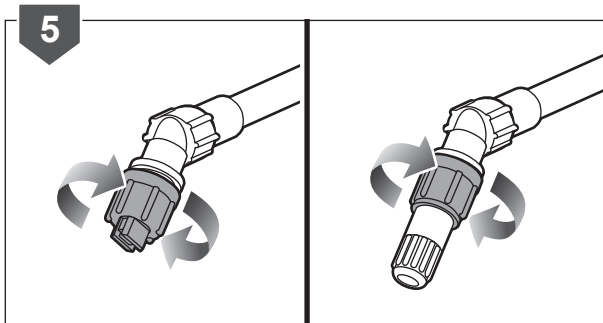

MAINTENANCE

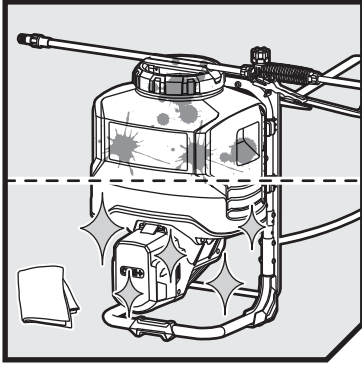

CLEANING THE PRODUCT

1. Remove the battery pack. Depress the latches on both sides to release the battery pack and remove it from the product.
2. Remove the tank cover.
3. Drain the contents of the tank.
4. Fill the spray tank about one-third full with clean water. A small amount of mild household detergent may be added. Reattach the tank cover.

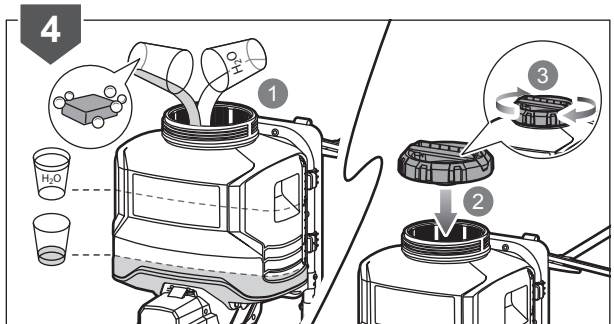
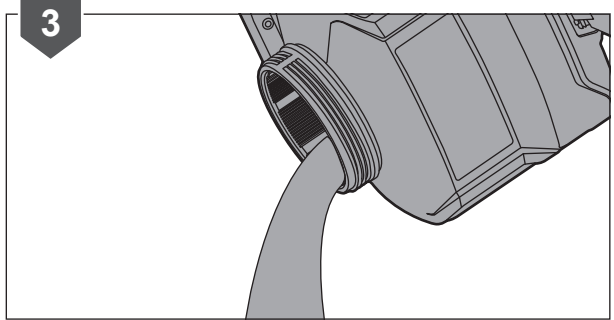
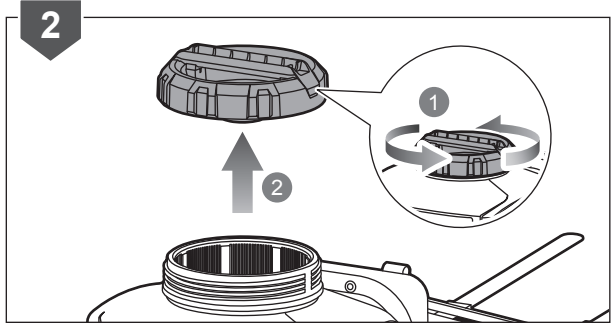
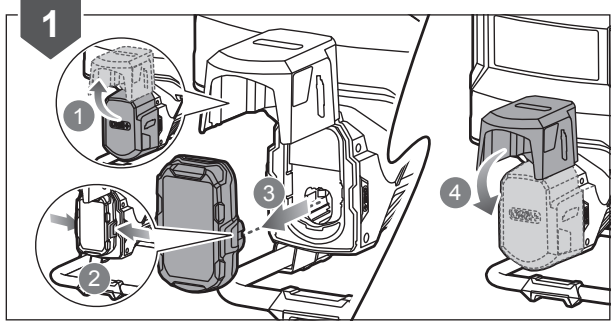

MAINTENANCE

5. Reinstall the battery.
6. Turn on the product.
7. Squeeze the trigger to start the flow of liquid.

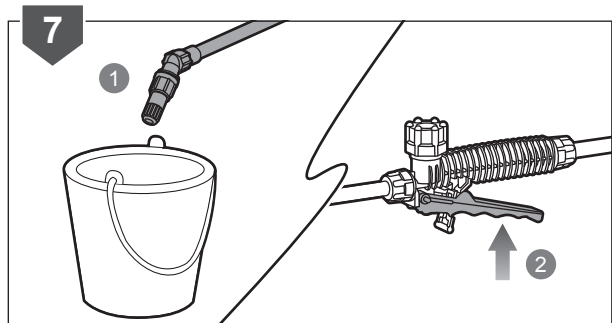
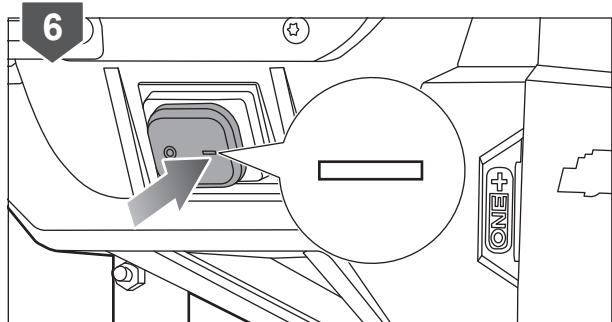
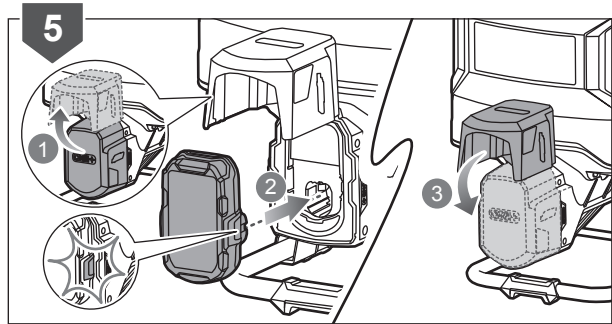

NOTE: Spray until the tank has been completely emptied.

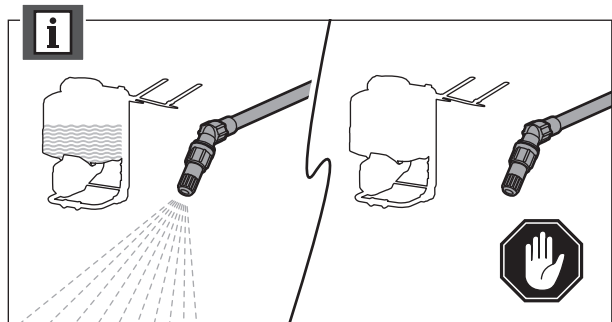

MAINTENANCE

8. Wipe the outside of the tank with a clean, dry cloth.

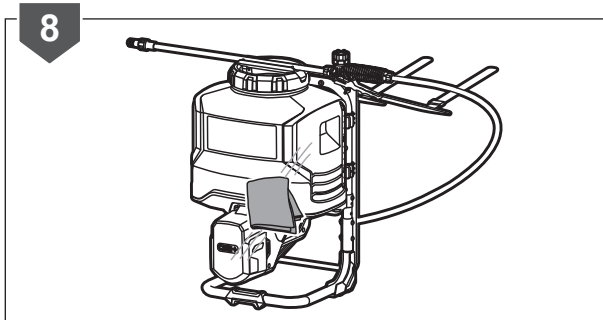

MAINTENANCE

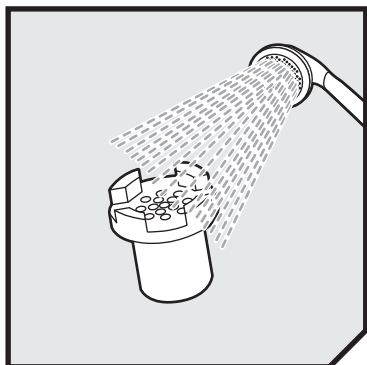

CLEANING THE PLASTIC FILTER

1. Remove the battery pack. Depress the latches on both sides to release the battery pack and remove it from the product.
2. Remove the tank lid and the basket filter.
3. Remove the pick-up tube and filter assembly.
4. Remove the plastic filter.

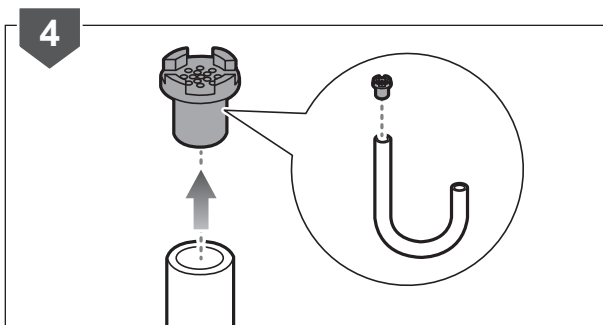
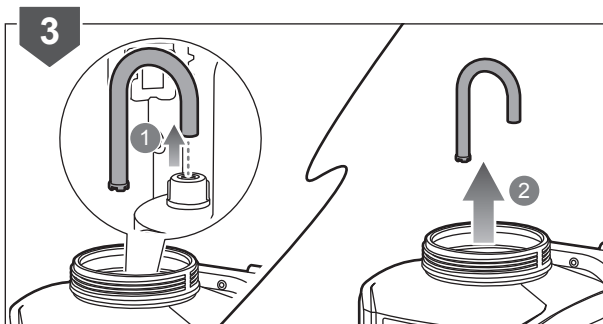
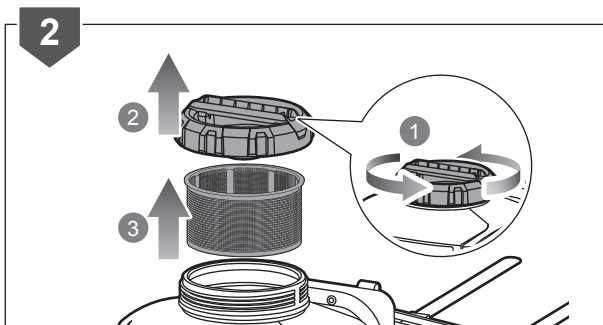
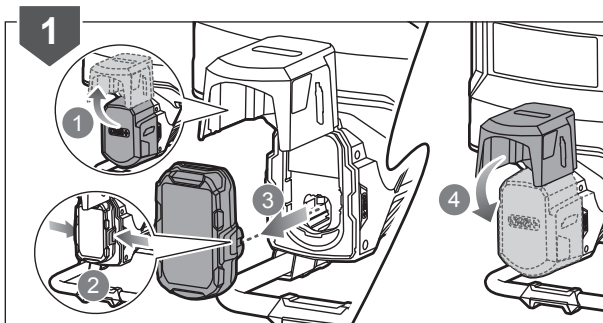

MAINTENANCE

5. Rinse the plastic filter with clean water.
6. Reinstall the plastic filter to the pick-up tube.
7. Reinstall the pick-up tube and filter assembly.
8. Reinstall the tank lid and the basket filter.

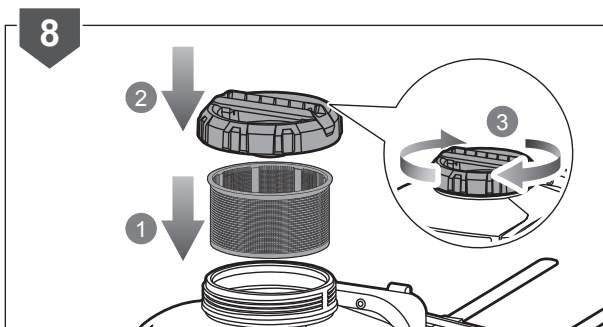
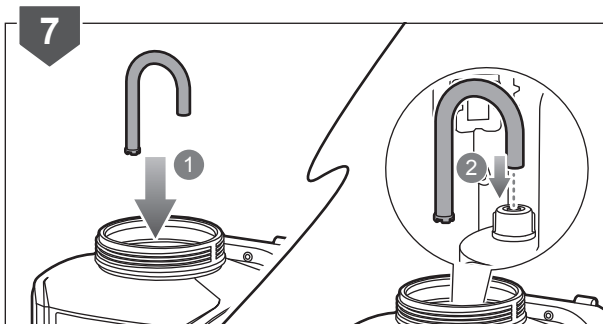
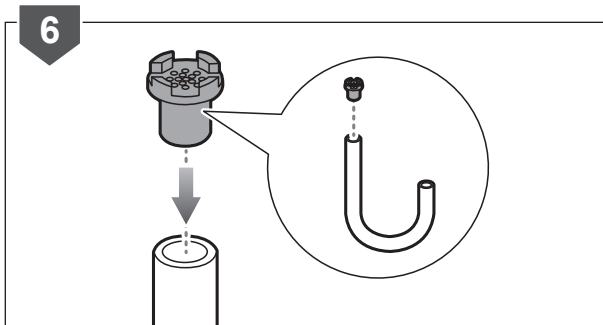
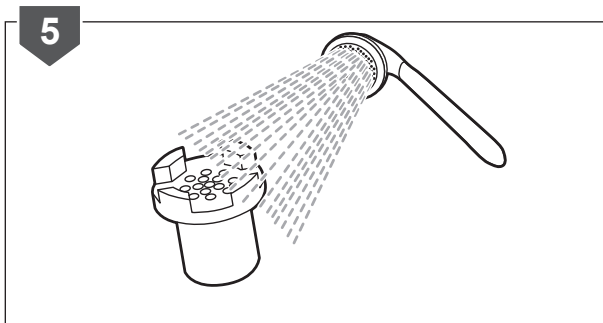

STORAGE

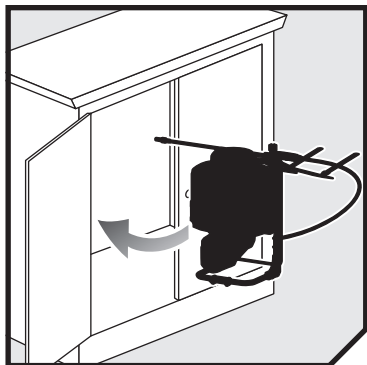

STORING THE PRODUCT

1. Remove the battery pack. Depress the latches on both sides to release the battery pack and remove it from the product.
2. Place the nozzle wand (either on the side or on top) into the holder until it snaps into place.
3. Store the product in a cool, dry, and well-ventilated place that is inaccessible to children. Keep away from corrosive agents such as garden chemicals and de-icing salts. Do not store the product outdoors.

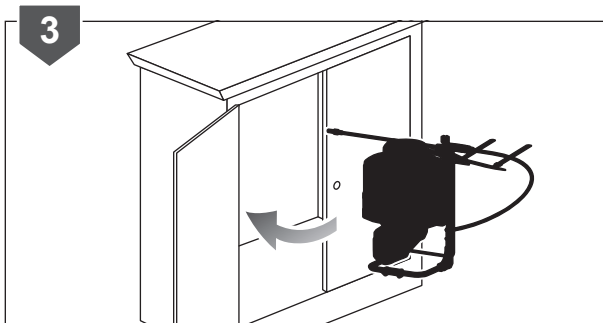
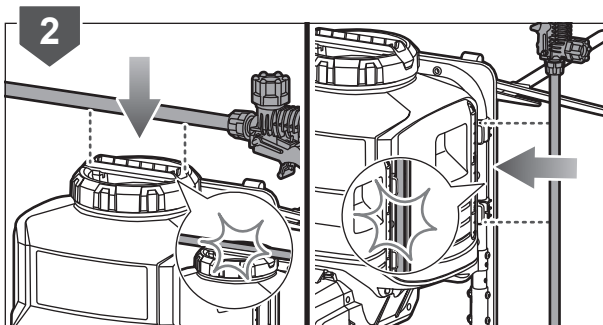
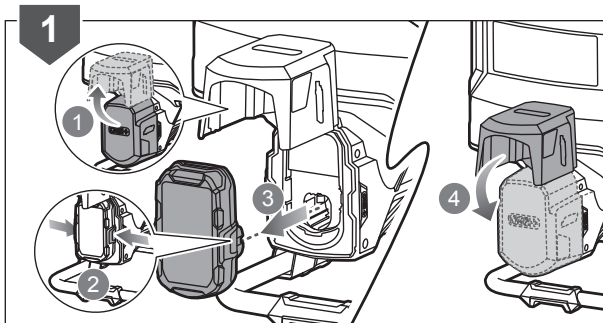

PRODUCT SPECIFICATIONS

Model	OWS1815
Pump type	Diaphragm pump
Spray valve	Integral grip lever
Tank capacity	15 L
Dimension (WxLxH)	340 x 360 x 540 mm
Gross mass (empty)	6.35 kg (without battery)
Gross mass (full)	22 kg
Rated voltage	18 V DC
Operating temperature (max)	40°C
Flow rate	
Flat fan nozzle	
Fan	1400 mL/min at 58 psi
Cone spray nozzle	
Stream	1300 mL/min at 61 psi
Scatter	1000 mL/min at 84 psi
Working pressure (maximum)	90 psi (static pressure)
Residual solution in tank (max)	250 mL
Size of filler strainer mesh	1.3 mm
A-weighted emission sound pressure level at the operator's position	70 dB (A)
Vibration values determined according to EN 60745-1	
Main handle	1.87 m/s ²
Uncertainty	1.5 m/s ²

BATTERY AND CHARGER

Model	OWS1815
Compatible battery packs	RB18L13, RB18L15, RB18L20, RB18L25, RB18L40, RB18L50
Compatible chargers	BCS618G, BCL14181H, BCL14183H, BCL14181V, RC18150U, RC18627U, RC18120, RC18115

REPLACEMENT PARTS

Nozzle and Wand Assembly	313969001
Handle and Hose Assembly	564605002
Basket Filter	313531001
Pick-up Tube	314681001

NOTE: Visit your local special orders desk or contact RYOBI Customer Service for replacement parts.

VIBRATION LEVEL

WARNING

The declared vibration value has been measured with a standard test method and may be used to compare one tool with another.

The declared vibration value may be used in a preliminary assessment of exposure.

The vibration emission during actual use of power tool can differ from the declared total value depending on the ways in which the tool is used.

Identify safety measures to protect yourself based on an estimation of exposure in the actual conditions of use, taking account of all parts of the operating cycle such as the times when the tool is switched off and when it is running idle in addition to the trigger time.









Imported by:

Techtronic Industries Australia Pty Ltd
31 Gilby Road, Mount Waverley, VIC 3149
Melbourne, Australia

Techtronic Industries N.Z. Limited
2 Landing Drive, Mangere
Auckland, 2022, New Zealand