

# Vertical Black Glass Wall mounted 90cm Rangehood



## Model: RHGV90

- Under glass ESTC Electronic Sensor touch Controls
- Dual blade Black Krystal glass construction with stainless steel flue
- Optional carbon filters available for recirculating installation
- 4 extraction speeds including Boost
- Two 1.5w LED lamps with on and off soft fade
- Dual level venting to maximise performance
- Twin access washable 5-layer aluminium grease filters
- Low energy motor for reducing power consumption
- 12% more powerful performance 900 m<sup>3</sup>/h
- 16% quieter 47dbA with Kleenmaid's Whisper technology
- Wireless remote control
- Automatic run-on timer
- Non-return protection for external air
- 150mm diameter air venting for superior air flow



Whisper



Low Energy  
Motor

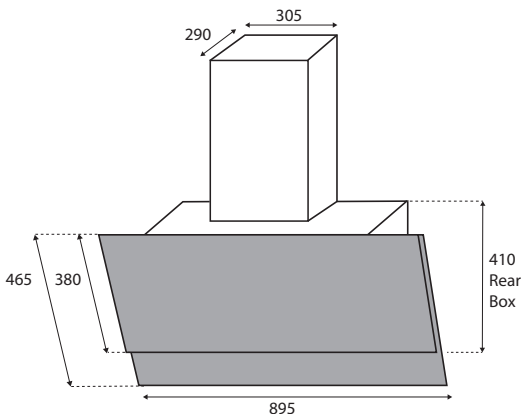

QUALITY ASSURED

J10703\_21