

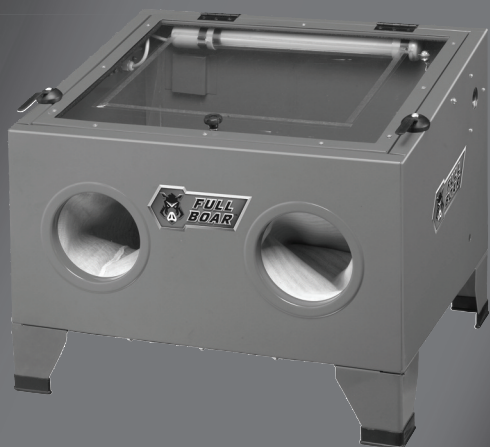

SANDBLASTING CABINET

- **TOP LOAD CABINET**
- **LARGE VIEWING WINDOW**
- **10KG SANDBLASTING GRIT**
- **HOME GARAGE OR WORKSHOP**



INSTRUCTION MANUAL

⚠ WARNING: Read all safety warnings and all instructions. Failure to follow the warnings and instructions may result in electric shock, fire and/or serious injury. Save all warnings and instructions for future reference.

SPECIFICATIONS - MODEL NO. FBT-6600

Input Adaptor:	100-240V AC 50/60Hz 0.35A
Output:	12V / 8W
Connection Thread:	NPT
Overall Dimension:	58.5x48.5x48.5cm
Working Dimensions:	56x46x28cm
Recommended Air Supply:	5 to 14CFM
Recommended Air Pressure:	345 to 620kpa (50 to 90psi)
Weight:	20Kgs

KNOW YOUR PRODUCT

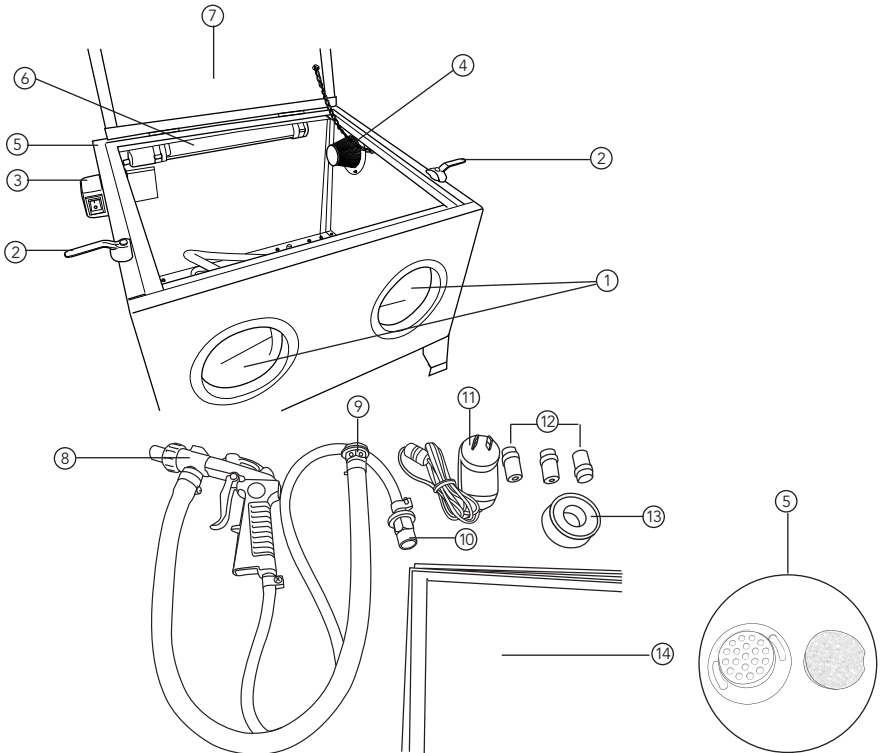

1. Gloves
2. Lid locks
3. On /Off light switch
4. Filter
5. Rear Exhaust filter
6. Fluro Lamp
7. Lid
8. Blast gun

9. Media hose connection
10. Air hose connection
11. Transformer with cable
12. Ceramic nozzles 4, 5, 6, 7mm
(1 x fitted)
13. PTFE tape
14. Spare protective sheets x 10

TABLE OF CONTENTS

SPECIFICATIONS.....	Page 2
KNOW YOUR PRODUCT.....	Page 2
INTRODUCTION.....	Page 4
SAFETY INSTRUCTIONS.....	Page 4
ASSEMBLY.....	Page 7
OPERATION	Page 8
MAINTENANCE	Page 9
CONTENTS	Page 11
WARRANTY.....	Page 12

INTRODUCTION

Congratulations on purchasing a Full Boar Sandblast Cabinet.

Your Full Boar Cabinet FBT-6600 has been designed to be an effective cleaning system that will revitalise most metal objects, that need their surface cleaned or have an unwanted coating.

SAFETY INSTRUCTIONS



Warning! When using mains-powered equipment, basic safety precautions, including the following, should always be followed to reduce risk of fire, electric shock, personal injury and material damage.

Read and understand the manual prior to operating this tool.

Save these instructions and other documents supplied with this tool for future reference.

ELECTRICAL SAFETY

The electric motor has been designed for 230V and 240V only. Always check that the power supply corresponds to the voltage on the rating plate.

Note: The supply of 230V and 240V on Full Boar tools are interchangeable for Australia and New Zealand.

If the supply cord is damaged, it must be replaced by an electrician or a power tool repairer in order to avoid a hazard.

Using an Extension Lead

Always use an approved extension lead suitable for the power input of this tool. Before use, inspect the extension lead for signs of damage, wear and ageing. Replace the extension lead if damaged or defective.

When using an extension lead on a reel, always unwind the lead completely. Use of an extension lead not suitable for the power input of the tool or which is damaged or defective may result in a risk of fire and/or electric shock.

It is recommended that the extension lead is a maximum of 25m in length. Do Not use multiple extension leads.

GENERAL SAFETY INSTRUCTIONS



WARNING! Read all instructions. Failure to follow all instructions listed below may result in electric shock, fire and/or serious injury. The term “Power Tool” in all of the warnings listed below refers to your mains operated (corded) power tool or battery operated (cordless) power tool.

SAVE THESE INSTRUCTIONS

1. Work area safety

- a. Keep work area clean and well lit.** Cluttered or dark areas invite accidents.
- b. Do not operate power tools in explosive atmospheres, such as in the presence of flammable liquids, gases or dust.** Power tools create sparks which may ignite the dust or fumes.
- c. Keep children and bystanders away while operating a power tool.** Distractions can cause you to lose control.

2. Electrical safety

- a. Power tool plugs must match the outlet. Never modify the plug in any way. Do not use any adapter plugs with earthed (grounded) power tools.** Unmodified plugs and matching outlets will reduce risk of electric shock.
- b. Avoid body contact with earthed or grounded surfaces, such as pipes, radiators, ranges and refrigerators.** There is an increased risk of electric shock if your body is earthed or grounded.
- c. Do not expose power tools to rain or wet conditions.** Water entering a power tool will increase the risk of electric shock.
- d. Do not abuse the cord. Never use the cord for carrying, pulling or unplugging the power tool. Keep cord away from heat, oil, sharp edges or moving parts.** Damaged or entangled cords increase the risk of electric shock.
- e. When operating a power tool outdoors, use an extension cord suitable for outdoor use.** Use of a cord suitable for outdoor use reduces the risk of electric shock.
- f. If operating a power tool in a damp location is unavoidable, use a residual current device (RCD) protected supply.** Use of an RCD reduces the risk of electric shock.

3. Personal safety

- a. Stay alert, watch what you are doing and use common sense when operating a power tool. Do not use a power tool while you are tired or under the influence of drugs, alcohol or medication.** A moment of inattention while operating power tools may result in serious personal injury.
- b. Use personal protective equipment. Always wear eye protection.** Protective equipment such as dust mask, non-skid safety shoes, hard hat, or hearing protection used for appropriate conditions will reduce personal injuries.
- c. Prevent unintentional starting. Ensure the switch is in the off-position before connecting to power source and/or battery pack, picking up or carrying the tool.** Carrying power tools with your finger on the switch or energising power tools that have the switch on invites accidents.

GENERAL SAFETY INSTRUCTIONS (cont.)

d. Remove any adjusting key or wrench before turning the power tool on. A wrench or a key left attached to a rotating part of the power tool may result in personal injury.

e. Do not overreach. Keep proper footing and balance at all times. This enables better control of the power tool in unexpected situations.

f. Dress properly. Do not wear loose clothing or jewellery. Keep your hair, clothing and gloves away from moving parts. Loose clothes, jewellery or long hair can be caught in moving parts.

g. If devices are provided for the connection of dust extraction and collection facilities, ensure these are connected and properly used. Use of dust collection can reduce dust-related hazards.

4. Power tool use and care

a. Do not force the power tool. Use the correct power tool for your application. The correct power tool will do the job better and safer at the rate for which it was designed.

b. Do not use the power tool if the switch does not turn it on and off. Any power tool that cannot be controlled with the switch is dangerous and must be repaired.

c. Disconnect the plug from the power source and/or the battery pack from the power tool before making any adjustments, changing accessories, or storing power tools. Such preventive safety measures reduce the risk of starting the power tool accidentally.

d. Store idle power tools out of the reach of children and do not allow persons unfamiliar with the power tool or these instructions to operate the power tool. Power tools are dangerous in the hands of untrained users.

e. Maintain power tools. Check for misalignment or binding of moving parts, breakage of parts and any other condition that may affect the power tool's operation. If damaged, have the power tool repaired before use. Many accidents are caused by poorly maintained power tools.

f. Keep cutting tools sharp and clean. Properly maintained cutting tools with sharp cutting edges are less likely to bind and are easier to control.

g. Use the power tool, accessories and tool bits etc. in accordance with these instructions, taking into account the working conditions and the work to be performed. Use of the power tool for operations different from those intended could result in a hazardous situation.

5. Service

a. Have your power tool serviced by a qualified repair person using only identical replacement parts. This will ensure that the safety of the power tool is maintained.

b. If the supply cord of this power tool is damaged, it must be replaced by the manufacturer, its service agent or similarly qualified persons in order to avoid a hazard.

ASSEMBLY

Unpacking:

- Open carton and remove packing material.
- Carefully lift the Sandblasting Cabinet from the packaging and place it on a level work surface.
- Unpack the contents.
- The air hose connector (10) from the blast gun (9) needs connecting to the side wall of the cabinet. Use the PTFE tape (11) on thread to ensure an air tight seal (Fig.1).

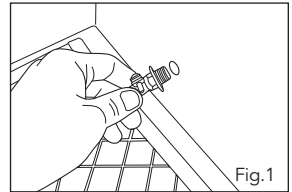

- Fit a washer to the inside, and on the outside apply washer, PTFE tape (11) to the thread and then tighten the nut. Use a 18mm spanner (not supplied) to tighten (Fig.2).

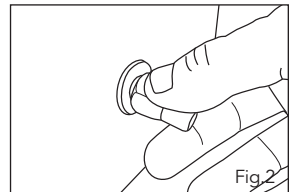

- The hose with the media connection (9) fitted needs to be fitted through the centre hole on the base of the cabinet (Fig 3).

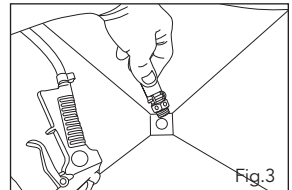

- Turn the unit on its side or back to get at the washer and nut. Use a 24mm spanner (not supplied) to tighten. No need for PTFE tape (13) (Fig 4).

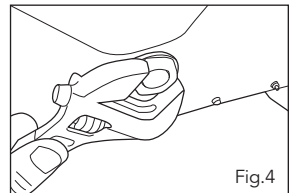

- On the rear of the unit fit the Exhaust filter (5). Use a screwdriver (not supplied) to tighten (Fig.5).

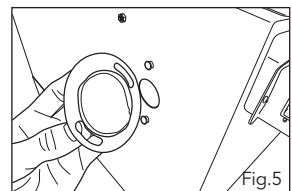

OPERATION

- Plug the transformer (11) cable connector to the back of the On/Off light switch (3) and mains socket or extension lead. Switch on the fluro lamp (6) by pushing the On/Off light switch (3) to "I" (On) (Fig 6).

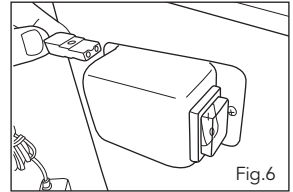

- Ensure the air line from the compressor is connected and secure (Fig 7).

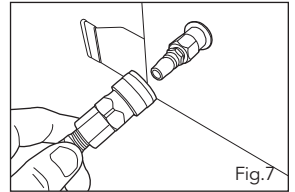

- Place the grid into the cabinet, so that it sits flat on the shelf and not on the media hose (Fig.8).

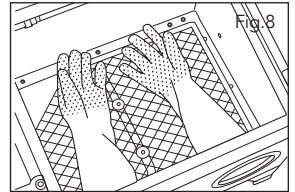

- Pour in the abrasive media to be used.
Do not fill the abrasive media higher than the level of the grid, but enough so the supply is not interrupted, when spraying.
- Select the ceramic nozzle (12) to produce the jet required for the abrasive media being used.

Note: The smaller the ceramic nozzle (12) the finer the spray.

- Place the object to be cleaned in the cabinet on the grid. In the middle towards the back, to allow movement with blast gun (8) and gloves (1).
- Close the lid (7), securing it down with the two lid locks (2) (Fig 9).

Note: replace the protective sheet (14) on the clear lid (7) if the view into the cabinet is not clear.

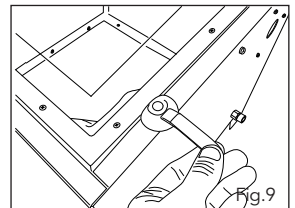

- Switch the air supply ON, let it build up to the desired pressure not higher than 100psi. Recommended air supply 5 – 14 CFM. Adjust the air pressure to the media being used, and the object being cleaned. This will come with practice.



WARNING! Keep the jet facing the object or the grid, do not allow the jet to train on the rubber gloves (1), fluorescent lamp (6) or the clear lid (7).

- When complete, release blast gun (8) trigger, turn off the air supply. Wait a few seconds for the dust to settle and then open the lid (7).

OPERATION (cont.)

Notes

- There are no hard or fast rules governing the ceramic nozzle (12) sizes and air pressure used with different abrasive media. With experience and experimentation you will quickly learn the best combination for the required result.
- On more delicate objects start with minimal air pressure to avoid unnecessary peening or excessive abrasion, and work up to a setting to produce the desired finish.
- Change the abrasive media regularly as it loses its effectiveness after a while.

MAINTENANCE



WARNING! Ensure air supply is disconnected before performing this operation.

- Always ensure the air supply and the power supply are disconnected before completing maintenance work.
- The clear lid has been protected with a shield, these can be replaced when they get cloudy and worn or heavily blasted. Just peel off carefully wipe the lid and stick on a new one.
- Ensure the air vents and filters are cleaned regularly
- Clean the seal around the lid, this will ensure no dust or debris escapes.

Changing the Ceramic Nozzle (12) (Fig. 10)

- Pull the trigger of the blast gun (8) as a precaution.
- Unscrew the end cap and withdraw the ceramic nozzle (12).
- Replace with the ceramic nozzle (12) of your choice and carefully thread the end cap back on to the blast gun (8). Take care not to cross thread the thread.

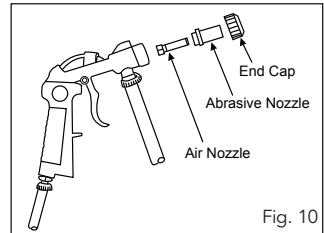

Fig. 10

Changing the Fluorescent Tube

- Ensure the transformer (11) is unplugged and disconnected.
- Cut the two cable ties holding the fluro lamp (6) retaining clips.
- Carefully pull the fluro lamp (6) from its retaining clips, then holding the clear plastic protective outer tube and ease off the non wired end.
- Pull off the end connector which secures a wire to one of the pins, taking care not to distort the aluminium reflector. Then pull off the wire secured by a plastic sheath to one of the pins at the cable input end.
- Get the new Fluorescent tube and assemble in reverse order, ensuring the wires are correctly held by the plastic sheath at one end and the end connector at the other, with the reflector correctly in position.
- Refit the assembly into its retaining clips. New cable ties will be required to hold clips together.
- Plug in transformer (11) and switch the lamp ON ("I").

Gloves

- Check the gloves (1) regularly. If any cracks or tears are evident they will need to be replaced.

TROUBLE SHOOTING

Problem	Cause	Remedy
Excessive dust in cabinet.	Rear Exhaust filter is plugged or air-flow is blocked.	Clean rear vent and keep vent away from the wall.
	Abrasive media worn.	Replace abrasive media.
	Excessive abrasive media inside cabinet.	Remove excess media.
	Loose air hose or fitting connections.	Tighten fittings and make sure air hose is secure.
Uneven blasting actions.	Excessive abrasive media inside cabinet.	Remove the excess media.
	Moisture present inside the cabinet.	Check air hose to make sure there is no moisture in it; Replace media if it has absorb the moisture.
	Blast gun has a blockage.	Disassemble and clean blockage.
Inadequate speed or inefficiency of blast.	Abrasive media worn.	Replace abrasive media.
	Pressure is too low.	Increase inlet pressure and make sure the control valve is fully opened.
Static electricity.	Dry weather conditions.	leave the item being cleaned on the grating.
Media leaking from Lid.	Air pressure is set to high.	Decrease inlet pressure.
	Lid seal is damaged.	Replace damaged lid seals.

CARING FOR THE ENVIRONMENT

















Power tools that are no longer usable should not be disposed of with household waste but in an environmentally friendly way. Please recycle where facilities exist. Check with your local council authority for recycling advice.

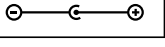

Recycling packaging reduces the need for landfill and raw materials. Reuse of recycled material decreases pollution in the environment. Please recycle packaging where facilities exist. Check with your local council authority for recycling advice.

DESCRIPTION OF SYMBOLS

V	Volts	Hz	Hertz
~	Alternating current	W	Watts
dc / 	Direct current	∅	Diameter
mA	Milliamperes	Ah	Amp hour
/min	Revolutions or reciprocation per minute	no	No load speed
	Regulator compliance mark		Double insulated
	Warning		Read instruction manual
	Do not operate in the rain		Indoor use only
	The sound power level indicates by L _{WA} in dB		Wear eye protection
	Transformer Energy Rating (MEPS)		Keep bystanders away
	Isolation transformer		Polarity
	Thermal cut-out protection at 130°C		

CONTENTS

1 x Sandblasting Cabinet	1 x 10kg Sandblasting Grit
1 x Gun, Air & Pick Up Hose	1 x PTFE Tape
4 x Ceramic Nozzles (4,5,6 & 7mm)	1 x Exhaust Filter
10 x Protective Sheets	1 x Instruction Manual
1 x 12V Adaptor	

Distributed by:
Ozito Industries Pty Ltd

AUSTRALIA (Head Office)

1-23 Letcon Drive, Bangholme Victoria, Australia, 3175
Telephone: 1800 069 486

WARRANTY

YOUR WARRANTY FORM SHOULD BE RETAINED BY YOU AT ALL TIMES. IN ORDER TO MAKE A CLAIM UNDER THIS WARRANTY YOU MUST RETURN THE PRODUCT TO YOUR NEAREST BUNNINGS WAREHOUSE (see www.bunnings.com.au or www.bunnings.co.nz for store locations) WITH YOUR BUNNINGS REGISTER RECEIPT. PRIOR TO RETURNING YOUR PRODUCT FOR WARRANTY PLEASE TELEPHONE OUR CUSTOMER SERVICE HELPLINE:

**Australia 1800 069 486
New Zealand 0508 069 486**

TO ENSURE A SPEEDY RESPONSE PLEASE HAVE THE MODEL NUMBER AND DATE OF PURCHASE AVAILABLE. A CUSTOMER SERVICE REPRESENTATIVE WILL TAKE YOUR CALL AND ANSWER ANY QUESTIONS YOU MAY HAVE RELATING TO THE WARRANTY POLICY OR PROCEDURE.

1 YEAR WARRANTY

Your product is guaranteed for a period of **12 months from the original date of purchase**. If a product is defective it will be repaired in accordance with the terms of this warranty. Warranty excludes consumable parts, for example: wheels, bearings.

The benefits provided under this warranty are in addition to other rights and remedies which are available to you under law. The warranty covers manufacturer defects in materials, workmanship and finish under normal use.

Our goods come with guarantees that cannot be excluded under Australian Consumer law & Consumer Guarantees Act 1993 (NZ). You are entitled to a replacement or refund for a major failure and to compensation for other reasonably foreseeable loss or damage. You are also entitled to have the goods repaired and replaced if the goods fail to be of acceptable quality and the failure does not amount to a major failure.

WARRANTY EXCLUSIONS

The following actions will result in the warranty being void.

- If the tool has been operated on a supply voltage other than that specified on the tool.
- If the tool shows signs of damage or defects caused by or resulting from abuse, accidents or alterations.
- Failure to perform maintenance as set out within the instruction manual.
- If the tool is disassembled or tampered with in any way.
- The warranty excludes damage resulting from product misuse or product neglect.

This warranty is given by Ozito Industries Pty Ltd.

ABN: 17 050 731 756

Ph.1800 069 486

Australia/New Zealand (Head Office)
1-23 Letcon Drive, Bangholme, Victoria, Australia 3175