

BRITA Vivreau Vi Dispenser

Vi-1H Specifications



BRITA Vivreau Vi-1H dispenser the latest innovation from BRITA Vivreau. Dispenses Boiling and Chilled Still water from a single tap. BRITA Vivreau has set the standard with the new advanced BRITA Vivreau Boiler. Designed specifically with tea drinkers in mind, delivering unparalleled throughput of Boiling water at the correct temperature particularly at peak demand times.

Features

- New improved modern designed dispense tap
- Fits into a 400mm cupboard
- New high-spec boiler dispensing 3-4 cups per minute at up to 97°
- High performance Ice Bank refrigeration system delivering 80 litres of ice cold water per hour
- Touch control dispense with Hot water safety feature
- Can be installed in modular form to fit into the tightest of spaces
- Designed to fill water bottles without the need for font extension
- Perfect water flow with zero splash
- Plumbed to waste flush fitting drip tray
- Waste container with auto cut-off and alarm if waste provisions not available
- Removable dispense nozzle for improved hygiene
- Designed and manufactured in the U.K. and Europe
- Power saving option to reduce electricity consumption
- Anti-flood detection as standard
- Also available as floor-standing option with steel base cabinet
- BRITA filter fitted as standard

Product dispensed

Filtered Chilled Still and Hot water

Application

Designed typically to be installed within existing cupboard units for staff refreshments.

Equipment dimensions

Due to the fact that the equipment is installed in component part form, there are varying configurations for installation. As a guideline, a cupboard to the following dimensions will be sufficient:

- Width: 600mm
- Depth: 600mm
- Height: 800mm



Vi-1H Specifications

Dispense Taps (drilling templates available upon request)

Dimensions height 350mm plus additional 100mm clearance for operation.

Please note: that this system is installed as an under-counter unit. Alternatively it can be installed as a floor-standing unit or as part of a LinkLine system.

Installation specification

Installation must be done in accordance with AS/NZS 3500.1 and AS/NZS 3500.2

Within the plant cupboard the following services will be required:

- 1 x mains water supply terminating in a 15mm shut off valve (to connect to a 15mm compression fitting)
- Minimum water pressure 3.5 bar
- Minimum water flow 300 litres per hour
- 1 double x 10 amp electrical socket 220/240V AC 50hz
- Electrical run current 10 amps
- Energy: 2985W (max), 12.53 amps (max), power consumed during sleep mode (24 hours) 2.8Kwh, energy consumed for 12 hours operation 36Kwh, energy consumed for 1 hour operation 3.0Kwh
- 2 x vents (upper & lower) each equal to 140cm² of air flow (see attached guidelines)

If drip tray is to be plumbed to waste, we will require a trapped up stand to facilitate a ½" flexible pipe.

Location of services

Please ensure all services are kept within the rear 100mm of the system location.

Electrical socket is to be located in base cupboard unit at high level in either left or right corner (not beneath dispense tap).

Water shut-off valve to be located at low level. Please ensure that there is sufficient room for a 150mm long fitting to be connected to the shut-off valve. Top of waste up stand should be a maximum of 300mm from the base of the unit.

Please allow sufficient room for the Boiler (320mm x 130mm x 525mm(h)) to be located as close as possible to the dispense tap.

Insulation

Please ensure that all water pipes located in the BRITA Vivreau plant cupboard are correctly insulated to ensure that the water does not heat up within the pipes prior to entering the BRITA Vivreau system. This is essential for water quality reasons.

Floor standing

The BRITA Vivreau Vi-1H dispenser can be installed into a metal floor-standing unit and is free standing in your desired location.

For more information on the BRITA Vivreau Vi-1H dispenser, please call the numbers below.

BRITA Vivreau Vi Dispenser

Vi-1H Specifications

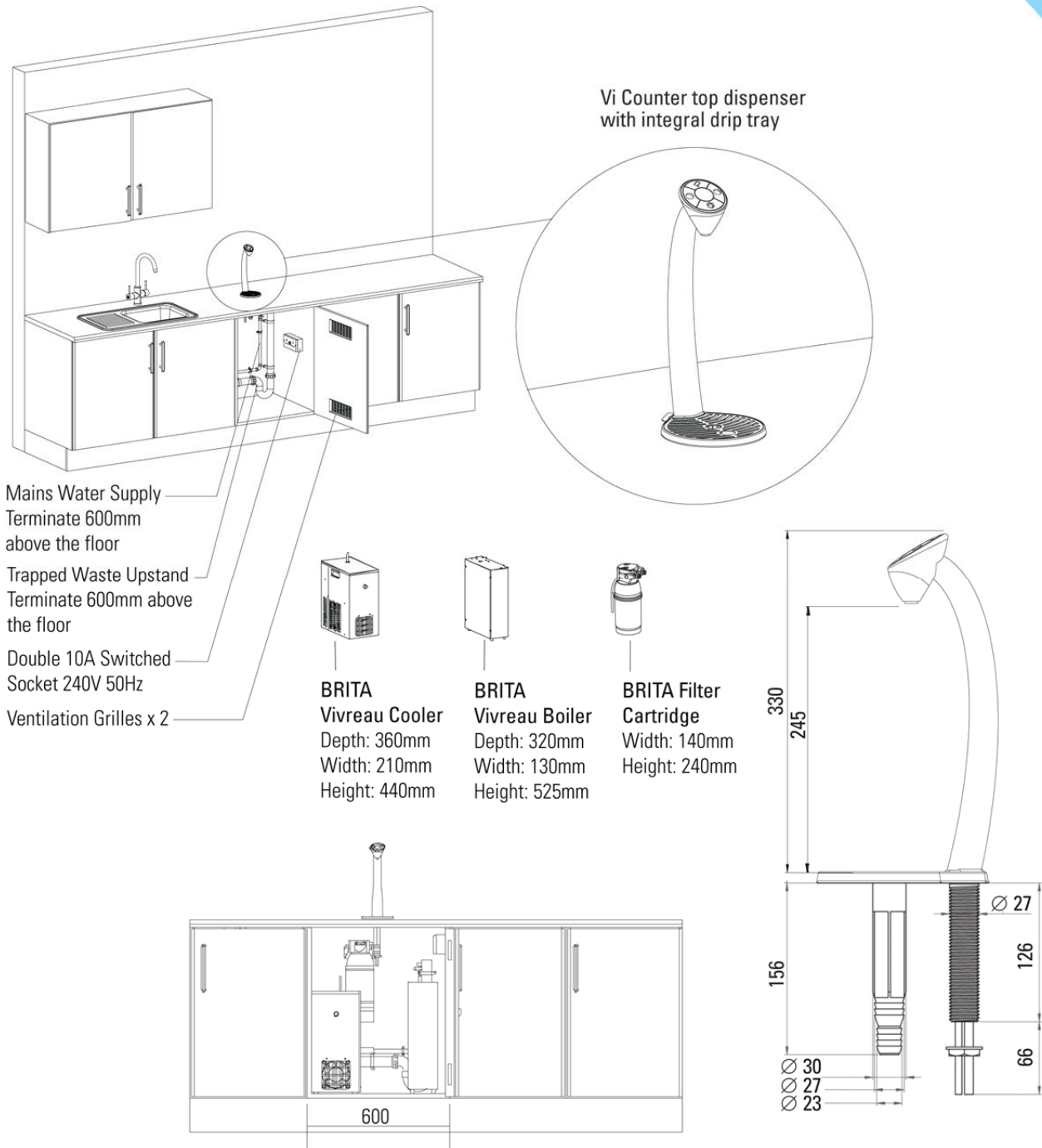

BRITA Vivreau Vi Dispenser

Installation dimensions worktop cut-out

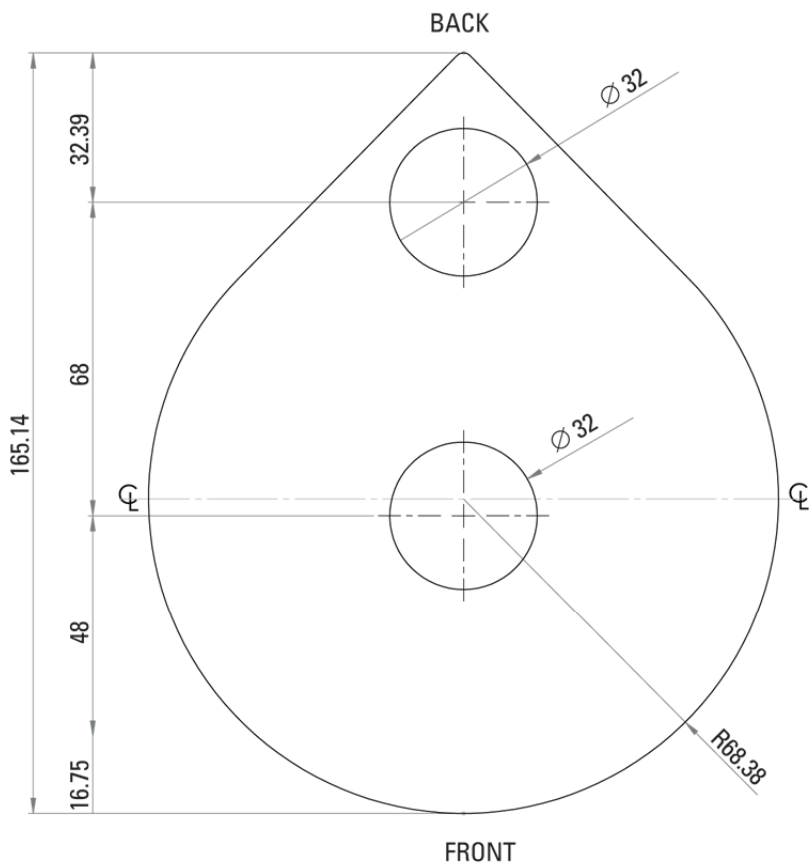

Please note: This drawing may be used in dxf or dwg for programmed routing. Alternatively the drawing may be printed at 100% on A4 as a template. (before cutting, check the dimensions have printed correctly)

Cutout Details:

The BRITA Vivreau Vi Dispenser is mounted in a single $\varnothing 30$ mm hole positioned approximately 20mm behind the back edge of the sink.

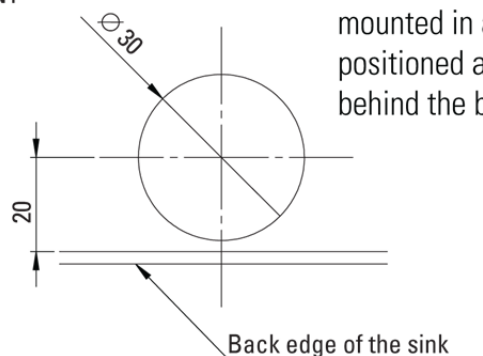

BRITA Vivreau Vi Dispenser

Methods of cabinet ventilation

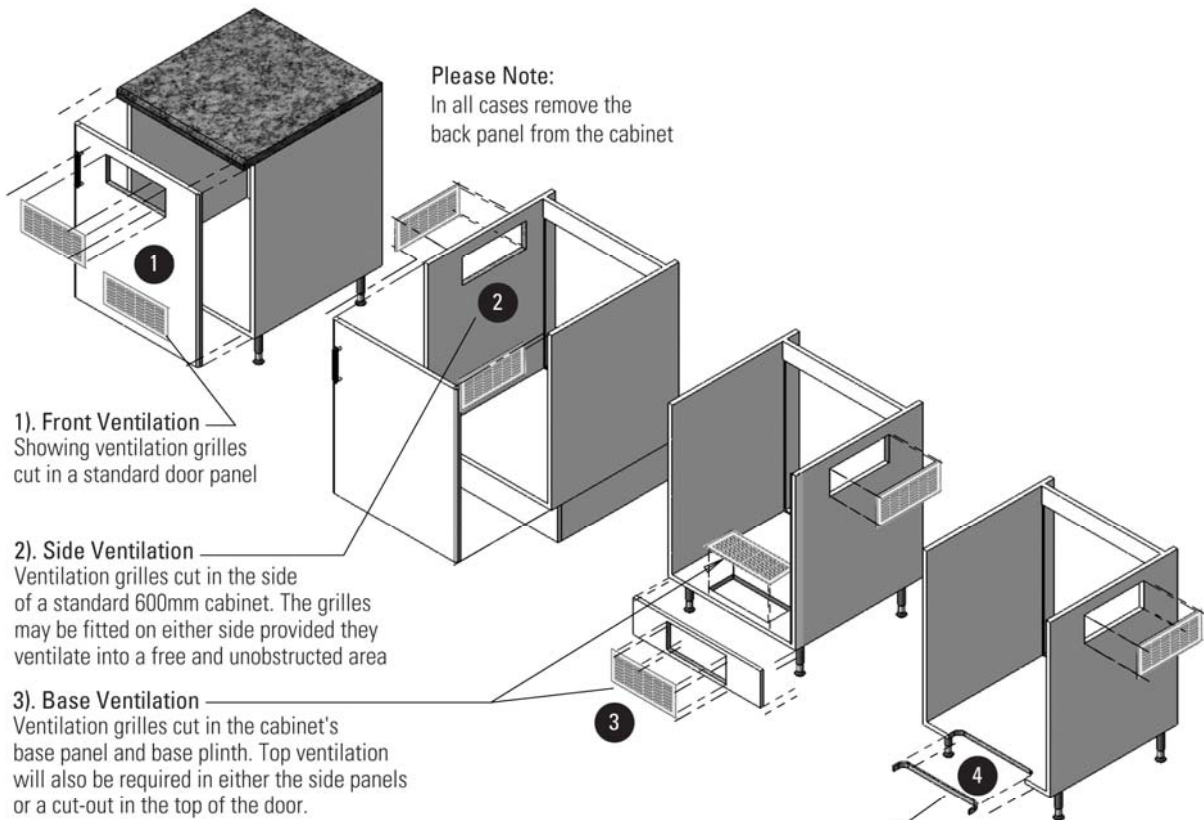

1). Front Ventilation
Showing ventilation grilles cut in a standard door panel

2). Side Ventilation
Ventilation grilles cut in the side of a standard 600mm cabinet. The grilles may be fitted on either side provided they ventilate into a free and unobstructed area

3). Base Ventilation
Ventilation grilles cut in the cabinet's base panel and base plinth. Top ventilation will also be required in either the side panels or a cut-out in the top of the door.

4). Base Cutout
Ventilation can be made to the base of the cabinet, with the removal of a narrow section of floor, immediately behind the door and trim with roll edging strip. Typical cut-out size must not be less than 280mm wide x 35mm deep

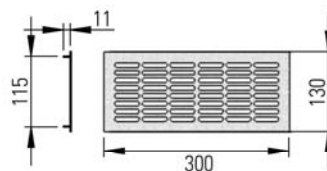

Standard BRITA
Vivreau grille

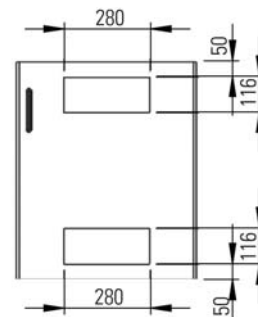

Cut-out detail for the standard 300mm BRITA Vivreau grille, shown in a 600mm wide door

The cabinet may be ventilated in several different ways to prevent excessive heat build-up. The methods shown all take advantage of natural circulation by placing two grilles or cut-outs; one near the base and the other at the top of the enclosure.