

TIMBER TOP WORKBENCH WITH PEGBOARD

1830H x 1200W x 540Dmm

ITEM NO: GOS072

Very Important: Unpack the unit and confirm that you have all the parts listed. Assemble the unit on a solid, level surface. Avoid carpet. You will need the assistance of a second person during assembly.
You will need the following: Phillips-head screwdriver, spanner and a rubber mallet or hammer.

**POWDER
COATED
BLACK**

SAFETY TIP:

When assembling or installing this product wear protective gloves and eyewear.

WARNING

SERIOUS INJURY OR DEATH CAN BE CAUSED BY TOPPLING FURNITURE

TO HELP PREVENT A TIP-OVER:

- We recommend you anchor this product to a wall or other suitable surface.
- Check anchors regularly

FOR MORE INFORMATION SEARCH: www.productsafety.gov.au

NO	PART NAME	PCS
(A)	Front left leg	1PC
(B)	Back left leg	1PC
(C)	Front right leg	1PC
(D)	Back right leg	1PC
(E)	Side benchtop support	2PCS
(F)	Front benchtop support	1PC
(G)	Horizontal side brace	2PCS
(H)	Horizontal back brace	1PC
(I)	Top left brace	1PC
(J)	Top right brace	1PC
(K)	Pegboard	2PCS
(L)	Timber benchtop	1PC
(M)	Tool tray	1PC
(N)	Tool tray bracket left	1PC
(O)	Tool tray bracket right	1PC
(P)	M8 x 13mm panhead hexbolt	16PCS
(Q)	M6 x 13mm panhead hexbolt	20PCS
(R)	M6 hex nut	5PCS
(S)	M5 x 16mm self-tapping screws	7PCS

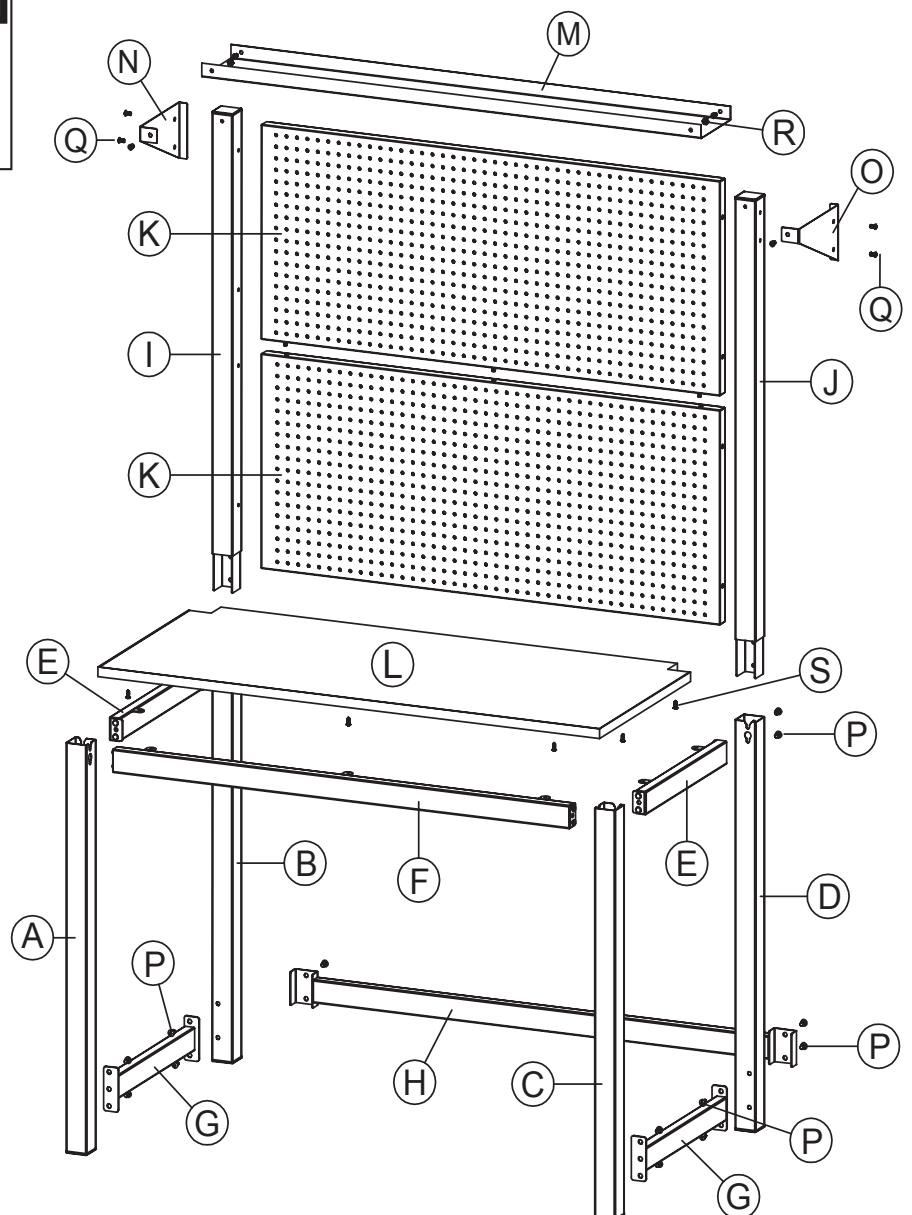

Step 1

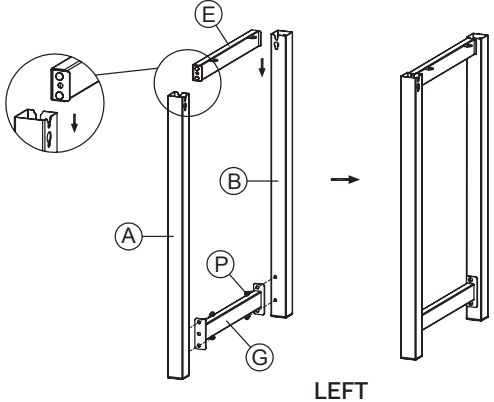

LEFT

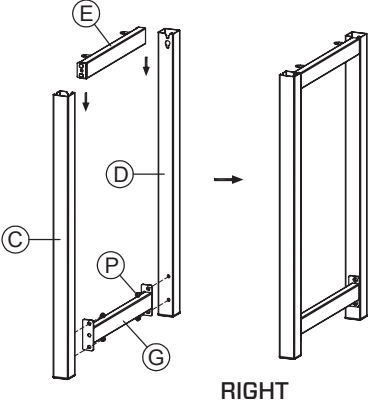

RIGHT

Step 2

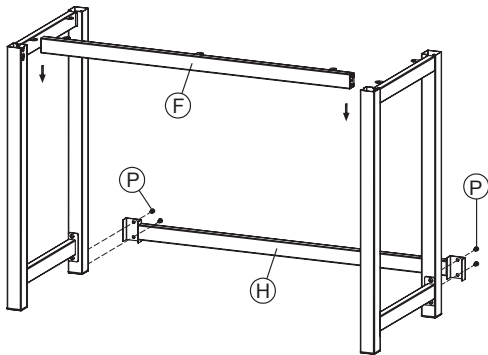

Step 3

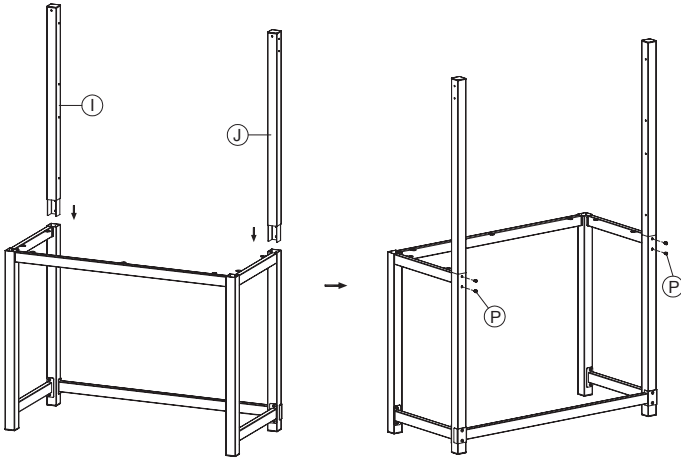

Step 4

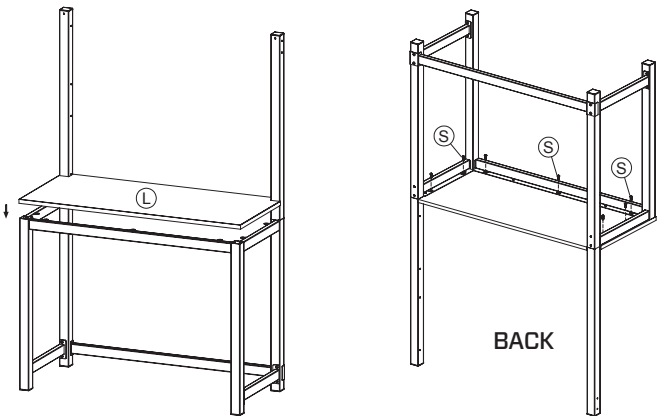

BACK

Step 5

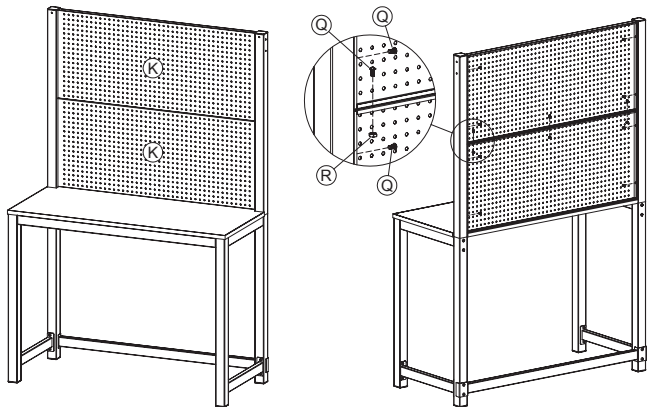

Step 6

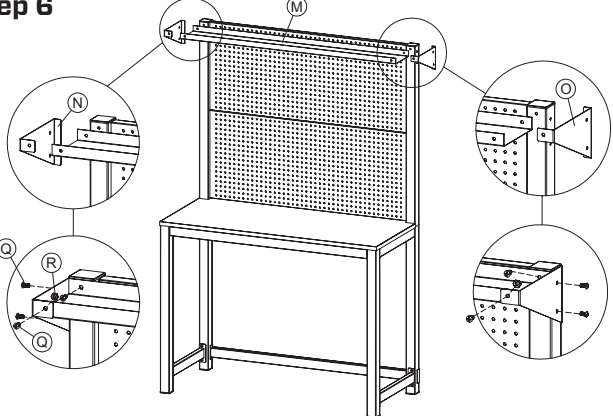

Step 7

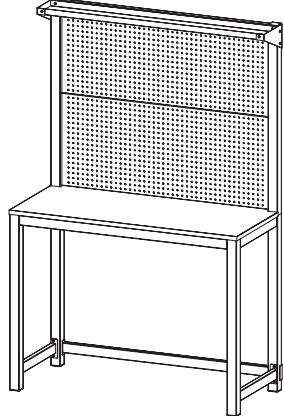

WARRANTY CONDITIONS
 Any claim under this warranty must be made within 1 year of the date of purchase of the product. To make a claim under this warranty, take the product (with proof of purchase) to any Bunnings store (see www.bunnings.com.au for store locations). Pinnacle Hardware bears reasonable, direct expenses of claiming under the warranty. You may submit details and proof of purchase to our support center for consideration. The warranty covers manufacturer defects in materials, workmanship and finish under normal use. This warranty is provided in addition to other rights and remedies you may have under law. Our goods come with guarantees that cannot be excluded under the Australian consumer law or Consumer Guarantees Act 1993 (NZ). You are entitled to a replacement or refund for a major failure and compensation for any other reasonably foreseeable loss or damage. You are also entitled to have the goods repaired or replaced if the goods fail to be of acceptable quality and the failure does not amount to a major failure. This warranty excludes damage resulting from product misuse or product neglect. The warranty covers domestic use only and does not apply to commercial applications. This warranty is given by Pinnacle Hardware, ABN 87 614 496 196, 28 Hudson Court, Keysborough Vic 3173, 1800 349 776, Email: support@pinnacle.net.au. New Zealand customers please contact HARCO (Harkness & Young Ltd), 09 27 64071, Email: sales@harknessyoung.co.nz. 'Pinnacle' is a trademark. © Pinnacle Hardware. Suitable for model number GOS072.