

ASSEMBLY INSTRUCTIONS FOR EXECUTIVE CORNER BASE ASSEMBLY

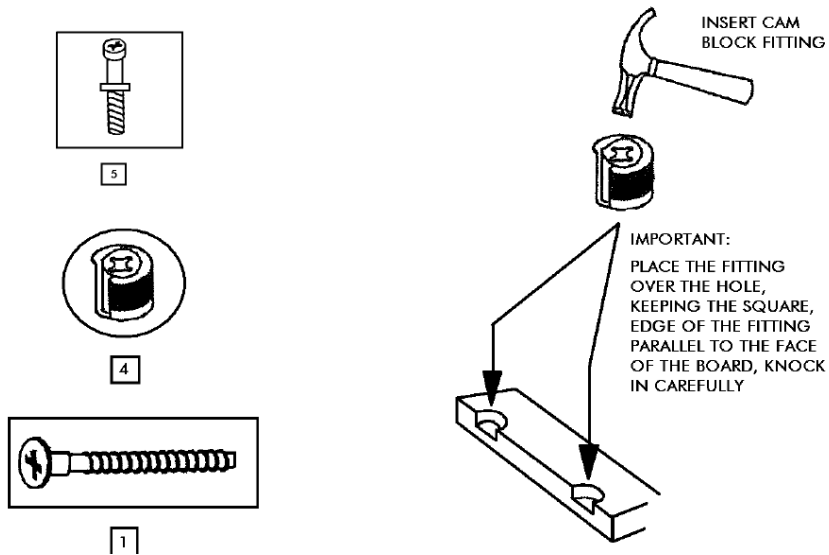
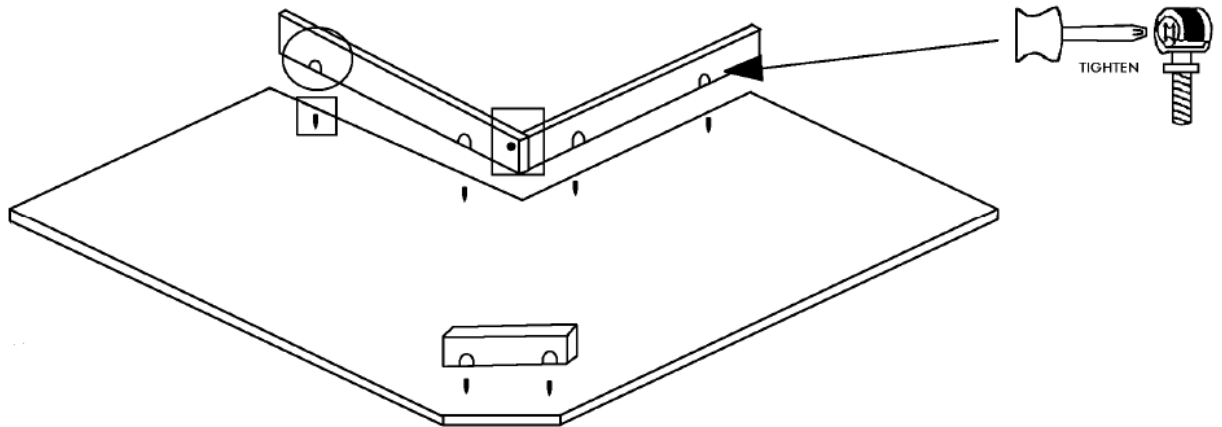

HARDWARE LIST

NO	MODEL	DESCRIPTIONS	QTY
1		M 50 x 5mm CONFIRMAT SCREWS	42
2		WHITE CAPS	31
3		SHELF SUPPORT PINS	10
4		CAM LOCK BLOCK	6

NO	MODEL	DESCRIPTIONS	QTY
5		CAM LOCK PIN	6
6		32 x 8mm WOODEN DOWELS	5

ASSEMBLY INSTRUCTIONS FOR EXECUTIVE CORNER

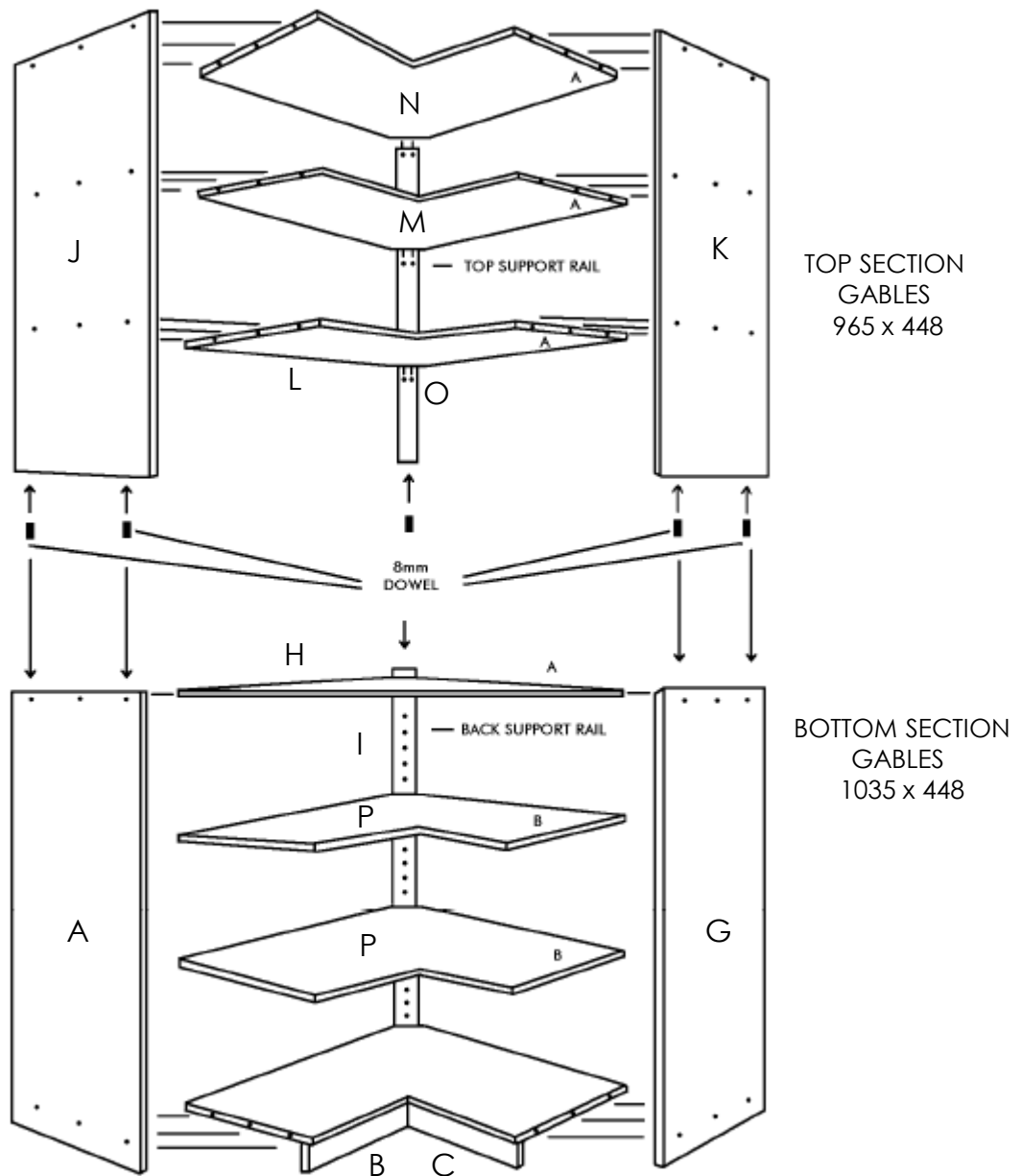

1. ASSEMBLE TOP AND BOTTOM SECTION SEPARATELY.
2. THE FIXED SHELVES ARE MARKED H,L,M & N, THE ADJUSTABLE SHELVES ARE MARKED P.
3. WHEN BOTH SECTIONS ARE ASSEMBLED, INSERT 8MM DOWELS INTO THE GABLES ON THE BOTTOM SECTION THEN CAREFULLY PLACE THE TOP SECTION ONTO THE DOWELS.
4. THE UNIT IS NOW COMPLETED TO MOVE INTO POSITION.