

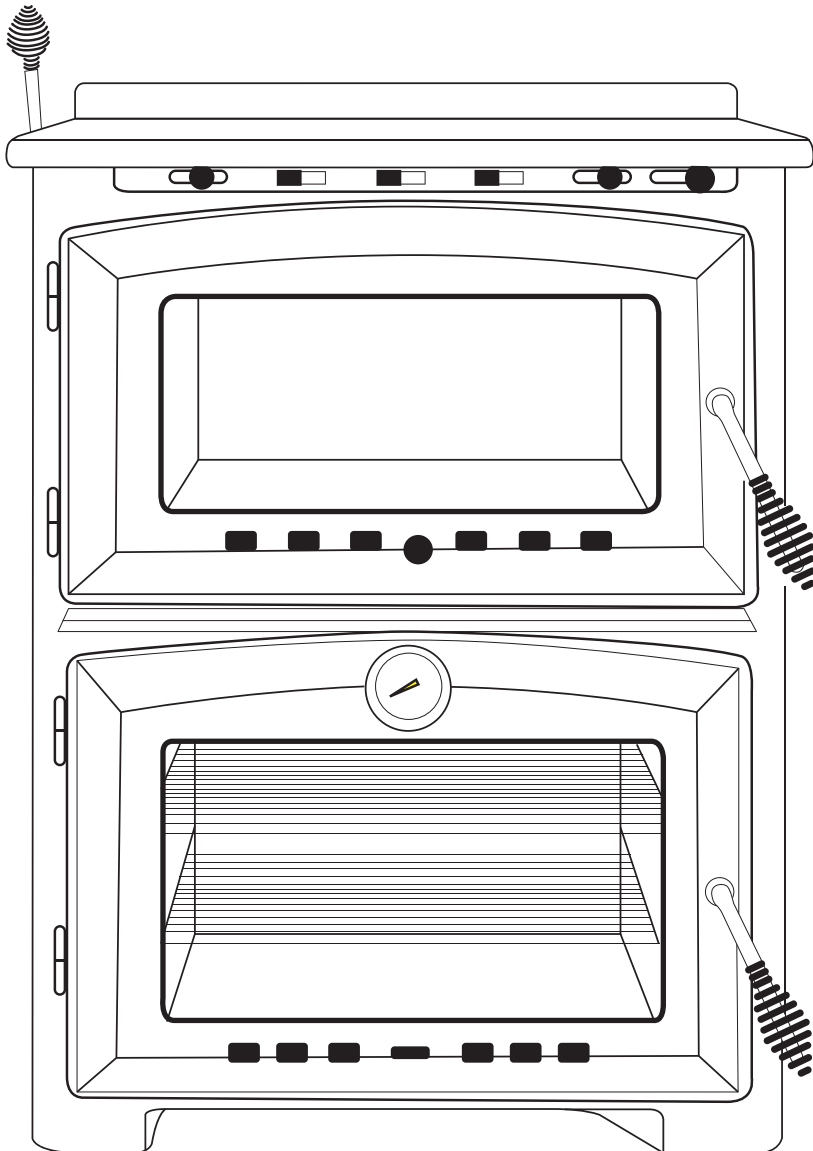

Scandia

HEAT & COOK OWNERS MANUAL



Sc.HC Version 1.3 13/11/18

Contents of manual may be updated without notice.

For the latest version of this manual please refer to our website: www.scandiastoves.com.au

Scandia Group Pty Ltd

Head Office
58 Access Way
Carrum Downs VIC 3201
Australia

+61 3 8579 5900
info@scandiastoves.com.au
www.scandiastoves.com.au

SCANDIA HEAT & COOK

Model Name	Heat & Cook
Model Number	SCX501

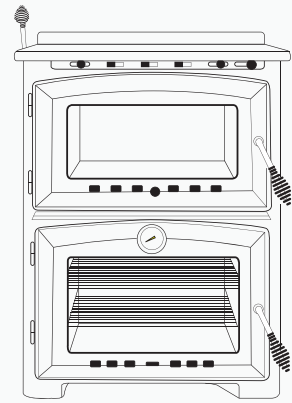

CONTENTS

Wood heater safety	2
Before installing your wood heater	3
Installation	4
Operating your wood heater	8
Wood heater maintenance	10
Trouble shooting	12
Hot water generator installation	13
Warranty	14
Spare parts list / exploded diagram	16

INTRODUCTION

Congratulations on purchasing a genuine Scandia Wood heater. When cared for properly, these high quality, finely crafted wood heaters will offer many years of reliable performance. This instruction manual has been developed to ensure optimum performance from your Scandia wood heater. It's very important that you thoroughly read and understand all instructions before using your new wood heater.

COUNCIL REQUIREMENTS

Check Local Council Requirements Eg. permits

When installing, operating and maintaining your wood heater, follow the guidelines presented in these instructions, and make them available to anyone using or servicing the wood heater.

Your city, town, state or territory may require a building permit to install a solid fuel burning appliance.

Always consult your local building inspector or local council to determine what regulations apply in your area.



Please note:

Your wood heater must be installed by a qualified person whose work conforms with local council regulations, Australian standards & manufacturers recommendations. Failure to do so will void your warranty and could possibly void any home insurance.

WOOD HEATER SAFETY

When properly maintained and operated your wood heater should give you many years of service, however there are important safety aspects of these products that you need to be aware of when operating a wood heater.

-
1. This appliance is not intended for use by persons (including children) with reduced physical, sensory or mental capabilities, or lack of experience and knowledge, unless they have been given supervision or instruction concerning use of the appliance by a person responsible for their safety.

 2. Children should be supervised to ensure that they do not play with the appliance.

 3. If the electrical supply cord is damaged, it must be replaced by the manufacturer, it's service agent or similarly qualified persons in order to avoid hazard.

 4. Never place combustible items such as but not limited to furniture, fabric or wood within the specified clearances to combustibles.

 5. The burning of wood gives off gases which can be extremely dangerous. Wood heaters are designed so that under normal operating circumstances these gases pass up the flue chimney system and cannot escape into your home, however it is important that your flue system is properly installed and that you check all joints regularly to ensure that there are no cracks or gaps, check the door sealing rope and replace when damaged/worn. We recommend a smoke alarm be fitted in rooms where wood heaters are installed. Do not use your wood heater in a room where negative pressure conditions exist. Negative pressure environments can cause products of combustion to be drawn from the fireplace into the room. Caution should be taken when using any form of extraction in a room where a wood heater is installed.

 6. This appliance is designed to specifically burn dry hardwood. Do not burn rubbish, driftwood, flammable liquids or any substance containing salts or corrosives.

 7. Creosote and soot may accumulate in your flue pipe and chimney. This may ignite, causing a chimney fire. If you suspect a chimney fire close down the air controls on the wood heater, if the fire persists evacuate people from the building and call the Fire Brigade. To prevent the accumulation of soot or creosote, check flue and chimney regularly and clean as necessary. Good burning, hot wood heaters will generally cause a lot less build-up than slow burning wood heaters, likewise dry wood will cause less build-up than wet wood. We recommend a fire extinguisher be available where wood heaters are in operation. In the event of a chimney fire do not re-light the wood heater until the heater and the flue chimney system have been thoroughly checked and repaired/replaced as necessary.

 8. Wood heaters get extremely hot and should not be touched when lit. When young children are in the area, we recommend the use of a suitable fire guard around the wood heater. Always wear protective gloves when reloading wood heater.

 9. Never over-fire your wood heater. If external parts of your wood heater are glowing red then the wood heater is over-firing and your draught settings should be reduced. Never interfere with the draught mechanisms or adjust your air settings outside those limits set when the wood heater is manufactured. Never use a secondary fan to supply or extract air to the wood heater.

 10. All users of the wood heater should be aware of the contents of this manual. Please leave this manual where it is accessible to wood heater users and do not allow anyone to use the wood heater that is unfamiliar with its correct operation.

 11. Never use the wood heater if any parts are missing or damaged, only use genuine parts as replacements. Never modify your wood heater.

BEFORE INSTALLING YOUR WOOD HEATER

You need to consider the following to ensure the safe operation of your wood heater:

- Provision of adequate air to support efficient combustion of the fuel.
- A well sealed flue/chimney system, hereinafter referred to as the "flue system".
- The protection of combustible materials in proximity of the wood heater.
- A suitable base on which to place your wood heater.

ADEQUATE PROVISION AIR

It is essential for the safe and efficient use of your wood heater that you provide an adequate air supply to your wood heater.

This may mean the provision of an outside air supply to the room, especially if there are extraction units such as cooker hoods or clothes dryers in the vicinity. Failure to do so will mean that fuel is burned inefficiently causing smoke, blackening the glass and may also cause smoke to come back into the room. As a simple check for this open a door or window in the room and check if the wood heater burns more efficiently.

WELL SEALED FLUE SYSTEM

Under no circumstances should you use aluminum or galvanized steel pipes for your wood heater flue. Always fit pipes with the narrow crimped side down, this allows any creosote to run down the inside of the pipe and not to come out and cause an unsightly mess and possible fire hazard.

Pipe bends should be kept to a minimum and we do not recommend using more than 2 bends on any installation. Flues must not pass through ceilings, floors, attics, roofs, or combustible walls without adequate and approved insulation being provided to protect combustible materials.

The chimney and flue provide a means of taking combusted fuel from the wood heater, as well as a draught to enable the wood heater to work. It is essential that the flue system is kept in good condition and there are no breaks or cracks allowing contact with any other combustible materials of the house. It is also essential that the flue system is kept clean and seals are maintained to ensure the draught is not lost.

The open end of the flue system must be above the height of the apex of the building and any other obstructions, such as trees, which are within 3 meters (10ft) of the flue system. Failure to do this will affect the efficiency of the wood heater and may cause down draughts which will mean dangerous products of combustion are emitted into the room.

Under no circumstances should the flue pipe be less than 6" (152mm) internal diameter.

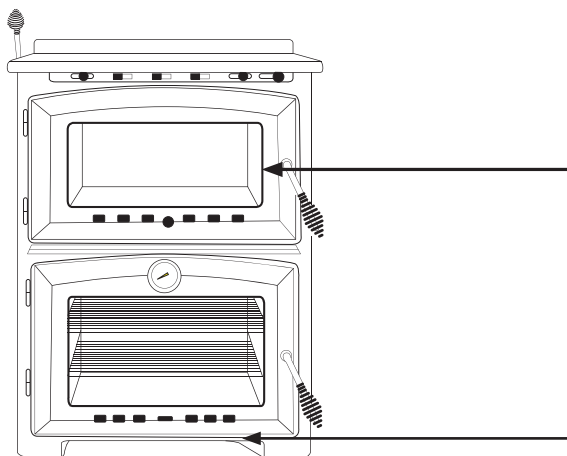

PLEASE NOTE

Firebox liners are a consumable item and may warp during use.

(See maintenance guide P:10 for details)

When unpacking, please remove the cleaning brush located in the flue collar.

Hot Plates can be found in Lower Ash Tray

BEFORE INSTALLING YOUR WOOD HEATERcontinued

CLEARANCES TO COMBUSTIBLES

It is extremely important that you respect required installation distances and that you respect local installation regulations. This is for your safety! The manufacturer is not responsible for the product, if it is not installed following these recommendations. These clearances may only be reduced by means approved by the regulatory authority. A combustible surface is anything that can burn (i.e. plaster, wall paper, wood, fabrics etc.) These surfaces are not limited to those that are visible and also include materials that are behind non-combustible materials. If you are not sure of the combustible nature of a material, consult your local fire officials.

HEARTH REQUIREMENTS

The floor protector must consist of 30mm thick cement fibre sheet which has a thermal resistance of 0.008m² K/W, per 4mm thickness or equivalent. Scandia have a complete range of suitable ready to install hearth pads for straight wall and corner installations.

INSTALLATION

CLEARANCES TO COMBUSTIBLES

A	Side of heater to side wall	425
B	Centre of heater flue to rear wall	295
C	Rear of heater to rear wall	175
D	Front of heater to hearth front	300
E	Minimum hearth width	820
F	Minimum hearth depth	1040
G	Rear corner of heater to wall	200
H	Minimum Corner Hearth Depth	1250

All measurements are in 'mm'

When using either Scandia decorative mesh or sleek black flue kit which are both fitted with an additional heat shield.

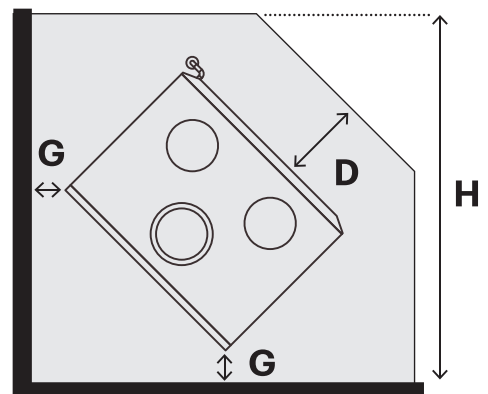
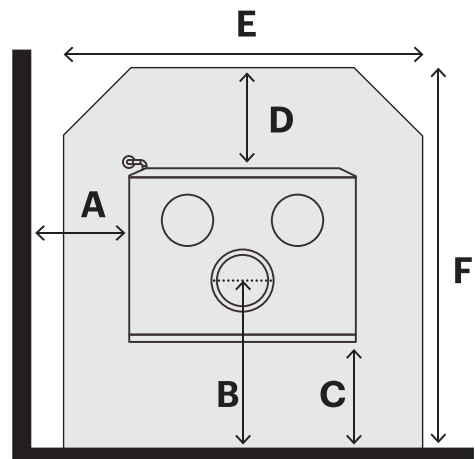

Manufacturers recommendation: Keep all combustible materials at least 1.22 metres (4 feet) away from the appliance. This include rugs, fabrics, furnishings, papers, firewood, etc. NEVER dry clothing on or within 1.22 metres of the appliance.

INSTALLATIONcontinued

FOR CONNECTING INTO A STANDARD INSTALLATION USING SCANDIA FLUE KITS

The following drawing is meant as a guide only. Your wood heater must be installed by a qualified person whose work conforms with local council regulations, Australian/New Zealand standards (AS/NZS 2918:2018) & manufacturers recommendations.

Scandia wood heaters are independently tested to Australian Standards using a Scandia flue kit, we always recommend using a Scandia flue kit when installing a Scandia wood fire.

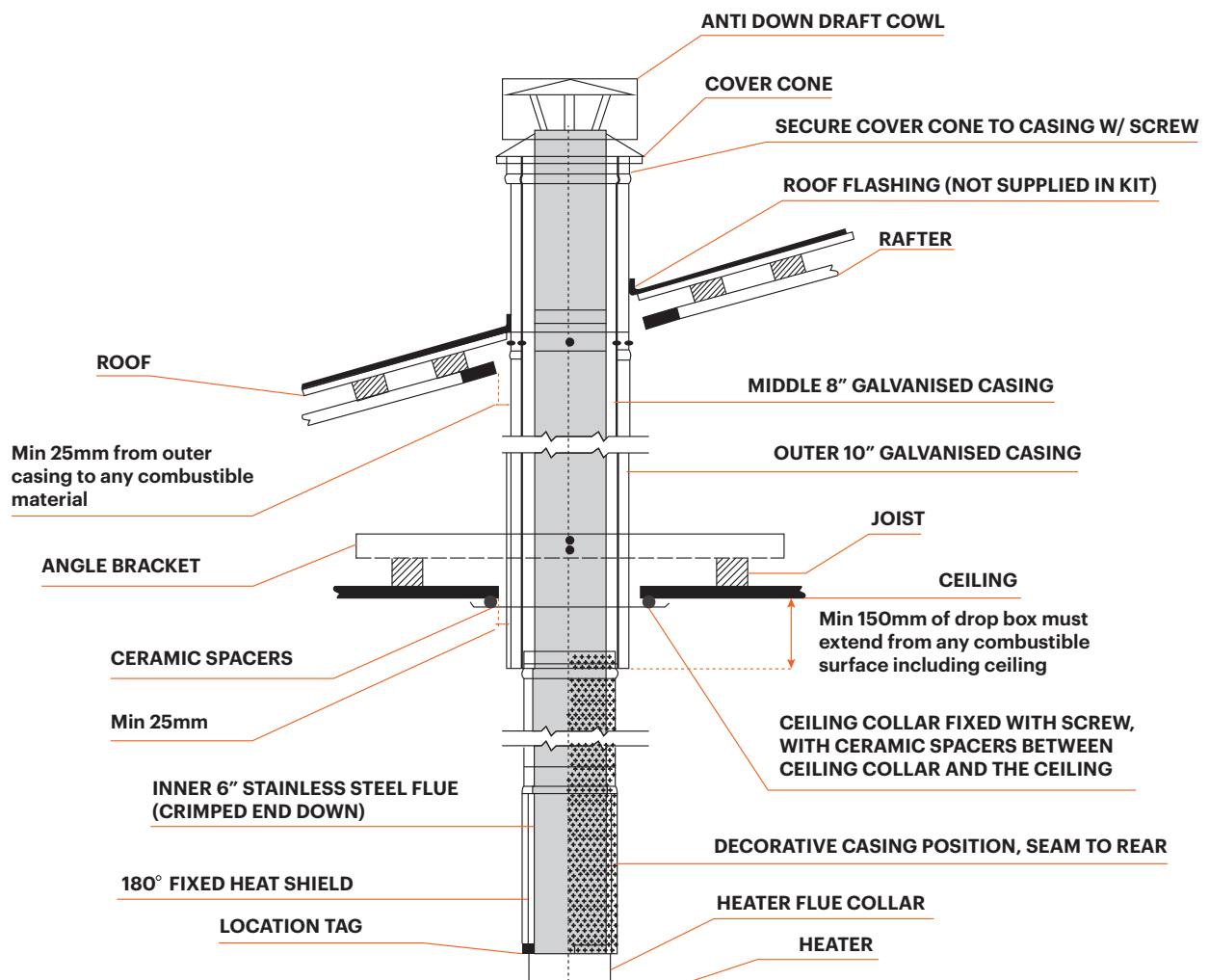

1. Locate wood fire in it's proposed position according to manufacturers recommendations.
2. Use a plumb bob to mark the ceiling in line with the centre of the flue collar.
3. Check that the outer casing will clear all combustible materials by 25mm. Determine positions of noggins to avoid cutting, otherwise headers must be installed for strength.
4. Cut a 305mm diameter hole in the ceiling. Directly above cut a hole in the roof to accommodate outer casing.
5. Fix the angle brackets to the joists so that the drop box (first length of located casing) is located in the centre of the hole.

INSTALLATIONcontinued

6. Position the drop box between the angle brackets, keeping a 25mm clearance to combustibles. The located end of the drop box must protrude no less than 150mm down from the ceiling or any combustible material. Fix the drop box to the angle brackets.
7. Add the remaining casings to the required height. Australian/New Zealand Standards state that "the flue pipe shall extend not less than 4.6m above the top of the floor protector". If the flue pipe is within 3 metres of the ridge, the flue pipe must protrude at least 600mm above the ridge of the roof. If the distance from the ridge is more than 3 metres, the flue pipe must protrude at least 1000mm above roof penetration. Additional lengths of casing and flue may be required to achieve this. The flue pipe must be more than 6 metres from any nearby structure. Other clearances may be applicable, it is up to the installer to ensure compliance with all regulations. **See Figure 1 and 2 on P7.**
8. Install roof flashing (Additional accessory, not supplied in flue kit)
9. Secure the Ceiling Collar in place using ceramic spacers and screws provided.
10. Insert crimped end of the upper decorative flue (without internal stainless steel heat shield) up into the drop box. Then insert the crimped end of the lower decorative flue (with the internal stainless steel heat shield) up into bottom of the upper decorative flue. The lower decorative flue features locating tags on the non crimped end which rest on the heater flue collar. The solid heat shield section of the decorative mesh and stainless steel inner heat shield is to face the wall.
11. Feed stainless steel flue through decorative flue and drop box through to the required height. Assemble flue pipes tight together as you go ensuring seams are straight. Secure each joint with three stainless steel rivets or screws spaced equally. Clean any finger prints or oils off stainless steel flue with methylated spirits.
12. Trim the inner flue to the same height as the outer casing. Place cover cone and cowl over stainless steel flue & push cover cone over gal casing. Fix cover cone to gal casing with stainless steel pop rivets or screws.

FOR CONNECTING INTO EXISTING MASONRY CHIMNEY

Any chimney should be fully intact with no holes or missing bricks. We recommend a chimney register be installed above any installation into a masonry fireplace minimising heat loss up the chimney. The top of the chimney must be sealed using a chimney plate which should be sealed in place with a mortar mix.

Active flue should be trimmed in line with the top of the chimney if it meets the minimum height requirements under AS/ NZS 2918. If additional lengths are required to fulfill this requirement these lengths must be cased. The flue should always be finished with a cowl and cone.

MINIMUM INSTALLATION CLEARANCES

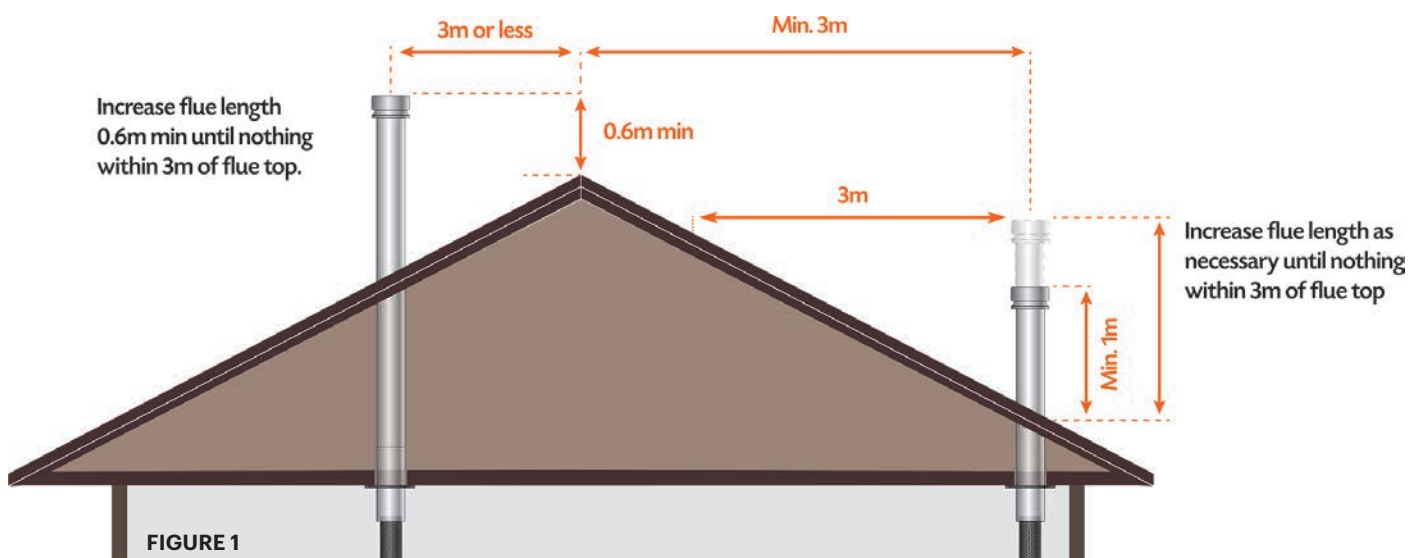

MINIMUM INSTALLATION CLEARANCES

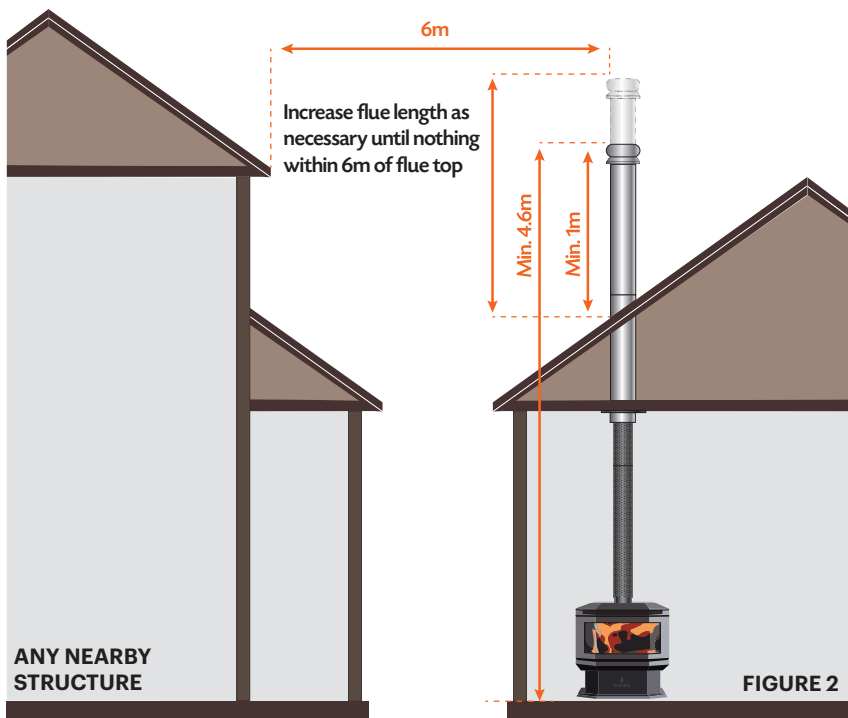

SEISMIC RESTRAINT OF HEAT AND COOK

NEW ZEALAND REQUIREMENT

In order to comply with standard AS/NZS2918:2018, it is required that the wood fire and floor protector be secured to prevent shifting in the event of an earthquake. Anchor the appliance to the floor through the holes in the base (foot) of the appliance.

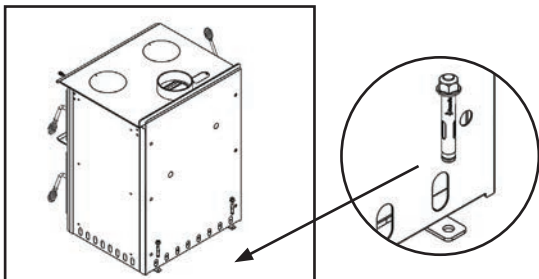

STEP 1

Seismic restraint hole locations protrude from the base of the Heat and Cook at rear and front of the unit.

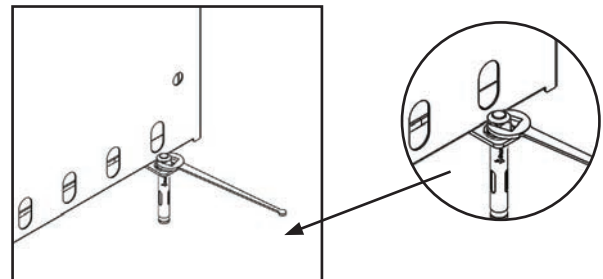

STEP 2

Tighten nut with ring spanner or ratchet to a firm holding tension.
Repeat for all four bolts.

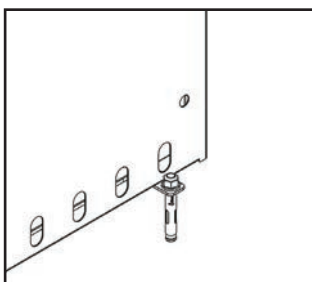

STEP 3

When all four bolts are secured to assigned tension the unit is restrained for seismic motion.

OPERATING YOUR WOOD HEATER

CONTROLS AND THEIR USE

1.	Flue Damper	Aids in lighting fire. Back = Open. Forward = Closed.
2.	Primary Air Inlet Control	Provides primary air intake to regulate burn rate of fire and keep glass clean.
3.	Secondary Air Inlet Control	Provides secondary air intake directly to coal base to further regulate burn rate of fire.
4.	Oven Temperature Control	Provides cool air to oven to further regulate oven temperature. (Burn rate of fire will be the main temperature regulation).

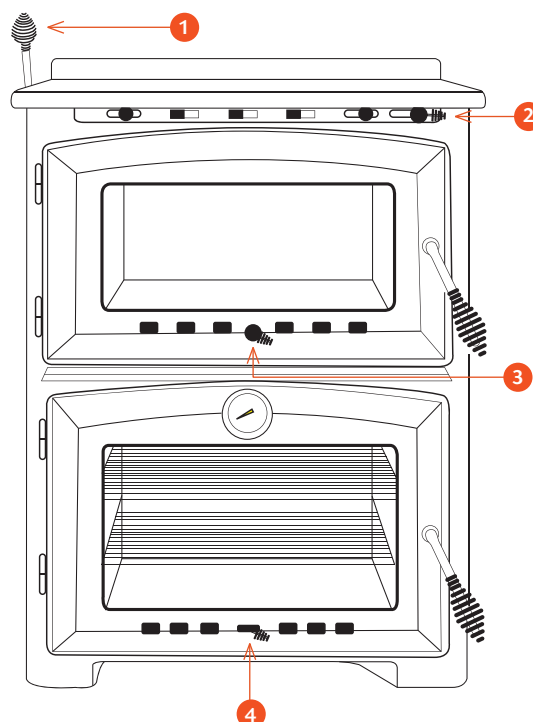

FUEL

Your wood heater is designed to burn dry hardwood only.

It is **NOT** designed to burn the following:

- Treated or painted wood
- Paper or cardboard, other than small amounts used to light stove.
- Plastics
- Synthetic fuel or logs that are not approved
- Household rubbish
- Liquid fuels

Burning these or other products for which the wood heater was not designed may damage the wood heater and cause a fire hazard or release toxic fumes.

Fuel should be stored in a dry place; wood should be dried for at least 1 year and have a moisture content of less than 20%. Wet wood may cause serious creosote build up, which may damage your flue system and even your wood heater. Therefore the use of green, sappy or wet wood is strongly discouraged.

RECOMMENDED FUEL TYPES

When used in the following locations the fuel type recommendation is:

- NEW ZEALAND** Recommended fuel type is Softwood
AUSTRALIA Recommended fuel type is Hardwood.



WARNING: FIRST OPERATION OF STOVE

When operating, this unit will get extremely hot. Do Not Touch, use tools where necessary. You should begin using your wood heater by lighting small fires which get progressively larger. We recommend lighting approximately 5 small fires before you put the wood heater into full service. Allow the wood heater to fully cool between each of these fires. There may be some smell and a small amount of smoke from the wood heater during the initial operations. This is perfectly normal and is merely the curing of the wood heater paint. Opening a window or door to provide additional ventilation will help alleviate this.

OPERATING YOUR WOOD HEATERcontinued

AIR CONTROLS

Your wood heater needs air to burn the fuel, on this range this is supplied in two locations. The primary air slide at the right side of the front of your wood heater above the door and the secondary air slide at the bottom of the firebox door.

Primary air, as the name suggests, is used for the initial burning of the fuel and is also used to keep the stove glass clean. Secondary air is used for secondary combustion, which makes the stove more efficient, reduces the emissions by introducing air directly over the fire bed.

The settings of the primary and secondary air control very much depends on draught and local conditions and after a few fires, you should have a good idea of the best settings for your stove. Both air slide controls should be fully opened when lighting the fire. Once the fire is established, the primary air can be adjusted to where the glass remains clean and the secondary air control may be adjusted as required. Reducing the air intake will cause the wood heater to burn slower. This may cause some blackening of the stove glass, but this should burn off once the wood heater is burning brightly again.

The flue damper must be kept closed except when lighting the fire. If oven is too hot for cooking lower temperature quickly by opening the oven temperature control and the flue damper until required heat is reached and then close. Adjust air controls so temperature is maintained. Keep the firebox door closed securely at all times except when de-ashing the fire or reloading wood.

Keep all combustible materials at least 1.22 metres (4 feet) away from the appliance. They include rugs, fabrics, furnishings, papers, firewood, etc. NEVER dry clothing on or within 1.22 metres of the appliance.

LIGHTING THE FIRE

Open the fire door, lay a few crumpled sheets of paper on the firebox base then a few small dry pieces of sticks or kindling. Open the flue damper fully by pushing backwards. Open both the air inlet controls. Now light the paper, close the fire door when the kindling has caught fire (allow about 10 minutes for this to happen) add larger pieces of dry wood, until the fire box is half filled. When the larger pieces of wood have caught fire, add full sized logs, close the flue damper. Close the air controls to the point where the required burn rate is obtained.

REFUELING

Before refueling your wood heater, turn the air supply to high for a few moments until there is a good fire in the heater. This will ensure there is no build-up of harmful gases in the wood heater when the door is opened and will also get the new fuel burning quickly and not allow it to kill the fire. Open the door slowly in case any logs or coal have fallen against the glass. Opening the door quickly may result in smoke being drawn into the room.

To reload the wood heater, open the door and feed the fuel in slowly always using either tongs, a small shovel along with protective gloves. Do not overfill the wood heater. It is always better to put in small loads often rather than big fills less frequently. Wood should be loaded in a front to back direction, this helps air flow as well as reducing the risk of logs falling forward. Close the door gently after wood heater is reloaded.

OVERNIGHT BURNING

Your wood heater is designed to maximise burn times. Best results are achieved when you establish a good fuel bed in the wood heater and allow it to burn for about 30 minutes before closing the air slide control fully.

When you return to your wood heater, fully open the air slide control until you have a good fire and then set to normal operating levels. Do not add fuel until the fire bed is hot and red. Then add a little for the first time and allow that to ignite before adding more. During overnight burning, the wood heater glass may blacken, but when a hot fire is established again this should burn off.

WOOD HEATER MAINTENANCE

CHECK YOUR WOOD HEATER REGULARLY

Initially, we recommend you check your flue system at least once per month. After the first few months you will notice a pattern of soot and creosote build up and you can then determine an inspection interval for checking soot and creosote build up that is suitable for your wood heater installation.

Other checks, as listed below, should be carried out at least twice per year. If you notice anything wrong at any time it should be repaired immediately. Never use a wood heater that is in any way damaged or has a damaged flue.

-
1. Check your flue system and the void between the firebox and the outer skin of the unit for build up of soot or creosote and for signs of damage to joints.

 2. To inspect the area between the firebox and the outer skin remove the hotplate and inspection plates located on the top and front of each unit. Using a flashlight to inspect and the wire brush provided to remove any built-up residue.

 3. On occasion during normal use and immediately after cleaning remove bottom ash pan, empty, clean and re-position.

 4. During periods in inactivity or infrequent use, regularly alternate the position of the flue damper. We also recommend placing a silica bag in the firebox to absorb any moisture which may cause rust.

 5. The Heat & Cook firebox is lined with steel firebox liners, these are designed to expand and contract which will warp to some degree during use, this is normal. Replacement of the liners should be undertaken when any section of the liners is less than 1mm thick or any holes appear.

CLEANING INSTRUCTIONS



WARNING

Before beginning to clean your stove make sure the unit is not in use and is cold.

It is advised that you put some plastic down on the floor in front of the stove whilst cleaning to prevent any creosote or ash from falling on the floor.

-
- STEP 1.** Remove rear cleaning port cover located on the top plate to the left hand side. Push the cleaning tool down the back of the stove moving it about to loosen any built up creosote or ash. These loose particles will fall to the bottom into the ash drawer.
-
- STEP 2.** Remove hot plate and push cleaning tool down each side of the outside of the fire box past the oven, move cleaning tool about to loosen any built up creosote or ash. These loose particles will fall to the bottom of the stove.
-
- STEP 3.** Open the oven door and remove the ash drawer and dispose of ash carefully. Make sure the ash/creosote is cold. If the stove was particularly full of creosote once the ash drawer is removed additional creosote may fall into the compartment. Scrape this out also. Make sure sides and back are clear before putting stove back into service.

WOOD HEATER MAINTENANCEcontinued

ASH REMOVAL

When the stove is out and completely cold you may remove the ash using an ash vacuum or a steel bucket with a lid and shovel. Place a cover over the bucket so that when removing the bucket the ash does not blow about your house.

HOT WATER GENERATOR (OPTIONAL)

According to Australian law this appliance must be installed by a registered plumber. Be sure to always have water running through your system, failure to do so will result in damage to hot water generator. When installing the plumber must use radial bends and always have the hot water line from the hot water generator to the storage unit inclining. Failure to comply with any of the above will negate warranty.

WARNING: DO NOT CAP OFF HOT WATER OUTLETS!

CARE OF GLASS

At times, especially when the air controls are turned to low settings or when damp wood is used, the wood heater glass will blacken. This is caused by fuel that is not completely burnt, but the build-up on the inside of the glass will normally burn off when a good hot fire is established in the wood heater.

There may be times however when you need to clean the glass. To do this, use a soft cloth and a non-abrasive glass cleaner.

Only ever clean the glass when the wood heater is cold. For best results select from Scandia's range of glass cleaning products.

When loading fuel into the wood heater, always make sure it is not protruding out through the door opening, as this may break the glass when you close the door. This is especially relevant when loading logs. Always close the door gently.

If the glass does crack when the wood heater is lit, let the fire die out. Do not open the door until the wood heater has fully cooled. Replace the glass with the specified replacement part before re-using the wood heater.

DOOR ADJUSTMENTS

Door closing tension adjustment - As door seals age the seal beds into the heater body, this will allow air to be drawn in any gaps created. Remove the grub screw from the door handle shaft on the inside of the door, this will allow the handle to rotate 360°. Rotate the handle 1 full turn anti-clockwise and shut the door. Repeat this step until the door offers a little resistance to close. Replace the grub screw. Over tightening may cause the door to distort and break the glass. If the door is at maximum adjustment this generally means the door seal will need replacing.

SURFACE FINISH

To clean your heater wipe lightly with a damp cloth or dust with a duster. Some cleaning products may leave stains on the wood heater surface. Never use abrasive cloths as these may scratch the surface; take caution when using microfiber cloths as they can leave swirl marks if used in a circular motion. Painted wood heaters can be re-painted by using a good quality, high temperature wood heater paint. When re-painting, make sure there is plenty of ventilation and follow the manufacturer's instructions. Allow the paint to fully dry before lighting the stove and allow extra ventilation for the first couple of fires as some fumes may emit from the stove as the paint cures.

Scandia high temp enamel is available at your local Scandia retailer.

Visit www.scandiastoves.com.au for details.

REPLACING PARTS

Always use genuine replacement parts. Only ever make replacements when the wood heater is cold.

All replacement parts can be ordered from www.scandiastoves.com.au.

TROUBLE SHOOTING

Many people underestimate the importance of using a professional installer with experience in wood heating who adheres to Australian Standards to install their wood fire.

If you are having issues with your wood fire not working the way you think it should, we implore you to speak to your installer first; they can help you with issues such as burning too much or too little wood, smoke in the room when you open the door, blackened glass or build-up of creosote during use. A professional installer can also provide guidance on whether the problem is a manufacturing issue in this instance we will work with them to resolve any issues as soon as possible for you.

It is important to remember that all flue installations must be compliant with Australian Standards. A heater installed with a non-compliant flue configuration will not perform as advertised or as tested.

FIRE NOT BURNING

A wood heater not burning is generally caused by either a shortage of air and/or incorrect or damp fuel. If fuel is not the problem check:

-
1. That the air controls are opened.

 2. There is no blockage in the flue system.

 3. That the open end of the flue is above the height of any nearby obstructions.

 4. That there is a sufficient air supply into the room and that this supply is not being taken by an extractor fan.

GLASS BLACKENS

Glass usually blackens when:

-
1. The fuel is not being burned efficiently because of starvation of air.

 2. Bad quality or damp fuel is being used.

Please note: For optimum efficiency always use a good quality dry hardwood.

FIRE BURNING TOO QUICKLY

This is usually caused by too much draught or air.

-
1. Firstly try reducing the air supply to the wood heater by closing down your air controls, if this fails then you may have to adjust the door or you may have damage to the sealing.

 2. Close a thin strip of paper in the door, check to see if the paper stays in place or pulls out. If the paper pulls out easily you may need to adjust or replace the door seal.

 3. Check to see if the glass moves within the door frame. If it does you may need to tighten the glass retainer screws.

 4. Check the condition of the door sealing rope and the glass seal tape.



See video at:
https://www.youtube.com/watch?v=nT-V_zL4jeg

CHIMNEY FIRE

Chimney fires occur when soot and creosote that have built up in the flue system ignite. If the wood heater is operated properly and the flue checked and cleaned regularly then chimney fires should not occur. These fires can be very dangerous and must be avoided. Try to maintain good, hot fires in the wood heater whenever possible and at least once in every firing open the air controls and allow the wood heater to burn on full for a short while until the entire fire bed is glowing red.

Check your flue system regularly for build-up of soot and creosote and clean as necessary. Chimney fires can be detected by sparks coming from the top of the chimney, a roaring sound coming from the area of the stove or chimney or vibration in the stove or chimney. In the event of a chimney fire, close the air controls, evacuate the building and call the fire department. Do not relight the stove after a chimney fire until the stove and flue have been checked and any necessary repairs have been carried out.

SMOKE IN ROOM

If the wood heater is properly installed it should not emit any smoke into your room. Should this happen, check that your room is not air tight. This can easily be checked by opening a door or window. If the smoking stops you need to provide an additional air supply into the room. If this is not the problem, check if your chimney is blocked or obstructed and that you are not getting a down draught caused by the location of the open end of the flue pipe or chimney.

If the problem persists contact your installation company and ask them to get your chimney and stove installation checked.

SCANDIA HEAT & COOK HOT WATER GENERATOR INSTALLATION INSTRUCTIONS

PART NO. SCX520 - SCANDIA HEAT & COOK HOT WATER JACKET

1. Remove fire brick retaining bar.
2. Remove firebox side liners.
3. Remove fire bricks.
4. Remove rear panel of stove and remove pipe exit hole covers.
5. Remove inner rear panel of stove and remove pipe exit hole covers.
6. Remove insulation.
7. Remove pipe exit hole covers from rear side of firebox.
8. Remove nuts from hot water generator pipes.
9. Install hot water generator in firebox, pipes first. The pipes should line up with exit holes in the back of firebox. Push hot water generator pipes all the way through the exit holes until the rear face of the hot water generator touches the rear of the firebox.
10. Put one nut on each of the pipes extruding from the rear of the fire box. Nuts are not required to be very tight, just enough pressure is required to hold hot water generator in place. Do not over tighten as you may damage hot water generator.
11. Replace firebrick retaining bar then side liners.
12. Replace insulation.
13. Replace inner rear panel.
14. Replace outer rear panel.

Now the stove is ready to be connected to the house water system. Please make sure an experienced plumber connects stove to a low pressure open vented system only. The hot water line from stove must always incline and radial bends must be used. Make sure the storage unit being used is compatible with a combustion stove. Pipe exit hole covers and fire bricks are no longer required.

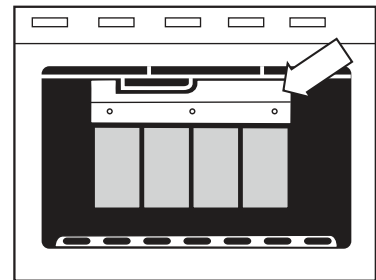

Firebrick retaining bar

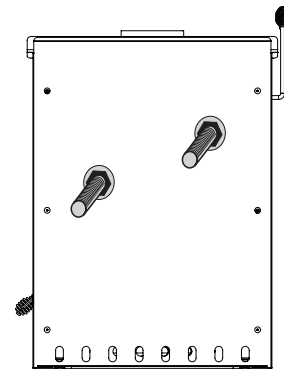

Pipes extruding rear of firebox

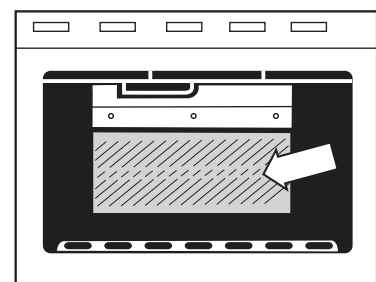

Hot water generator in position

WARRANTY

SCANDIA LIMITED WARRANTY

This limited warranty is given by Scandia Heating (Aust) Pty Ltd (ACN 005 868 093) (Scandia or we) to the original retail purchaser (you) of the wood heater to which this Warranty applies.

Our goods come with guarantees that cannot be excluded under the Australian Consumer Law. You are entitled to a replacement or refund for a major failure and for compensation for any other reasonably foreseeable loss or damage. You are also entitled to have the goods repaired or replaced if the goods fail to be of acceptable quality and the failure does not amount to a major failure.

The benefits that this Warranty provides are in addition to other rights and remedies available to you under the Australian Consumer Law. This Warranty does not limit those rights and remedies.

SCOPE OF WARRANTY

If a defect in material or workmanship appears in the following parts within the corresponding warranty period after the date of the original purchase, such as to make the wood heater unfit for normal home use; and you comply with the requirements below regarding making a claim, then, subject to the exclusions below, we will replace or repair the relevant part or (at our option) replace the entire wood heater with the same or comparable model.

PART	WARRANTY PERIOD
Firebox	10 Years
All other parts (Including dampers, liners and firebrick retainers)	1 Year

To the extent permitted by law, our liability under this Warranty is limited to this replacement or repair obligation.



IMPORTANT

For this Warranty to apply, you must fully complete the Warranty Registration Form via scandiaheating.com.au/warranty. Alternatively you can complete the Warranty Registration Card and mail it to our mail address (below) within 30 days after the original purchase. By completing this form, you also agree that, to the extent permitted by law, our liability to you on any basis in relation to the wood heater (other than under the Australian Consumer Law) is limited to our obligations under this Warranty.

WARRANTYcontinued

EXCLUSIONS

This Warranty does not apply:

1. Where the defect is not due to the original design or manufacture of the part (including where the wood heater, part or accessory has been subject to accident, abuse, alteration, misuse or neglect or has been installed, inspected, operated or maintained negligently or not in accordance with applicable local laws and regulations and the manufacturer's printed instructions, if any)
2. Where the firebricks, top baffle or fibreglass seal have not been replaced after becoming damaged or worn
3. To any accessories or optional parts
4. To any glass, paint, firebrick, fibreglass seal sold or used with the wood heater
5. To any surface rust which may occur in transit, storage or use.
This includes installations in close proximity to coastal areas and salt water which may cause rust to the appliance.

HOW TO MAKE A CLAIM

Any claim under this Warranty must be in writing to our mail address below. It must be sent within the applicable warranty period and must state:

1. The model and serial number of the wood heater
2. The place, price and date of purchase
3. Reasonable details of the defect

To obtain replacement or repair under this Warranty, the wood heater must be returned to the original place of purchase (and collected from there once the replacement or repair is complete) at your cost. Scandia will not be responsible for any associated freight, disconnection or re-installation costs (including labour costs). Scandia will only be responsible for transport of the wood heater from the original place of purchase to Scandia's premises (and back), and replacement or repair in accordance with this Warranty.

REGISTER YOUR PRODUCT



REGISTER ONLINE

Register your product warranty online by visiting:
www.scandiastones.com.au/warranty

Your data will be used by Scandia to provide you with information about your purchase upon request.



REGISTER BY MAIL

Alternatively, please complete the attached warranty card within 30 days of installation and return to:

Scandia Group Pty Ltd.
58 Access Way, Carrum Downs
Victoria, Australia, 3201.

HEAT & COOK SPARE PARTS LIST

LEGEND	PART	QTY	SCANDIA PART NO.
1	Heat n cook body	1	SP50101
2	Fire box door	1	SP50102
3	Fire box door glass	1	SP50103
4	Door air slide	2	SP50104
5	Door air slide retainer	6	SP50105
6	Glass retainer, fire box door	2	SP50106
7	Oven door	1	SP50107
8	Oven door glass	1	SP50108
9	Thermometer	1	SP50109
10	Glass retainer, oven door	2	SP50110
11	Smoke deflector box	1	SP50111
12	Rear heat shield, external	1	SP50112
13	Heat n cook primary air slide	1	SP50113
14	Flue damper rod	1	SP50114
15	Firebox liner, right side	1	SP50115
16	Firebox liner, left side	1	SP50116
17	Air slide spring handle	3	SP50117
18	Smoke deflect box control handle spring	1	SP50118
19	Ash pan	1	SP50119
20	Oven rack	2	SP50120
21	Hot plate	2	SP50121
22	Flue damper plate	1	SP50122
23	Left side panel	1	SP50123
24	Right side panel	1	SP50124
25	Water jacket blocking plate	6	SP50125
26	Oven heat deflector	1	SP50126
27	Brick retainer	1	SP50127
28	Door handle spring	2	SP50128
29	Door handle rod	2	SP50129
30	Heater bottom plate	1	SP50130
31	Air slide plate retainer	2	SP50131
32	Air slide plate spring	2	SP50132
33	Ash clean slot cover	3	SP50133
34	Door latch	2	SP50134
35	Firebrick 1	2	SP50135
36	Inner rear heat shield	1	SP50136
37	Firebrick 2	2	SP50137
38	Door hinge male	4	SP50138
39	Door hinge female	4	SP50139
40	Side insulation blanket	2	SP50140
41	Rear insulation blanket	1	SP50141
42	Utility hook	1	SP50142
43	Cleaning brush	1	SP50143

HEAT & COOK EXPLODED DIAGRAM

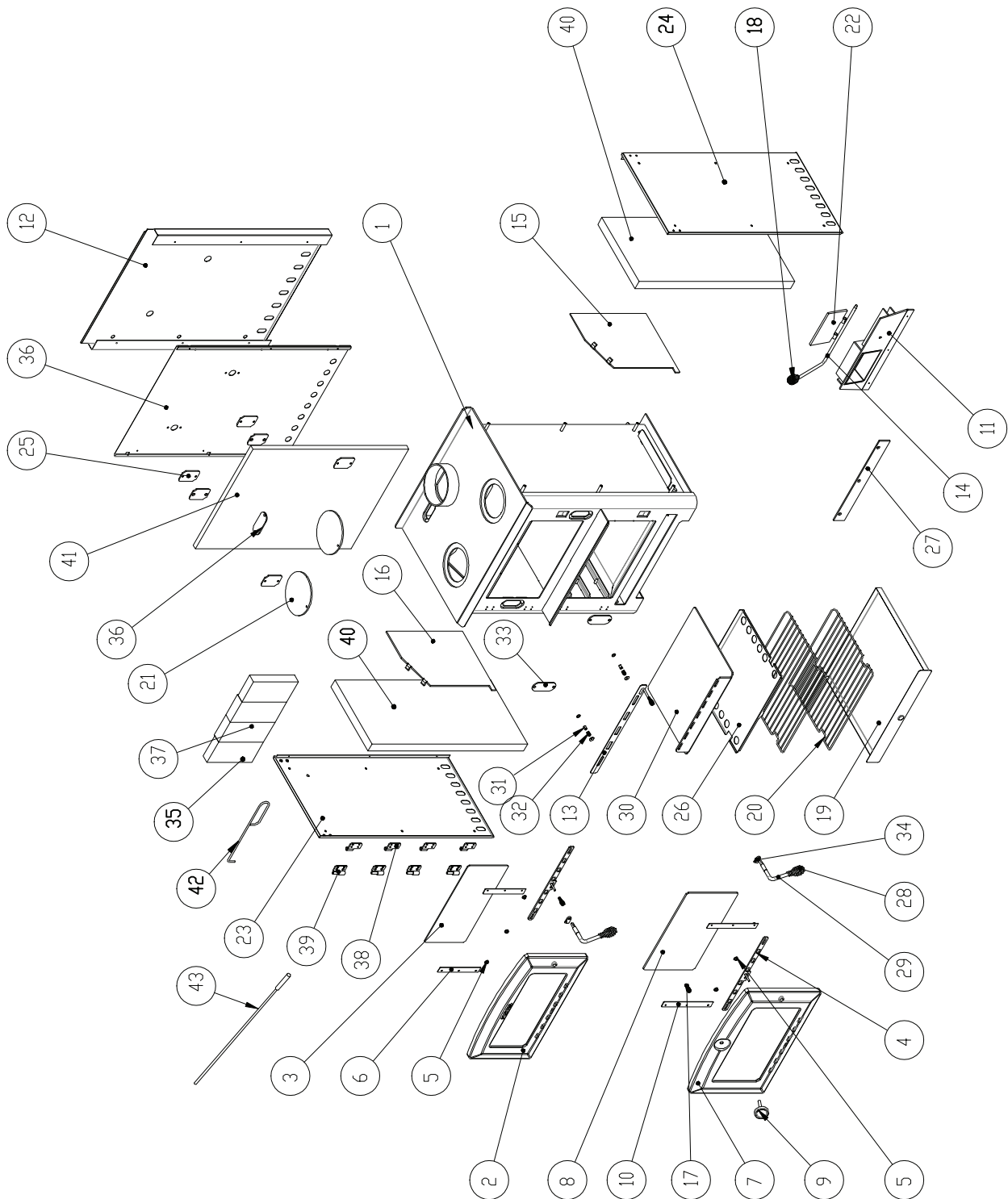

Head Office
 58 Access Way
 Carrum Downs VIC 3201
 Australia

Scandia Group Pty Ltd
 (03) 8579 5900
 info@scandiastoves.com.au
 www.scandiastoves.com.au



