



ITEM : 0094876  
MODEL : PBV3P1  
PART : 77353



SGS-150374-E

# PBV3P1

## VERTICAL WOOD PELLET SMOKER (3-SERIES)

IMPORTANT, READ CAREFULLY, RETAIN FOR FUTURE REFERENCE. MANUAL MUST BE READ BEFORE OPERATING!

FOR OUTDOOR USE ONLY. NOT FOR COMMERCIAL USE.



### ASSEMBLY AND OPERATION INSTRUCTIONS

WARNING: Please read the entire manual before installation and use of this electric, pellet fuel burning appliance. Failure to follow these instructions could result in property damage, bodily injury or even death. Contact local building or fire officials about restrictions and installation inspection requirements in your area.

**RECIPES INCLUDED  
IN BACK OF MANUAL**

# SAFETY INFORMATION

**MAJOR CAUSES OF APPLIANCE FIRES ARE A RESULT OF POOR MAINTENANCE AND A FAILURE TO MAINTAIN REQUIRED CLEARANCE TO COMBUSTIBLE MATERIALS. IT IS OF UTMOST IMPORTANCE THAT THIS PRODUCT BE USED ONLY IN ACCORDANCE TO THE FOLLOWING INSTRUCTIONS.**

Please read and understand this entire manual before attempting to assemble, operate or install the product. This will ensure you receive the most enjoyable and trouble-free operation of your new wood pellet grill. We also advise you retain this manual for future reference.

## DANGERS AND WARNINGS

**You must contact your local home association, building or fire officials, or authority having jurisdiction, to obtain the necessary permits, mission or information on any installation restrictions, such as any grill being installed on a combustible surface, inspection requirements or even ability to use, in your area.**

1. A minimum clearance of 305mm (12 inches) from combustible constructions to the sides of the grill, and 305mm (12 inches) from the back of the grill to combustible constructions must be maintained. **Do not install appliance on combustible floors, or floors protected with combustible surfaces unless proper permits and permissions are obtained by authorities having jurisdiction.** Do not use this appliance indoors or in an enclosed, unventilated area. This wood pellet appliance must not be placed under overhead combustible ceiling or overhang. Keep your grill in an area clear and free from combustible materials, gasoline and other flammable vapors and liquids.

**Should a grease fire occur, turn the grill OFF and leave the lid closed until the fire is out. Unplug the power cord from the connected outlet. Do not throw water on the unit. Do not try to smother the fire. Use of an all-class (class ABC) approved fire extinguisher is valuable to keep on site. If an uncontrolled fire does occur, call the Fire Department.**

2. Keep electrical supply cords and the fuel away from heated surfaces. Do not use your grill in the rain or around any water source.
3. After a period of storage, or non-use, check the burn grate for obstructions, the hopper for foreign objects, and any air blockage around the fan intake, chimney, or rear barrel exhaust holes. Clean before use. Regular care and maintenance is required to prolong the lifespan of your unit. **If the grill is stored outside during the rainy season or seasons of high humidity, care should be taken to insure that water does not get into the hopper.** When wet or exposed to high humidity, wood pellets will expand greatly, decompose, and may jam the feed system. Always disconnect the power, before performing any service or maintenance.

**Do not transport your grill while in use or while the grill is hot. Ensure the fire is completely out and that the grill is completely cool to the touch before moving.**

4. It is recommended to use heat-resistant barbecue mitts or gloves when operating the grill. Do not use accessories not specified for use with this appliance. Do not put a barbecue cover or anything flammable in the storage space area under the barbecue.
5. To prevent fingers, clothing or other objects from coming in contact with the auger feed system, the appliance is equipped with a metal safety screen, mounted to the interior of the hopper. This screen must not be removed unless directed by Customer Service or an authorized dealer.

**This appliance is not recommended for children, persons with reduced physical, sensory or mental capabilities, or lack of experience and knowledge, unless they are under direct supervision or instruction by a person responsible for their safety.**

6. Parts of the barbecue may be very hot and serious injury may occur. Keep young children and pets away while in use.
7. Do not enlarge igniter holes or burn pots. Failure to follow this warning could lead to a fire hazard and bodily harm and will void your warranty.
8. Product may have sharp edges or points. Contact may result in injury. Handle with care.

## **DISPOSAL OF ASHES**

Ashes should be placed in a metal container with a tight-fitting lid. The closed container of ashes should be placed on a non-combustible floor or on the ground, well away from all combustible materials, pending final disposal. When ashes are disposed by burial in soil, or otherwise locally dispersed, they should be retained in a closed container until all cinders have thoroughly cooled.

## **WOOD PELLET FUEL**

This pellet cooking appliance is designed and approved for pelletized, all natural, wood fuel only. Any other type of fuel burned in this appliance will void the warranty and safety listing. You must only use all natural wood pellets, designed for burning in pellet barbecue grills. Do not use fuel with additives. Wood pellets are highly susceptible to moisture and should always be stored in an airtight container. If you are storing your grill, without use, for an extended period, we recommend clearing all pellets from your grill's hopper and auger, to prevent jams.

**Do not use spirit, petrol, gasoline, lighter-fluid or kerosene for lighting or refreshing a fire in your grill. Keep all such liquids well away from the appliance when in use.**

At time of printing, there is no industry standard for barbecue wood pellets, although most pellet mills use the same standards to make wood pellets for domestic use. Further information can be found at [www.pelletheat.org](http://www.pelletheat.org) or the *Pellet Fuel Institute*.

Contact your local dealer on the quality of pellets in your area and for information on brand quality. As there is no control over the quality of pellets used, we assume no responsibility to damage caused by poor quality of fuel.

## **CREOSOTE**

Creosote, or soot, is a tar-like substance. When burning, it produces black smoke with a residue which is also black in color. Soot or creosote is formed when the appliance is operated incorrectly, such as: blockage of the combustion fan, failure to clean and maintain the burn area, moisture affected pellets, or poor air-to-fuel combustion.

It is dangerous to operate this appliance should the flame become dark, sooty, or if the burn pot is overfilled with pellets. When ignited, this creosote makes an extremely hot and uncontrolled fire, similar to a grease fire. Should this happen, turn the unit OFF, let it cool completely, then inspect for maintenance and cleaning. It commonly accumulates along exhaust areas.

If creosote has formed within the unit, allow the unit to warm up at a low temperature, turn off the appliance, then wipe away any formation with a hand towel. Similar to tar, it is much easier to clean when warm, as it becomes liquid.

## **CARBON MONOXIDE ("THE SILENT KILLER")**

Carbon monoxide is a colorless, odorless, tasteless gas produced by burning gas, wood, propane, charcoal or other fuel. Carbon monoxide reduces the blood's ability to carry oxygen. Low blood oxygen levels can result in headaches, dizziness, weakness, nausea, vomiting, sleepiness, confusion, loss of consciousness or death. Follow these guidelines to prevent this colorless, odorless gas from poisoning you, your family, or others:

- See a doctor if you or others develop cold or flu-like symptoms while cooking or in the vicinity of the appliance. Carbon monoxide poisoning, which can easily be mistaken for a cold or flu, is often detected too late.
- Alcohol consumption and drug use increase the effects of carbon monoxide poisoning.

Carbon monoxide is especially toxic to mother and child during pregnancy, infants, the elderly, smokers, and people with blood or circulatory system problems, such as anemia, or heart disease.

## SAFETY LISTING

In accordance with the procedures and specifications by Conformité Européenne (CE), Pit Boss Grills pellet cooking appliances demonstrates compliance through testing to the standards and directives that comply with all safety, health and environmental protection requirements by the EU (European Union) and the European Economic Area (EEA). This product meets Electromagnetic Compatibility (EMC, 2014/30/EU) standards, Low Voltage Directive (LVD, 2014/35/EU) standards, and is Restriction of Hazardous Substances (RoHS, 2011/65/EU, 2015/863) and Waste from Electrical and Electronic Equipment (WEEE, 2002/96/EC) compliant.

This product has been assessed and meets requirements imposed or covered by regulations in Australia and New Zealand and is represented by RCM mark.



### COPYRIGHT NOTICE

Copyright 2019. All right reserved. No part of this manual may be copied, transmitted, transcribed, stored in a retrieval system, in any form or by any means without expressed written permission of,

#### **Dansons**

3411 North 5th Avenue, Suite 500, Phoenix, AZ, USA 85013  
[www.pitboss-grills.com](http://www.pitboss-grills.com)

Customer Service in Australia and New Zealand:

#### **Genesis International Corporation Pty Ltd.**

1/71 Truganina Road Malaga WA 6090  
**+61 8 9248 9822**  
[service@genesiscorp.com.au](mailto:service@genesiscorp.com.au)

# TABLE OF CONTENTS

Safety Information .....	2	Care & Maintenance .....	16
Parts & Specs.....	6	Using Wood Pellet Fuel.....	18
Assembly Preparation.....	7	Cooking Guidelines.....	18
Assembly Instructions		Tips & Techniques .....	20
Mounting The Support Legs To Main Cabinet.....	7	Troubleshooting .....	21
Securing The Control Panel To Support Legs .....	7	Electrical Wire Diagram .....	23
Mounting The Support Panels .....	8	Replacement Parts	
Securing The Support Bar.....	8	Smoker Replacement Parts .....	24
Mounting The Grease Exhaust Tube.....	8	Hopper Replacement Parts.....	25
Attaching The Heat Shield .....	8	Warranty	
Mounting The Power Cord Bracket.....	9	Conditions.....	25
Securing The Grease Tray Brackets.....	9	Exceptions.....	26
Placing The Grease Tray .....	9	Ordering Replacement Parts .....	26
Attaching The Hopper Clean-Out Door Knob .....	9	Contact Customer Service .....	26
Mounting The Back Handle .....	10	Warranty Service .....	26
Securing The Chimney.....	10	Accessories Sold Separately.....	27
Installing The Lid Stopper .....	10	Recipes .....	28
Mounting The Cabinet Door Handle, Door Latch .....	10		
Installing The Cooking Components .....	11		
Connecting To A Power Source.....	11		
Operating Instructions			
Smoker Environment.....	12		
Smoker Temperature Ranges.....	13		
Understanding The Control Board .....	14		
Understanding The Probes .....	14		
Hopper Priming Procedure .....	15		
First Use – Smoker Burn-Off.....	15		
Automatic Start-Up Procedure.....	15		
Manual Start-Up Procedure .....	16		
Shutting Off Your Smoker .....	16		

# PARTS & SPECS

Part#	Description
1	Cooking Grids (x4)
2	Cooking Grid Support Brackets (x10)
3	Chimney Cap (x1)
4	Chimney Stack (x1)
5	Hopper Handle (x1)
6	Lid Stopper (x1)
7	Main Cabinet (x1)
8	Cabinet Door Handle (x1)
9	Cabinet Door Latch (x1)
10	Power Cord Bracket (x1)
11	Support Panel (x2)
12	Support Bar (x1)
13	Water Pan (x1)
14	Flame Tamer (x1)
15	Support Leg With Wheel (x4)
16	Grease Tray (x1)
17	Grease Tray Brackets (x2)
18	Wire Components Housing (x1)
19	Grease Exhaust Tube (x1)
20	Heat Shield (x1)
21	Meat Probe (x1)
A	Door Knob (x1)
B	¼-20x½" Screw (x12)
C	¼-20x⅝" Screw (x4)
D	#10-24x½" Screw (x34)
E	#10-24x⅓" Screw (x2)

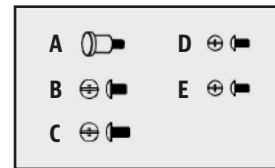
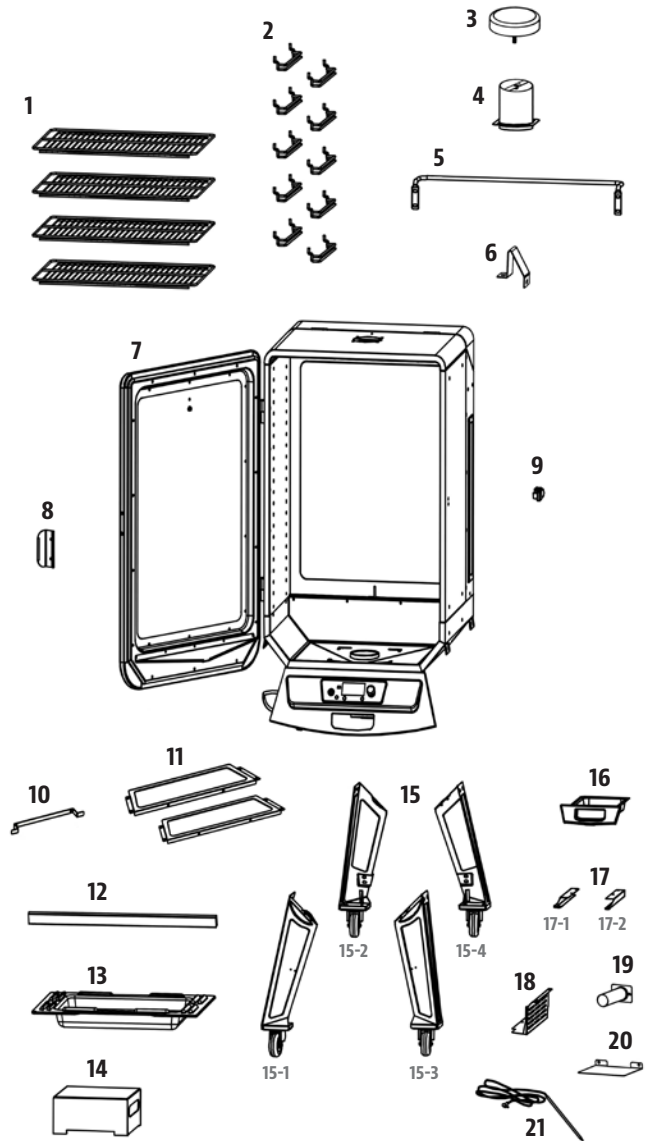

NOTE: Due to ongoing product development, parts are subject to change without notice. Contact Customer Service if parts are missing when assembling the unit.

**PB – ELECTRIC REQUIREMENTS**  
**230V, 2.1AMP, 50HZ, 250W, 3-PRONG GROUNDED PLUG**

MODEL	UNIT ASSEMBLED (WxHxD)	UNIT WEIGHT	COOKING AREA	TEMP. RANGE	DIGITAL FEATURES
PB PBV3P1	555 x 1339 x 640 mm / 21.7" x 52.7" x 25"	45.0 kg / 99.0 lb	<b>Cubic Cooking: 0.08 m<sup>3</sup> / 2.8 ft<sup>3</sup></b> <b>TOTAL - 4,650 cm<sup>2</sup> / 721 sq. in.</b>	65-230°C / 150-450°F	Ten temperature presets, start-up and cool-down cycles, electric igniter

# ASSEMBLY PREPARATION

Parts are located throughout the shipping carton, including underneath the grill. Inspect the grill, parts, and hardware blister pack after removing from the protective shipping carton. Discard all packaging materials from inside and outside of the grill before assembly, then review and inspect all parts by referencing the parts list. If any part is missing or damaged, do not attempt to assemble. Shipping damage is not covered under warranty. Contact Bunnings Australia or Genesis International Corporation Pty Ltd. for Customer Service.

service@genesiscorp.com.au | +61 8 9248 9822

**IMPORTANT: To ease installation, using two people is helpful (but not necessary) when assembling this unit.**

**Tools required for assembly:** screwdriver and level. *Tools not included.*

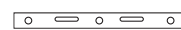
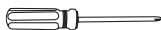

# ASSEMBLY INSTRUCTIONS

**IMPORTANT: It is advised to read each step entirely before starting assembly on instructions. Do not tighten screws completely until all screws for that step have been installed, or unless otherwise mentioned.**

## 1. MOUNTING THE SUPPORT LEGS TO MAIN CABINET

### Parts Required:

- 1 x Main Cabinet (#7)
- 4 x Support Leg With Wheel (#15)
- 12 x ¼-20x½" Screw (#B)

### Installation:

- Place a piece of cardboard on the floor to prevent scratching the unit and parts during assembly. First, lift the main cabinet door off the hinges, and place aside. Note illustration 1A.
- Next, flip the main cabinet, bottom side pointed upward, on the cardboard. Prepare the four support legs for installation, arranging the labelled legs as shown in illustration 1B.

**IMPORTANT: The four support legs must be arranged correctly to be able to properly install the support panels and support bar in a later assembly step.**

- Mount one support leg to the smoke cabinet using three screws. Repeat installation for the other three support legs. Note illustration 1C.

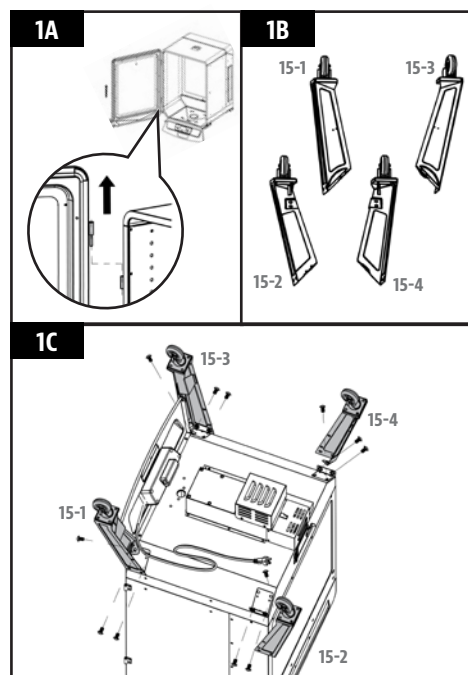

## 2. SECURING THE CONTROL BOARD TO SUPPORT LEGS

### Parts Required:

- 2 x #10-24x½" Screw (#D)

### Installation:

- Near the Control Board, loosen the two pre-assembled screws connecting the front panel to the main cabinet. Note 2A.
- Next, using another two screws (#D), secure the front panel sides to the front-facing support legs. Once these screws are tight, re-tighten the two screws that were previously loosened in 2A. Note 2B.

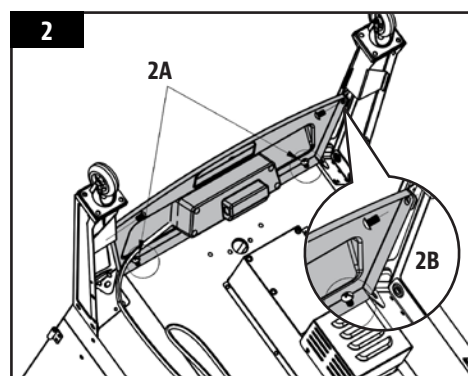

### 3. MOUNTING THE SUPPORT PANELS

#### Parts Required:

- 2 x Support Panel (#11)
- 8 x #10-24x $\frac{1}{2}$ " Screw (#D)

#### Installation:

- Install one support panel to the side of the unit between a front and back support leg. Secure using two screws on each side. Ensure the flat side of the support panel is facing outwards. Repeat the same installation to mount the other support panel. Note illustration for support panel arrangement.

**NOTE:** Ensure the support panel with two holes along the bottom is on the same side of the unit as the power cord exits the control board (left side). This is important for later steps.

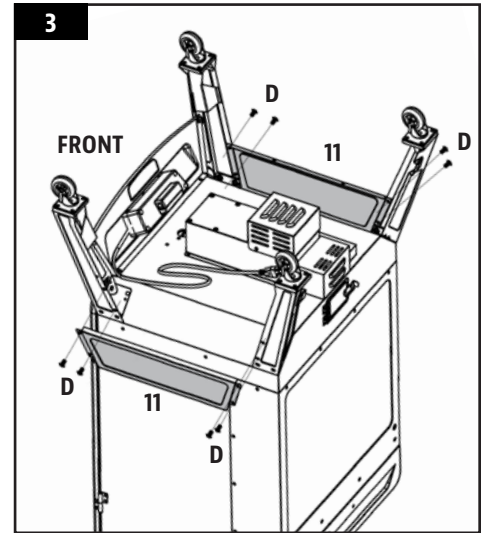

### 4. SECURING THE SUPPORT BAR

#### Parts Required:

- 1 x Support Bar (#12)
- 4 x #10-24x $\frac{1}{2}$ " Screw (#D)

#### Installation:

- Install the support bar to the back of the unit between the two back support legs. Secure using two screws on each side. Ensure the support bar is placed on the underside of the main cabinet, facing inwards. Note illustration for support bar arrangement.

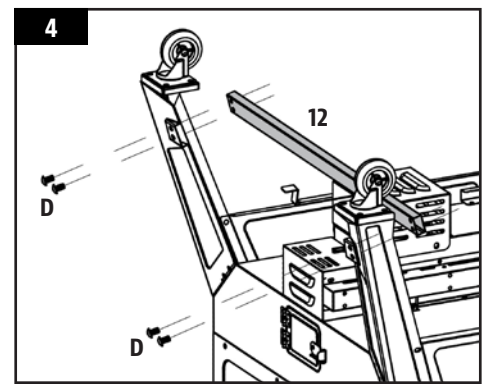

### 5. MOUNTING THE GREASE EXHAUST TUBE

#### Parts Required:

- 1 x Grease Exhaust Tube (#19)
- 2 x #10-24x $\frac{1}{3}$ " Screw (#E)

#### Installation:

- Mount the grease exhaust tube to the underside of the main cabinet using two screws.

**IMPORTANT:** Ensure there is a good seal to the main cabinet, as grease will come from the main cabinet, flow through the exhaust tube, and exit into the grease tray.

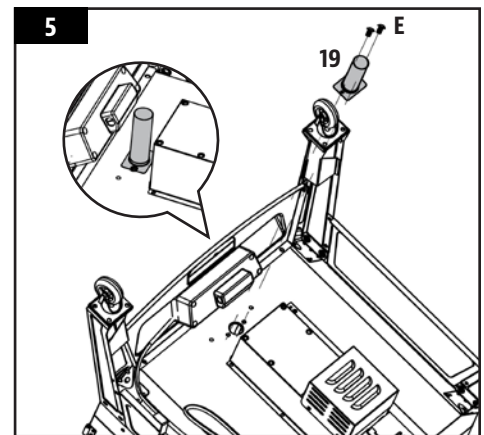

### 6. ATTACHING THE HEAT SHIELD

#### Parts Required:

- 1 x Heat Shield (#20)
- 2 x #10-24x $\frac{1}{2}$ " Screw (#D)

#### Installation:

- Position the heat shield between the control board and the grease exhaust tube. Secure using a screw on each side.

**IMPORTANT:** If this part is not installed correctly, the heat and/or splatter from the grease exhaust tube may cause damage to the control board. Grease damage to the rear of control board is not covered by warranty.

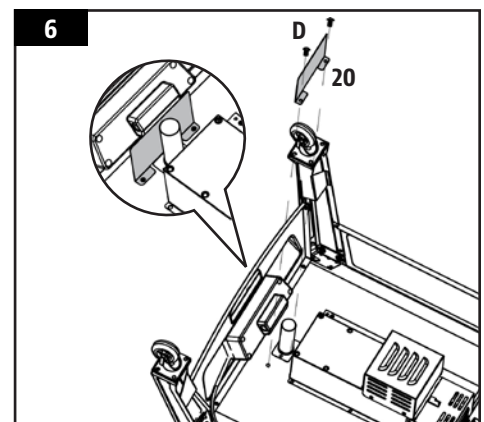



## 7. MOUNTING THE POWER CORD BRACKET

### Parts Required:

- 1 x Power Cord Bracket (#10)
- 2 x #10-24x $\frac{1}{2}$ " Screw (#D)

### Installation:

- Locate the two holes on the bottom of the (left side) support panel. Mount the power cord bracket to the support panel using two screws, as shown in 7A.
- Next, loosen the nut on the pre-mounted clip bracket and guide the power cord through the clip bracket. Once through, tighten the nut, and wrap the power cord on the bracket until unit is in use. Note 7B, 7C.

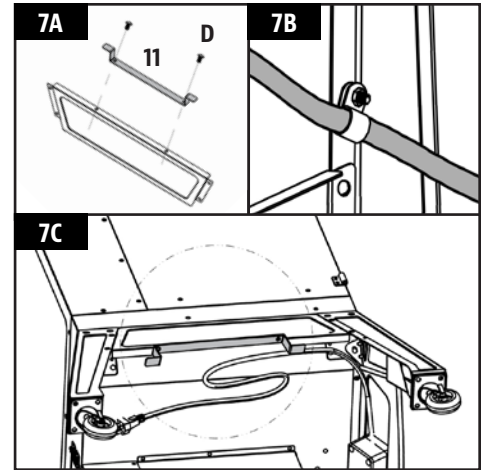

## 8. SECURING THE GREASE TRAY BRACKETS

### Parts Required:

- 1 x Wire Components Housing (#18)
- 2 x Grease Tray Brackets (#17)
- 6 x #10-24x $\frac{1}{2}$ " Screw (#D)

### Installation:

- First, mount the wire components housing onto the base of the auger housing using two screws in each bracket. Note 8A.
- Secure the grease tray brackets onto the base of the auger housing and the wire components housing using two screws in each bracket. Note illustration 8B for proper placement.

### NOTE: The diveted end of the brackets should face the control board.

- Fully-tighten all screws on the cart base. Next, carefully turn the unit into an upright position, with the wheels on the bottom. Ensure its level.

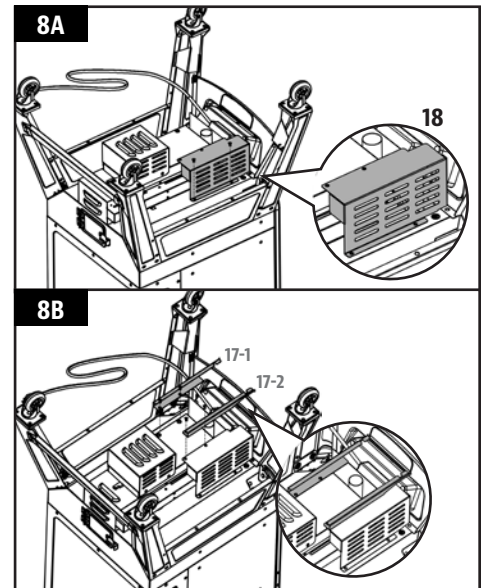

## 9. PLACING THE GREASE TRAY

### Parts Required:

- 1 x Grease Tray (#16)

### Installation:

- Slide the grease tray into the grease tray brackets on the front underside of the main cabinet, under the control board.

### NOTE: The grease tray is completely inserted once the front of the tray is pushed in as far as it can go, with no gap between the grease tray and the front panel.

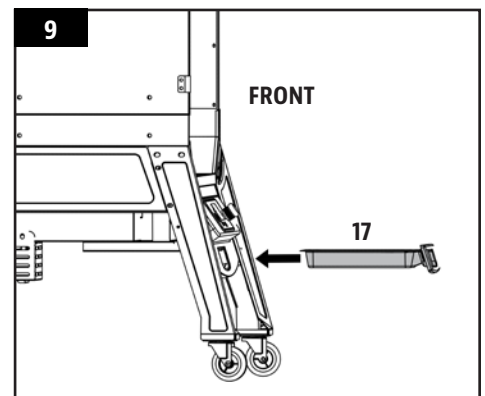

## 10. ATTACHING THE HOPPER CLEAN-OUT DOOR KNOB

### Parts Required:

- 1 x Door Knob (#A)

### Installation:

- Attach the door knob to the hopper clean-out door by rotating the part into the hole on the door. Rotate until completely fastened and clean-out door latch is secured.

### NOTE: To use the hopper clean-out feature, simply loosen the door knob, raise the clean-out door latch and open the door.

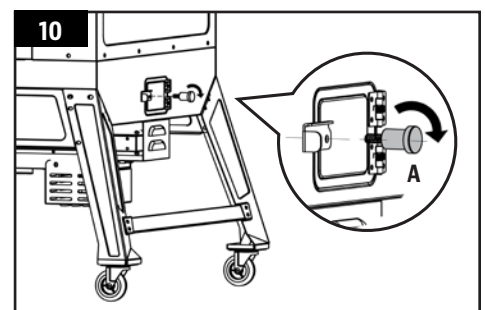

## 11. MOUNTING THE BACK HANDLE

### Parts Required:

- 1 x Hopper Handle (#5)
- 4 x  $\frac{1}{4}$ -20x $\frac{5}{8}$ " Screw (#C)

### Installation:

- Mount the hopper handle onto the back side of the hopper using four screws (#C). Note correct position in illustration with handle on top.

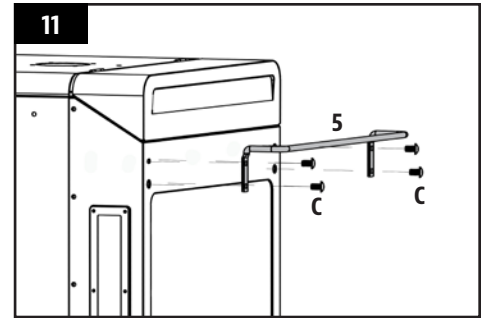

## 12. SECURING THE CHIMNEY

### Parts Required:

- 1 x Chimney Cap (#3)
- 1 x Chimney Stack (#4)
- 4 x #10-24x $\frac{1}{2}$ " Screw (#D)

### Installation:

- Locate the chimney opening on the top of the main cabinet. From the outside, secure the chimney stack to the top of the main cabinet using four screws. The screw will fasten to the self-clinching nuts on the inside of the cabinet. Next, twist the chimney cap onto the top of the chimney stack.

**NOTE: Adjust the chimney cap to affect the airflow inside the main cabinet. If cooking at low temperature, keep the cap more open.**

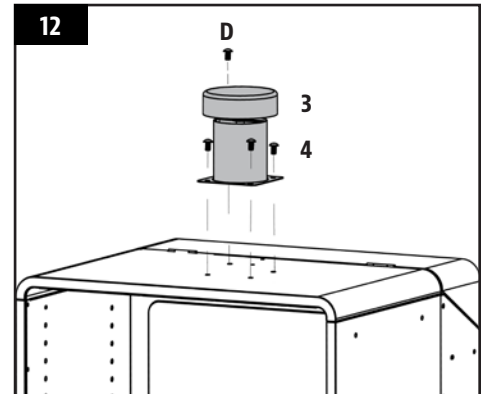

## 13. INSTALLING THE LID STOPPER

### Parts Required:

- 1 x Lid Stopper (#6)
- 2 x #10-24x $\frac{1}{2}$ " Screw (#D)

### Installation:

- Install the lid stopper onto the top of the main cabinet near the hopper lid. Use one screw to secure on the top side, then open the lid and secure one screw on the inside edge between the hopper lid hinges.

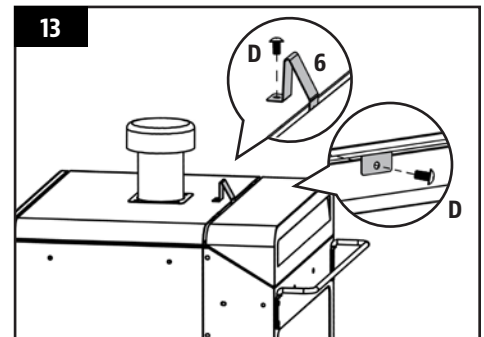

## 14. MOUNTING THE CABINET DOOR HANDLE, DOOR LATCH

### Parts Required:

- 1 x Cabinet Door Handle (#8)
- 1 x Cabinet Door Latch (#9)
- 4 x #10-24x $\frac{1}{2}$ " Screw (#D)

### Installation:

- First, remount cabinet door to the main cabinet by aligning and securing both hinges. Ensure the door is mounted correctly by testing it opens freely. Note 14A.
- Mount the cabinet door handle onto the front side of the cabinet door using two screws. Note correct direction in 14B.
- Mount the cabinet door latch onto the exterior side of the main cabinet using two screws. Note 14C.

**IMPORTANT: Fine tune and test the cabinet door latches and hooks to ensure they align properly and there is a proper seal while the door is closed. Poor alignment may result in heat loss and leaks during use.**

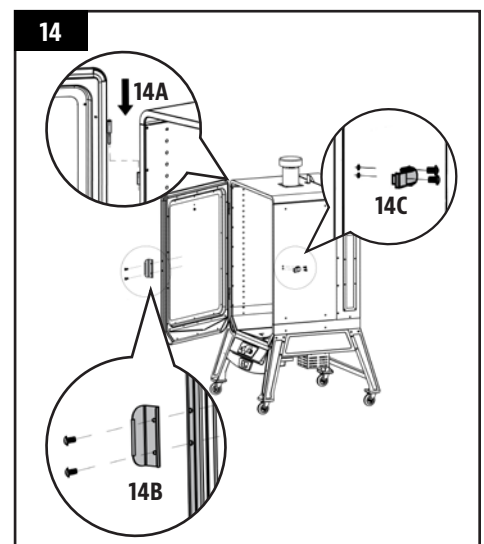

## 15. INSTALLING THE COOKING COMPONENTS

### Parts Required:

- 10 x Cooking Grid Support Brackets (#2)
- 4 x Cooking Grids (#1)
- 1 x Water Pan (#13)
- 1 x Flame Tamer (#14)

### Installation:

- Insert five cooking grid support brackets into the holes along the left side wall of the interior main cabinet. Once positioned in the holes, tilt downward to secure into position. Repeat the same process, matching the same heights, for the right side wall. Note illustration 15A.
- Place the flame tamer over the burn pot at the bottom of the interior main cabinet. To ensure proper positioning, align the flame tamer into the grooves along the bottom of the base panel. Note illustration 15B.

**IMPORTANT: The ventilation windows on the sides of the flame tamer box must not face forward, towards the cabinet door. This may cause damage to the control board if flames are too large.**

- Next, insert the water pan into the lowest grid support brackets of the interior cabinet. Fill your water pan about  $\frac{3}{4}$  full of water.

**IMPORTANT: Keep water in the water pan at all times while cooking. It will catch grease and drippings from your cooks and allow for easier clean up. If smoking for an extended period of time, move water pan up higher to allow water to last longer.**

- Last, place the cooking grids, one-by-one, on the grid support brackets inside the main cabinet. Note illustration 15C.
- The unit is now completely assembled.

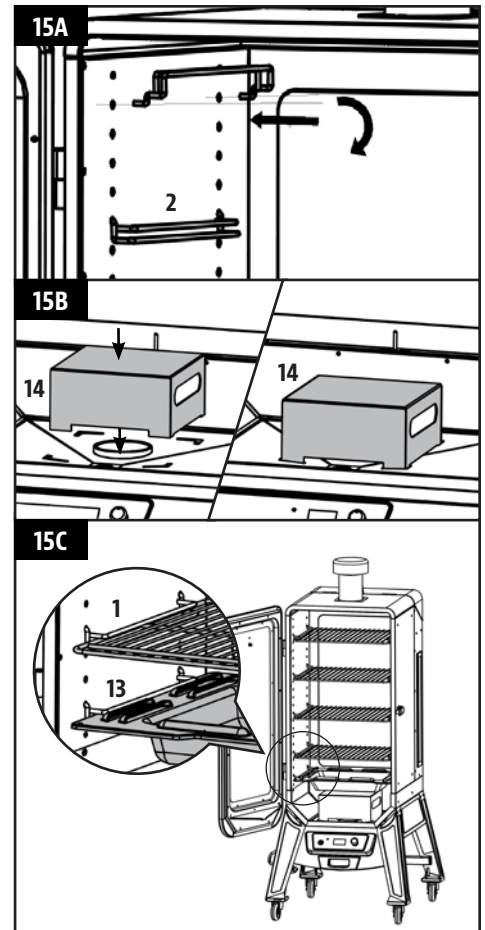

## 16. CONNECTING TO A POWER SOURCE

**NOTE: Before plugging your unit into any electrical outlet, ensure the temperature dial is in the OFF position. Disconnect when not in use.**

- **STANDARD OUTLET**  
This unit requires 230 volt, 50hz, 250w, 2.1 amp service. It must be a 3-prong grounded plug. Ensure grounded end is not broken off. The control uses a 5 amp, 120 volt, fast-blow fuse to protect the board from the igniter.
- **GFCI OUTLETS**  
This appliance will work on most GFCI outlets, with a recommended size of 15 amp service. If your GFCI outlet is highly sensitive to power surges, it will likely trip during the start-up phase of operation. During the start-up phase, the igniter draws 200-700 watts of electricity, which can be too much power for a GFCI outlet to handle. Each time it trips, it increases in sensitivity. If the GFCI keeps tripping, replace the outlet or change to a non-GFCI outlet.
- **ON THE ROAD**  
Disconnect the igniter from the main wiring harness. Use the manual start-up procedure. A Pit Boss unit can operate using a 12 volt, 100 watt inverter plugged into your automobile outlet. To use the automatic igniter, it is recommended to use a minimum of a 1000 watt inverter.

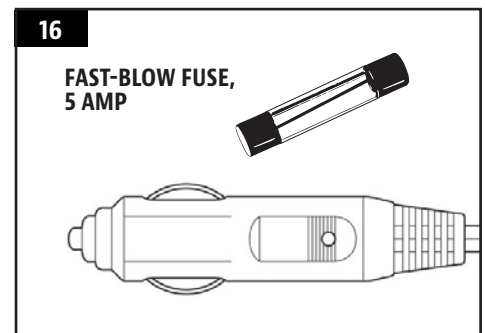

# OPERATING INSTRUCTIONS

*With today's lifestyle of striving to eat healthy and nutritious foods, a factor to consider is the importance of reducing fat intake. One of the best ways to cut down on fat in your diet is to use a low fat method of cooking, such as smoking. As a pellet smoker uses natural wood pellets, the savory wood flavor is cooked into the meats, reducing the need for high sugar-based sauces.*

## SMOKER ENVIRONMENT

### 1. *WHERE TO SET-UP THE SMOKER*

With all outdoor appliances, outside weather conditions play a big part in the performance of your smoker and the cooking time needed to perfect your meals. All Pit Boss units should keep a minimum clearance of 305mm (12 inches) from combustible constructions, and this clearance must be maintained while the smoker is operational. This appliance must not be placed under overhead combustible ceiling or overhang. Keep your smoker in an area clear from combustible materials, gasoline and other flammable vapors and liquids.

### 2. *COLD WEATHER COOKING*

As it becomes cooler outside, that does not mean that grilling season is over! The crisp cool air and heavenly aroma of smoked foods will help cure your winter blues. Follow these suggestions on how to enjoy your smoker throughout the cooler months:

- If smoking at low temperatures fails, increase the temperature slightly to achieve the same results.
- Organize – Get everything you require ready in the kitchen before you head outdoors. During the winter, move your smoker to an area that is out of the wind and direct cold. Check local bylaws regarding the proximity of your smoker in relation to your home and/or other structures. Put everything you need on a tray, bundle up tight, and get it done!
- To help keep track of the outside temperature, place an outdoor thermometer close to your cooking area. Keep a log or history of what you cooked, the outdoor temperature, and the cooking time. This will help later down the road to help you determine what to cook and how long it will take.
- In very cold weather, increase your preheating time by at least 20 minutes.
- Avoid opening the smoke cabinet door any more than necessary. Cold gusts of wind can completely cool your internal temperature. Be flexible with your serving time; add about 10 – 15 minutes extra cooking time each time you open the door.
- Have a heated platter or a dish cover ready to keep your food warm while making the trip back inside.
- Ideal foods for winter cooking are those that require little attention, such as roasts, whole chickens, ribs, and turkey. Make your meal preparation even easier by adding simple items such as vegetables and potatoes.

### 3. *HOT WEATHER COOKING*

As it becomes warmer outdoors, the cooking time will decrease. Proper dress is important when it gets really hot: shorts, shirt, shoes, hat, apron and a generous slab of suntan lotion is recommended. Follow these few suggestions on how to enjoy your smoker throughout the hot months:

- Adjust your cooking temperatures downward. This helps to avoid unwanted flare-ups.
- Use a meat thermometer to determine the internal temperature of your foods. This helps in preventing your meat from over cooking and drying out.
- Even in hot weather, keep the smoke cabinet door closed at all times.
- You can keep foods hot by wrapping them in foil, and placing them in an insulated cooler. Stuff crumpled up newspaper around the foil and this will keep food hot for 3 to 4 hours.

## SMOKER TEMPERATURE RANGES

Temperature readouts on the control board may not exactly match the thermometer. All temperatures listed below are approximate and are affected by the following factors: outside ambient temperature, the amount and direction of wind, the quality of pellet fuel being used, the cabinet door being opened, and the quantity of food being cooked.

- *HIGH TEMPERATURE (190-215°C / 375-420°F)*

This range is used to grill at high heat, without any contact with flame. High temperature is also used as the burn-off temperature to clean off the cooking grids after use. Additionally, high heat can be used in extreme cold weather conditions to compensate for the contrast of temperatures between outside and inside the unit.

- *MEDIUM TEMPERATURE (135-177°C / 275-350°F)*

This range is best for baking, roasting, and finishing off that slow smoked creation. Cooking at these temperatures will greatly reduce the chances of a grease flare-up. Great range for cooking anything wrapped in bacon, or where you want versatility with control.

- *LOW TEMPERATURE (65-122°C / 150-250°F)*

This range is used to slow roast, increase smoky flavor, and to keep foods warm. Infuse more smoke flavor and keep your meats juicy by cooking longer at a lower temperature (also known as **low and slow**). Highly recommended for the big turkey at Thanksgiving, juicy ham at Easter, or the huge holiday feast.

Smoking is a variation on true barbecuing and is truly the main advantage of a smoker. There are two types of smoking: hot smoking and cold smoking.







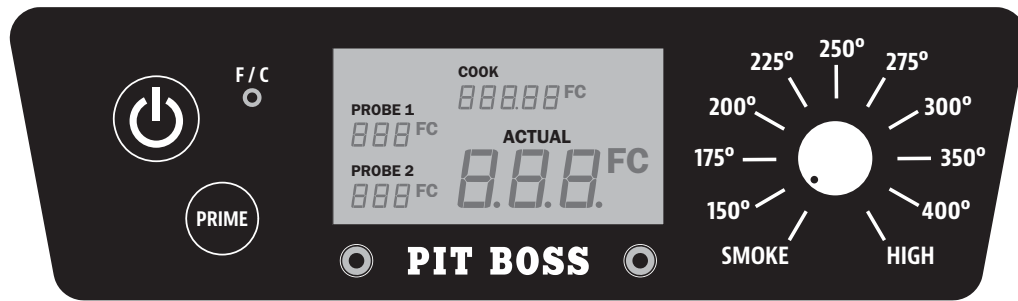

- **Hot smoking**, another name for **low and slow** cooking, is generally done at 82-122°C / 180-250°F. Hot smoking works best when longer cooking time is required, such as large cuts of meats, fish, or poultry.
- **Cold smoking** is when the food is located so far away from the fire that it smokes without cooking, and at temperatures of 15-32°C / 60-90°F.

**TIP: To intensify that savory flavor, switch to SMOKE (low) temperature range immediately after putting your food on the smoker. This allows the smoke to penetrate the meats, before the pores of the meat close at 49°C / 120°F.**

The key is to experiment with the length of time you allow for smoking, before the meal is finished cooking. Some outdoor chefs prefer to smoke at the end of a cook, allowing the food to keep warm until ready to serve. Practice makes perfect!

## UNDERSTANDING THE CONTROL BOARD



CONTROL	DESCRIPTION
	Press the <b>Power Button</b> to power on the unit. Once connected to a power source and the Power Button is pressed, the Digital LED Screen will light up, displaying that it is ready to operate. Press and hold the button to turn the unit off.
	The <b>Temperature Control Dial</b> allows you to set your desired smoking temperature. Select from any of the ten preset temperatures on the dial control, between 65-215°C / 150-420°F.
	The <b>Temperature Switch Button</b> is used to change the temperature readout on the LED Screen. Press the button to switch to Celsius (°C) or to Fahrenheit (°F), as preferred. Default is set to Fahrenheit.
	The <b>Digital LED Screen</b> is used as the information center for your unit. The LED screen will display your Desired Cook Temperature, Actual Cook Temperature, and Meat Probe Temperatures (if connected). If only one Meat Probe is connected, only one reading will be displayed. Temperature can be displayed in either Fahrenheit or Celsius.
	Press and hold the <b>Prime Button</b> to activate an extra feed of pellets to the burn pot. This can be used to add more fuel to the fire just before opening the smoke cabinet door, resulting in a quicker heat recovery time. It can also be used to add more fuel while smoking, to increase the intensity of clean smoke flavor. Requested from the competition cookers.
	The <b>Smoke Setting</b> on the Temperature Control Dial is the start-up mode for the unit. The smoker operates at the lowest temperature, without the fire going out.
	The plug-in connection port(s) on the front of the Control Board are for a <b>Meat Probe(s)</b> . When a meat probe is connected, the temperature is displayed on the LED Screen. When not in use, disconnect the meat probe from the connection port. <i>Includes one (1) meat probe. Compatible with Pit Boss branded meat probes only. Additional meat probe(s) sold separately.</i> 

## UNDERSTANDING THE PROBES

### • TEMPERATURE PROBE

Located inside the cabinet, on the rear wall along the bottom, is the temperature probe. It is a small, vertical piece of stainless steel. The temperature probe measures the internal temperature of the unit. When the temperature is adjusted on the Control Board, the temperature probe will read the actual temperature inside the unit and adjust to the desired temperature.

**IMPORTANT: The temperature of your unit is highly affected on ambient outdoor weather, quality of pellets used, flavor of pellets, and the quantity of food being cooked.**

### • MEAT PROBE

The meat probe measures the internal temperature of your meat in the smoke cabinet, similar to your indoor oven. Plug-in the meat probe adapter to the meat probe connection port and insert the stainless steel meat probe into the thickest portion of your meat and the temperature will be displayed on the control board. **To ensure the meat probe is connected properly to the connection port, feel and hear it snap into place.**

**IMPORTANT: When placing the meat probe into your meat, ensure the meat probe and meat probe wires avoid direct contact with flame or excess heat. This can result in damage to your meat probe. Run the excess wire out the front main cabinet door, along the edge. When not in use, disconnect from the meat probe connection port, and place aside to keep it protected and clean.**

## **HOPPER PRIMING PROCEDURE**

These instructions should be followed the first time the smoker is ignited, and each time the smoker runs out of pellets in the hopper. The auger must be primed to allow pellets to travel through the length of the auger, and fill the burn pot. **If not primed, the igniter will timeout before the pellets are ignited. Follow these steps to prime:**

1. Open the hopper lid. Make sure there are no foreign objects in the hopper or blocking the auger feed system at the bottom.
2. Remove all cooking components from the interior of the smoker. Locate the burn pot in the bottom of the smoke cabinet.
3. Plug the power cord into a power source. Press the **Power Button** to turn the unit ON, and turn the **Temperature Control Dial** to the SMOKE position. Check the following items:
  - That you can hear the auger turning. Place your hand above the burn pot and feel for air movement. Do not place your hand or fingers inside the burn pot. This can cause injury.
  - After approximately a minute, you should smell the igniter burning and begin to feel the air getting warmer in the burn pot. The igniter tip does not glow red hot. Do not touch the igniter. This item gets extremely hot and will burn.
4. Once verified that all electric components are working correctly, press and hold the **Power Button** to turn the unit OFF.
5. Fill the hopper with all natural barbecue wood pellets. Monitor the pellet level using the sight-glass along the side.
6. Press the **Power Button** to turn the unit ON. Turn the **Temperature Control Dial** to the SMOKE position. Press and hold the **Prime Button** until you see pellets entering the burn pot from the auger tube. Once pellets begin to drop into the burn pot, release the **Prime Button**. Allow the pellets to ignite and create flame. Once flames are coming out of the burn pot, press and hold the **Power Button** to turn the control board OFF, and let the smoker cool down.
7. Re-install the cooking components into the main cabinet. The smoker is now ready to use. (See *Assembly Instructions* to ensure proper installation of cooking components.)

## **FIRST USE – GRILL BURN-OFF**

Once your hopper has been primed and before cooking on your grill for the first time, it is important to complete a grill burn-off. Start the grill and operate at any temperature over 176°C / 350°F (with the lid down) for 30 to 40 minutes to burn-off the grill and rid it of any foreign matter.

## **AUTOMATIC START-UP PROCEDURE**

1. Ensure the **Temperature Control Dial** is in the SMOKE position. Plug the power cord into a grounded power source.
2. Check the burn pot to ensure there is no obstruction for proper ignition. Open the hopper lid. Ensure there are no foreign objects in the hopper or auger feed system entry at the bottom of the cabinet. Fill the hopper with dry, all natural barbecue hardwood pellets.
3. Press the **Power Button** to turn the unit on. This will activate the start-up cycle. The auger feed system will begin to turn, the igniter will begin to glow and the fan will supply air to the burn pot. The smoker will begin to produce smoke while the start-up cycle is taking place. The cabinet door must remain open during the start-up cycle. To confirm the start-up cycle has begun properly, listen for a torchy roar, and notice some heat being produced.
4. Once the heavy, white smoke has dissipated, the start-up cycle is complete and you are ready to enjoy your grill at your desired temperature!

**IMPORTANT: When selecting a low or the SMOKE setting after preheating, the auger will continue to turn and feed pellets. This will momentarily raise the temperature, but temperature will eventually decrease and stabilize. Remember, you are trying to regulate a fire, so time is necessary to achieve your desired temperature.**

## IGNITER FAILURE PROCEDURE

If for any reason your electric igniter fails or your grill's flame dies out during a cook, check the following steps, or start your grill using the manual method.

1. Ensure the **Temperature Control Dial** is off and in the **SMOKE** position. Open the barrel lid. Remove the cooking components from inside. Remove all unburnt pellets and ash from the fire pot. Avoid touching the igniter to avoid injury, as it may be extremely hot.
2. Once all cooking components are removed and cleaned, press the **Power Button** to turn the unit on. Check the following:
  - Visually confirm that the igniter is working by placing your hand above the fire pot and feeling for heat.
  - Visually confirm that the igniter is protruding approximately 13mm / 0.5 inches in the fire pot.
  - Visually confirm that the auger is dropping pellets into the fire pot.
  - Confirm that the combustion fan is working by listening for a torchy roar.
3. If any of the above points are not working, follow **Troubleshooting** instructions.

## MANUAL START-UP PROCEDURE

1. Ensure the **Temperature Control Dial** is in the **SMOKE** position. Plug the power cord into a grounded power source.
2. Check burn pot to ensure there is no obstruction for proper ignition. Open the hopper lid. Ensure there are no foreign objects in the hopper or auger feed system. Fill hopper with dry, all natural hardwood barbecue pellets.
3. Open the cabinet door. Remove the cooking components to expose the burn pot. Place a generous handful of pellets into the burn pot. Squirt a gelled fire starter, or other appropriate pellet starter, over the top of the pellets. A small amount of solid fuel fire starter, such as one composed of sawdust and wax, or wood shavings, is also appropriate. Add another small amount of pellets over the burn pot.

**NOTE: Do not use spirit, petrol, gasoline, lighter-fluid or kerosene for lighting or refreshing a fire in your grill.**

4. Light the contents of the burn pot using a long match or long-nosed lighter. Allow the starter to burn for 3 to 5 minutes. Do not attempt to add more starter into the burn pot. This can cause injury.
5. Quickly and carefully replace the cooking components to the inside of the smoke cabinet. The cabinet door must remain open during the start-up cycle.
6. Continue start-up at step three of **Automatic Start-Up Procedure**.

## SHUTTING OFF YOUR SMOKER

1. When finished cooking, press and hold the **Power Button** to turn the unit OFF. The smoker will begin its automatic cool-down cycle. The auger system will stop feeding fuel, the flame will burn out, and the fan will continue to run until the cool-down cycle is complete.

# CARE AND MAINTENANCE

Any Pit Boss unit will give you many years of flavorful service with minimum cleaning. Follow these cleaning and maintenance tips to service your smoker:

### 1. HOPPER ASSEMBLY

- The hopper includes a clean-out feature to allow for ease of cleaning and change out of pellet fuel flavors. To empty, locate the clean-out door of the drop chute on the back side of the hopper. Place a clean, empty pail under the clean-out door, then slowly turn the knob and allow the pellets to empty.

**NOTE: Use a long handled brush or shop-vac to remove excess pellets, sawdust, and debris for a complete clean-out.**

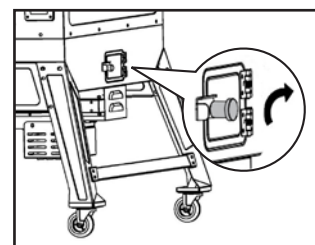



- Running all pellets out of your auger system is recommended if your grill will be unused for an extended period of time. This can be done by simply running your grill, on an empty hopper, until all pellets have emptied from the auger tube.
- Check and clean off any debris from the fan air intake vent, found on the rear underside of the smoke cabinet. For an extensive cleaning, carefully wipe off any grease build-up directly on the fan blades (see **Electric Wire Diagram** for access to electric components). This ensures airflow is sufficient to the feed system.

## 2. PROBES

- Kinks or folds in the probe wires may cause damage. A meat probe not in use should be rolled up in a large, loose coil.
- Although both the temperature probe and the meat probes are stainless steel, do not place in the dishwasher or submerge in water. Water damage to the internal wires will cause a probe to short-out, causing false readings. If a probe is damaged, it should be replaced.

## 3. INSIDE SURFACES

- It is recommended to clean your burn pot after every few uses. This will ensure proper ignition and avoid any hard build-up of debris or ash in the burn pot.
- Use a long-handled grill cleaning brush (brass or soft metal), remove any food or build-up from the cooking grids. Best practice is to do this while they are still warm from the previous cook. **Grease fires are caused by too much fallen debris on the cooking components of the smoker.** Clean the inside of your smoker on a consistent basis. In the event you experience a grease fire, keep the smoke cabinet door closed to choke out the fire. If the fire does not go out quickly, carefully remove the food, turn the smoker off, and shut the cabinet door until the fire is completely out. Another way to extinguish a fire is to wrap aluminum foil around the smoke stack, closing off air to the interior. Lightly sprinkle baking soda, if available. Check your grease tray often, and clean out as necessary. Keep in mind the type of cooking you do. Ensure the grease exhaust tube is clear of any blockages.

**IMPORTANT: The water pan may accumulate grease. Line the water pan with aluminum foil for easier clean up after cooks. Refill and replace the water in the water pan often.**

- The glass of the cabinet door is tempered and will not break with high heat; however, excessive build-up may cause the door to not close if not cleaned regularly. Smoke and debris can be removed with frequent cleaning of the glass.

## 4. OUTSIDE SURFACES

- Wipe your smoker down after each use. Use warm soapy water to cut the grease. Do not use oven cleaner, abrasive cleansers or abrasive cleaning pads on the outside grill surfaces. **All painted surfaces are not covered under warranty**, but rather are part of general maintenance and upkeep. For paint scratches, wearing, or flaking of the finish, all painted surfaces can be touched up using high heat BBQ paint.
- Use a cover to protect your smoker for complete protection! A cover is your best protection against weather and outside pollutants. When not in use or for longterm storage, keep the unit under a cover in a garage or shed.

**CLEANING FREQUENCY TIME TABLE (NORMAL USE)**

ITEM	CLEANING FREQUENCY	CLEANING METHOD
Main Cabinet Glass Door	Every 2-3 Smoke Sessions	Mix Baking Soda & Vinegar, Scrub with Steel Wool (Fine)
Bottom of Main Cabinet	Every 5-6 Smoke Sessions	Scoop Out, Shop-Vac Excess Debris
Burn Pot	After Each Smoke Session	Scoop Out, Shop-Vac Excess Debris
Cooking Grids	After Each Smoke Session	Burn Off Excess, Brass Wire Brush
Water Pan	After Each Smoke Session	Scrub Pad & Soapy Water
Grease Tray	After Each Smoke Session	Scrub Pad & Soapy Water
Grease Exhaust Tube	Every 5-6 Smoke Sessions	Scrub Pad & Soapy Water
Auger Feed System	When Pellet Bag is Empty	Allow Auger to Push Out Sawdust, Leaving Hopper Empty
Electric Components	Once A Year	Dust Out Interior, Wipe Fan Blades with Soapy Water
Air Intake Vent	Every 5-6 Smoke Sessions	Dust, Scrub Pad & Soapy Water
Temperature Probe	Every 2-3 Smoke Sessions	Scrub Pad & Soapy Water

# USING WOOD PELLET FUEL

Clean-burning barbecue wood pellets generate about 8200 BTU's per pound with very little ash, a low moisture content (5-7%), and are carbon neutral.

Barbecue wood pellets are produced by pure raw material (sawdust) being pulverized with a hammer-mill, and the material is pushed through a die with pressure. As the pellet is forced through the die, it is cut, cooled, screened, vacuumed, and then bagged for consumer use. Check with your local dealer for flavors available in your area.

## HICKORY BLEND

Rich, smoky bacon-like flavor. Considered the "Kings of the Woods".

## MESQUITE BLEND

Strong, tangy, spicy flavor. Think Tex-Mex cuisine.

## APPLE BLEND

Smoky, mild sweetness flavor. Highly recommended for baking.

## CHERRY BLEND

Slightly sweet, but also tart. Gives a rosy tint to light meals.

## WHISKEY BARREL BLEND

Strong, sweet smoke with aromatic tang. Perfect for red meats.

## COMPETITION BLEND

Perfect blend of sweet, savory, and tart. Used by many professional grillers.

**NOTE: Always store wood pellets in a dry area. Any contact or exposure to moisture will result in lower heat output or cause the pellets to swell and break apart. Use a moisture proof, resealable tub or bucket for proper storage.**

# COOKING GUIDELINES

Smoking and grilling styles of cooking can give you different results based on time and temperature. For best results, keep a record of what you cooked, at what temperature, how long you cooked for, and the results. Adjust to your taste for the next time. Practice makes perfect. The culinary art of hot smoking refers to longer cooking times, but results in more natural wood flavor (and a sought-after Pink Ring) on your meats. Higher temperatures result in a shorter cooking time, locking in less smoke flavor.

**TIP: For best results, allow time for meats to rest after cooking. This allows the natural juices to migrate back into the meat fiber, giving a much juicier, flavorful cut. Resting times can be as little as 3 minutes and up to 60 minutes, depending on the size of the protein.**

COOKING STYLE	HOT SMOKING	ROAST	BAKING (Medium)	GRILL (Medium/High)
Temperature Range	93-135°C / 200-275°F	135-162°C / 275-325°F	162-190°C / 325-375°F	204-215°C / 400-420°F

		APPROXIMATE COOKING TIME		
BEEF	Size	Rare - 54°C / 130°F	Medium - 60°C / 140°F	Well Done - 65°C / 150°F
Rib-eye Roast, boneless	2.26 - 2.72 kg / 5 - 6 lbs.		1½ - 2 hours	
Rib Roast	5.44 - 6.35 kg / 12 - 14 lbs.		2½ - 2¾ hours	
Sausage (fresh)	All sizes			4 - 5 hours
Roast (bone-in)	All sizes	4- 5 Hours		
Ribs	All sizes	Cook until meat pulls from the bone (approx 4 - 6 hours)		
Brisket	7.25 - 3.62 kg / 16 -18 lbs.	Cook until internal temperature reaches 91°C / 195°F		

<b>PORK</b>	<b>Size</b>	<b>Reheat - 60°C / 140°F</b>	<b>Medium - 66°C / 150°F</b>	<b>Well Done - 71°C / 160°F</b>
Ham (cooked)	All sizes	2 - 2¾ hours		
Ham (fresh)	4.53-5.44 kg / 10-12 lbs.			7 - 8 hours
Sausage (fresh)	All sizes			4 - 5 hours
Loin Roast	1.36-1.81 kg / 3 - 4 lbs.		1 - 2 hours	2 - 3 hours
Rib Crown Roast	1.81-2.26 kg / 4 - 5 lbs.		1½ - 2 hours	2 - 3 hours
Boston Butt (Pork Shoulder)	3.62-4.53 kg / 8-10 lbs.			93 - 98°C / 200 - 210°F Internal Temperature
Ribs	All sizes	Cook until meat pulls from the bone (approx 4 - 6 hours)		
Chop (loin, rib)	All sizes	Cook until meat pulls from the bone (approx 4 - 6 hours)		

<b>LAMB</b>	<b>Size</b>	<b>Rare - 54°C / 130°F</b>	<b>Medium - 60°C / 140°F</b>	<b>Well Done - 71°C / 160°F</b>
Roast (fresh)	2.26 - 2.72 kg / 5 - 6 lbs.		5 -6 Hours	

<b>POULTRY</b>	<b>Size</b>	<b>Rare - 54°C / 130°F</b>	<b>Medium - 60°C / 140°F</b>	<b>Well Done - 82°C / 180°F</b>
Turkey (whole)	4.53-5.44 kg / 10-12 lbs.			7 - 8 Hours
Chicken (whole)	All sizes			5 -6 Hours
Drumsticks, Breasts	All sizes			4 -5 Hours
Small Game Birds	All sizes			4 -5 Hours
Duck	1.36-2.26 kg / 3-5 lbs.			5 -6 Hours

<b>CHICKEN</b>	<b>Size</b>	<b>Rare - 54°C / 130°F</b>	<b>Medium - 60°C / 140°F</b>	<b>Well Done - 82°C / 180°F</b>
Whole	All sizes			5 -6 Hours
Drumsticks, Breasts	All sizes			4 -5 Hours

<b>FISH</b>	<b>Size</b>	<b>Rare - 54°C / 130°F</b>	<b>Medium - 60°C / 140°F</b>	<b>Well Done - 82°C / 180°F</b>
Whole	All sizes			2 -3 Hours, until flaky
Filets	All sizes			1 -2 Hours, until flaky

<b>WILD GAME</b>	<b>Size</b>	<b>Rare - 60°C / 140°F</b>	<b>Medium - 71°C / 160°F</b>	<b>Well Done - 77°C / 170°F</b>
Roast (fresh)	2.26 - 2.72 kg / 5 - 6 lbs.		5 -6 Hours	
Large Cuts (fresh)	3.62-4.53 kg / 8-10 lbs.			7 - 8 Hours

# TIPS & TECHNIQUES

Follow these helpful tips and techniques, passed on from Pit Boss owners, our staff, and customers just like you, to become more familiar with your smoker:

## 1. *FOOD SAFETY*

- Keep everything in the kitchen and cooking area clean. Use different platters and utensils for the cooked meat than the ones you used to prepare or transport the raw meat out to the smoker. This will prevent cross contamination of bacteria. Each marinade or basting sauce should have its own utensil.
- Keep hot foods hot (above 60°C / 140°F), and keep cold foods cold (below 3°C / 37°F).
- A marinade should never be saved to use at a later time. If you are going to use it to serve with your meat, be sure to bring it to a boil before serving.
- Cooked foods should not be left out in the heat for more than an hour. Do not leave hot foods out of refrigeration for more than two hours.
- Defrost and marinade meats by refrigeration. Do not thaw meat at room temperature or on a counter top. Bacteria can grow and multiply rapidly in warm, moist foods. Wash hands thoroughly with hot, soapy water before starting any meal preparation and after handling fresh meat, fish and poultry.

## 2. *COOKING PREPARATION*

- Be prepared, or ***Mise en Place***. This refers to preparing the cooking recipe, fuel, accessories, utensils, and all ingredients you require at your side before you start cooking. Also, read the entire recipe, start to finish, before lighting the smoker.
- A BBQ floor mat is very useful. Due to food handling accidents and cooking splatter, a BBQ floor mat would protect a deck, patio, or stone platform from the possibility of grease stains or accidental spills.

## 3. *SMOKING TIPS AND TECHNIQUES*

- To infuse more smoke flavor into your meats, cook longer and at lower temperatures (also known as ***low and slow***). Meat will close its fibers after it reaches an internal temperature of 49°C / 120°F. Misting, or mopping, are great ways to keep meat from drying out.
- Always use a meat thermometer to determine the internal temperature of the foods you are cooking. Smoking foods with hardwood pellets will turn meats and poultry pink. The band of pink (after cooking) is referred to as a ***smoke ring*** and is highly prized by outdoor chefs.
- Sugar-based sauces are best applied near the end of cooking to prevent burning and flare-ups.
- Leave open space between the foods and the extremities of the smoke cabinet for proper heat flow. Food on a crowded smoker will require more cooking time.
- Use a set of long-handled tongs for turning meats, and a spatula for softer items like fish and cheese. Using a piercing utensil, such as a fork, will prick the meat and allow the juices to escape.
- Foods in deep casserole dishes will require more time to cook than a shallow baking pan.
- It's a good idea to put cooked food onto a heated platter, keeping the food warm. Red meats, such as tenderloins and roasts, benefit from resting for several minutes before serving. It allows the juices that were driven to the surface by heat to ease back to the center of the meat, adding more flavor.

# TROUBLESHOOTING

Proper cleaning, maintenance and the use of clean, dry, quality fuel will prevent common operational problems. When your Pit Boss smoker is operating poorly, or on a less frequent basis, the following troubleshooting tips may be helpful.

For FAQ, please visit [www.pitboss-grills.com](http://www.pitboss-grills.com). You may also contact your local Pit Boss authorized dealer or contact Customer Service for assistance.

**WARNING: Always disconnect the electrical cord prior to opening the smoker for any inspection, cleaning, maintenance or service work. Ensure the smoker is completely cooled to avoid injury.**

Problem	Cause	SOLUTION
No Power Lights On The Control Board	Power Button	Press the Power Button. Try another attempt and hold for two seconds to verify connection.
	Not Connected To Power Source, GFCI Outlet Has Tripped	Ensure smoker is plugged into a working power source. Reset breaker. Ensure GFCI is a minimum 10 Amp service (see <b>Electric Wire Diagram</b> for access to electric components). Ensure all wire connections are firmly connected and dry.
	Fuse Blown On The Control Board	Remove cooking components from the main smoke cabinet. Turn the unit onto its side, and remove the screws on the rear side of the Control Board. Check the fuse for a broken wire or if the wire has turned black. If yes, manually replace with a new fuse.
	Faulty Control Board	Control Board needs to be replaced. Contact Customer Service for a replacement part.
Fire In Burn Pot Will Not Light	Auger Not Primed	Before the unit is used for the first time or anytime the hopper is completely emptied out, the auger must be primed to allow pellets to fill the burn pot. If not primed, the igniter will timeout before the pellets ignite. Follow <b>Hopper Priming Procedure</b> .
	Auger Motor Is Jammed	Remove cooking components from the main smoke cabinet. Press the Power Button to turn the unit on, turn Temperature Control Dial to SMOKE, and inspect the auger feed system. Visually confirm that the auger is dropping pellets into the burn pot. If not operating properly, call Customer Service for assistance or a replacement part.
	Igniter Failure	Remove cooking components from the main smoke cabinet. Press the Power Button to turn the unit on, turn Temperature Control Dial to SMOKE, and inspect the igniter. Visually confirm that the igniter is working by placing your hand above the burn pot and feeling for heat. Visually confirm that the igniter is protruding approximately 13mm / 0.5 inches in the burn pot. If not operating properly, follow <b>Manual Start-up Procedure</b> to continue use of smoker; however, call Customer Service for assistance or a replacement part.
	Insufficient Air Flow Through Fire Pot	Check fire pot for ash build-up or obstructions. Follow Care and Maintenance instructions for ash build-up. Check fan. Ensure it is working properly and air intake is not blocked. Follow <b>Care and Maintenance</b> instructions if dirty.
Flashing Dots On LED Screen	The Igniter Is On	This is not an error that effects the unit. Used to show that the unit has power and is in Start-Up mode (igniter is on). The igniter will turn off after five minutes. Once the flashing dots disappear, the grill will begin to adjust to the desired temperature selected.
Flashing Temperature On LED Screen	Grill Temperature Is Below 65°C /150°F	This is not an error that effects the unit; however, it is used to show that there is some risk that the fire could go out. Check hopper for sufficient fuel or if there is an obstruction in the feed system. Remove pellets and follow <b>Care and Maintenance</b> instructions. Check grill temperature probe and follow <b>Care and Maintenance</b> instructions if dirty. Check burn pot for ash build-up or obstructions, and follow <b>Care and Maintenance</b> instructions for ash build-up. Check fan. Ensure it is working properly and air intake is not blocked. Follow <b>Care and Maintenance</b> instructions if dirty. Check auger motor to confirm operation (rotation), and ensure there is no blockage in the auger tube.
"ErH" Error Code	The Smoker Has Overheated, Possibly Due To Grease Fire Or Excess Fuel.	Press and hold the Power Button to turn the unit off, and allow smoker to cool. Follow <b>Care and Maintenance</b> instructions. After maintenance, remove pellets, and confirm positioning of all component parts. Once cooled, press the Power Button to turn the unit on, then select desired temperature. If error code still displayed, contact Customer Service.

"Er1" Error Code	Temperature Probe Wire Not Making Connection	Access the electrical components on the base of the unit (see <b>Electric Wire Diagram</b> ) and check for any damage to the Temperature Probe wires. Ensure Temperature Probe spade connectors are firmly connected, and connected correctly, to the Control Board.
"noP" Error Code	Bad Connection At Connection Port	Disconnect meat probe from connection port on the Control Board, and reconnect. Ensure the meat probe adapter is firmly connected. Check for signs of damage to the adapter end. If still failed, call Customer Service for replacement part.
	Meat Probe Damaged	Check for signs of damage to the wires of the meat probe. If damaged, call Customer Service for replacement part.
	Faulty Control Board	Control Board needs to be replaced. Contact Customer Service for a replacement part.
Thermometer Shows Temperature When Unit Off	Smoker Has High Ambient Temperature Or Is In Direct Sun	This will not harm the smoker. The internal temperature of the main cabinet has ambiently reached or exceeded 54°C / 130°F. Move the smoker into a shaded area. Prop the cabinet door open to reduce the internal temperature.
Smoker Will Not Achieve Or Maintain Stable Temperature	Insufficient Air Flow Through Burn Pot	Check burn pot for ash build-up or obstructions. Follow <b>Care and Maintenance</b> instructions for ash build-up. Check fan. Ensure it is working properly and air intake is not blocked. Follow <b>Care and Maintenance</b> instructions if dirty. Check auger motor to confirm operation, and ensure there is no blockage in the auger tube. Once all the above steps have been done, start the smoker, set temperature to SMOKE and wait for 10 minutes. Check that the flame produced is bright and vibrant.
	Lack Of Fuel, Poor Fuel Quality, Obstruction In Feed System	Check hopper to check that fuel level is sufficient, and replenish if low. Should the quality of wood pellets be poor, or the length of the pellets too long, this may cause an obstruction in the feed system. Remove pellets and follow <b>Care and Maintenance</b> instructions.
	Temperature Probe	Check status of temperature probe. Follow <b>Care and Maintenance</b> instructions if dirty. Contact Customer Service for a replacement part if damaged.
Smoker Produces Excess Or Discolored Smoke	Grease Build-Up	Follow <b>Care and Maintenance</b> instructions.
	Wood Pellet Quality	Remove moist wood pellets from hopper. Follow <b>Care and Maintenance</b> instructions to clean out. Replace with dry wood pellets.
	Burn Pot Is Blocked	Clear burn pot of moist wood pellets. Follow <b>Hopper Priming Procedure</b> .
	Insufficient Air Intake For Fan	Check fan. Ensure it is working properly and air intake is not blocked. Follow <b>Care and Maintenance</b> instructions if dirty.
Frequent Flare-Ups	Cooking Temperature	Attempt cooking at a lower temperature. Grease does have a flash point. Keep the temperature under 176°C / 350°F when cooking highly greasy food.
	Grease Build-Up On Cooking Components	Follow <b>Care and Maintenance</b> instructions.

# ELECTRICAL WIRE DIAGRAM

The Control Board system is an intricate and valuable piece of technology. For protection from power surges and electrical shorts, consult the wire diagram below to ensure your power source is sufficient for the operation of the unit.

## PB – ELECTRIC REQUIREMENTS

230V, 2.1AMP, 50HZ, 250W, 3-PRONG GROUNDED PLUG

NOTE: Electrical components, passed by product safety testing and certification services, comply with a testing tolerance of ± 5-10 percent.

- 1** DISCONNECT POWER SUPPLY BEFORE SERVICE OR MAINTENANCE.



- 2** REMOVE TWO GREASE TRAY BRACKETS FROM UNDERSIDE OF UNIT.

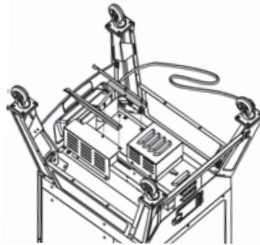

- 3** REMOVE WIRE COMPONENTS HOUSING FROM UNDERSIDE OF UNIT.

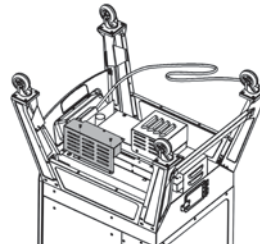

- 4** ACCESS WIRING COMPONENTS LOCATED IN TEMPERATURE PROBE HOUSING.

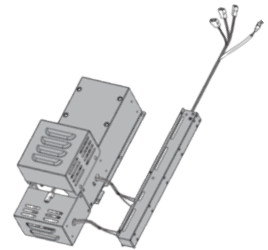

**FUEL INPUT RATING:**  
1.1 KG/H  
(2.4 LB/H)

### INDEX

W : WHITE  
Y : YELLOW  
P : PURPLE  
R : RED  
K : BLACK  
S : SILVER

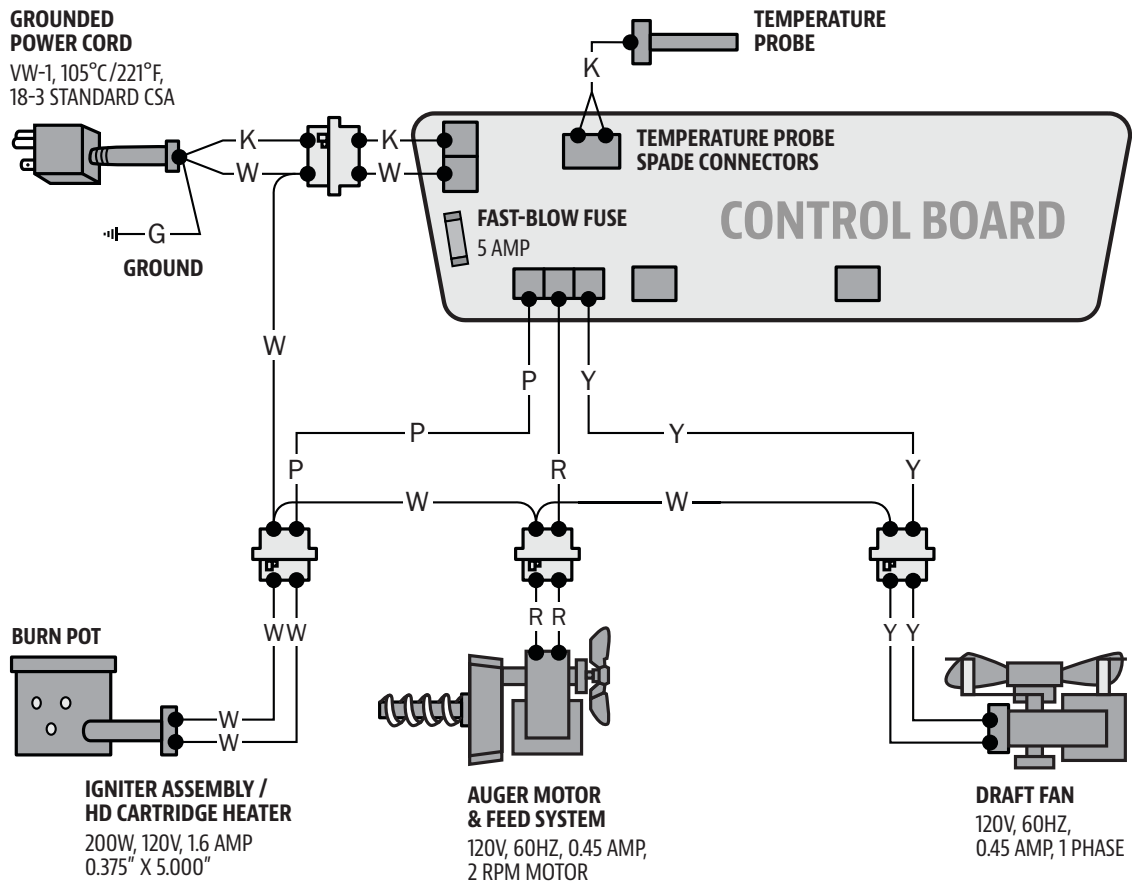

# REPLACEMENT PARTS

Part#	Description
1-A	Cooking Grids (x4)
2-A	Cooking Grid Support Brackets (x10)
3-A	Chimney Cap (x1)
4-A	Chimney Stack (x1)
5-A	Hopper Handle (x1)
6-A	Lid Stopper (x1)
7-A	Main Cabinet (x1)
8-A	Cabinet Door Handle (x1)
9-A	Cabinet Door Latch (x1)
10-A	Power Cord Bracket (x1)
11-A	Support Panel (x2)
12-A	Support Bar (x1)
13-A	Water Pan (x1)
14-A	Flame Tamer (x1)
15-A	Support Leg With Wheel (x4)
16-A	Grease Tray (x1)
17-A	Grease Tray Brackets (x2)
18-A	Wire Components Housing (x1)
19-A	Grease Exhaust Tube (x1)
20-A	Heat Shield (x1)
21-A	Meat Probe (x1)
22-A	Door Knob (x1)
23-A	1/4-20x1/2" Screw (x12)
24-A	1/4-20x5/8" Screw (x4)
25-A	#10-24x1/2" Screw (x34)
26-A	#10-24x1/3" Screw (x2)

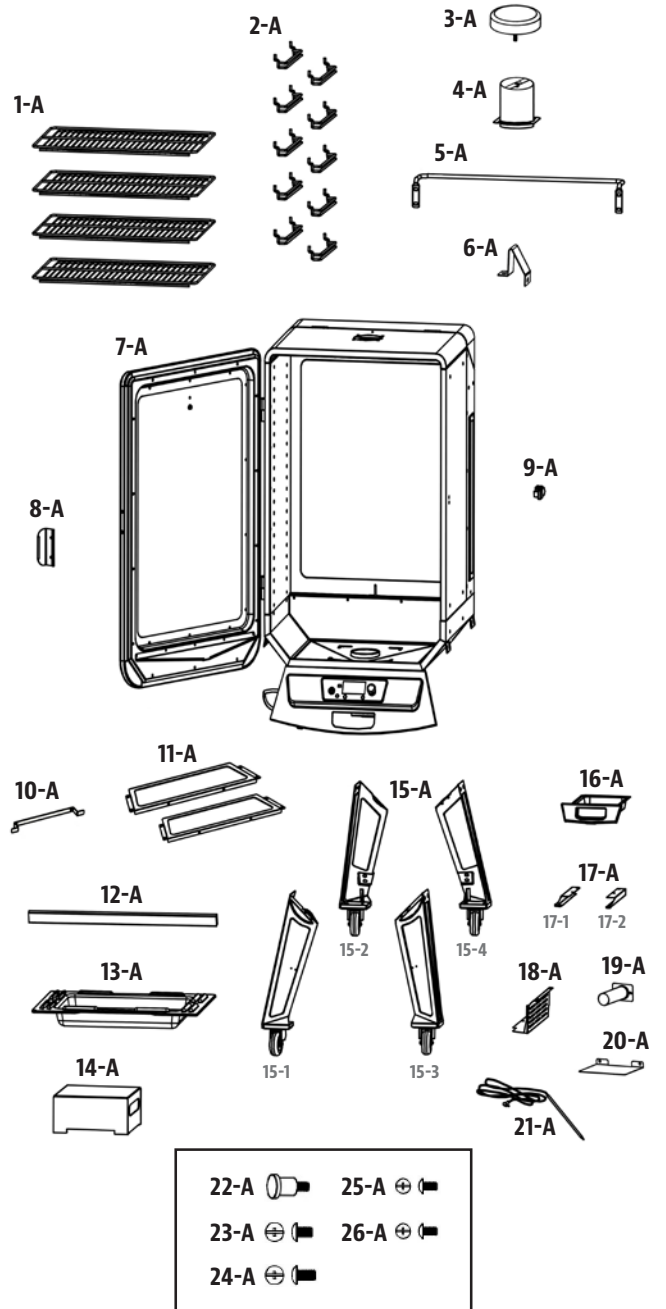

NOTE: Due to ongoing product development, parts are subject to change without notice.



# REPLACEMENT PARTS

Part#	Description
1-PVH	Burn Pot
2-PVH	Igniter
3-PVH	Auger Box Housing
4-PVH	Auger Flighting Assembly
5-PVH	Auger Motor Left Bracket
6-PVH	Auger Motor
7-PVH	Auger Motor Right Bracket
8-PVH	Auger Motor Housing
9-PVH	Combustion Fan Housing
10-PVH	Combustion Fan
11-PVH	Temperature Probe Housing
12-PVH	Control Board

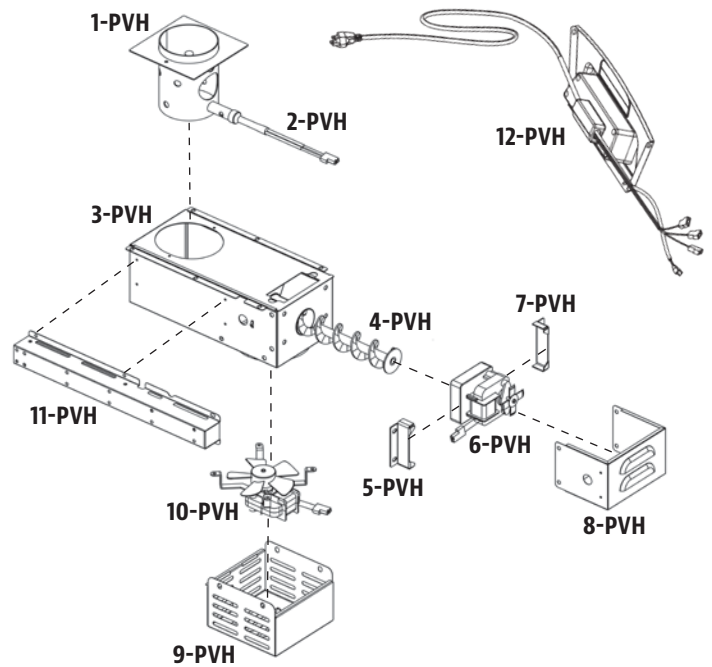

# WARRANTY

## CONDITIONS

All wood pellet smokers by Pit Boss, manufactured by Dansons, carry a limited warranty from the date of sale by the original owner. The warranty coverage begins on the original date of purchase and proof of date of purchase, or copy of original bill of sale, is required to validate the warranty. Customers will be subject to parts, shipping, and handling fees if unable to provide proof of the purchase or after the warranty has expired.

Dansons carries a five (5) year warranty against defects and workmanship on all parts, and five (5) years on electrical components. Dansons warrants that all part(s) are free of defects in material and workmanship, for the length of use and ownership of the original purchaser. Warranty does not cover damage from wear and tear, such as scratches, dents, dings, chips or minor cosmetic cracks. These aesthetic changes of the grill do not affect its performance. Repair or replacement of any part does not extend past the limited warranty beyond the five (5) years from date of purchase.

During the term of the warranty, Dansons' obligation shall be limited to furnishing a replacement for defective and/or failed components. As long as it is within the warranty period, Dansons' will not charge for repair or replacement for parts returned, freight prepaid, if the part(s) are found by Dansons' to be defective upon examination. Dansons' shall not be liable for transportation charges, labor costs, or export duties. Except as provided in these conditions of warranty, repair or replacement of parts in the manner and for the period of time mentioned heretofore shall constitute the fulfillment of all direct and derivate liabilities and obligations from Dansons to you.

Dansons takes every precaution to utilize materials that retard rust. Even with these safeguards, the protective coatings can be compromised by various substances and conditions beyond Dansons' control. High temperatures, excessive humidity, chlorine, industrial fumes, fertilizers, lawn pesticides and salt are some of the substances that can affect metal coatings. For these reasons, the warranty does not cover rust or oxidization, unless there is loss of structural integrity on the grill component. Should any of the above occur, kindly refer to the care and maintenance section to prolong the lifespan of your unit. Dansons recommends the use of a grill cover when the grill is not in use.

This warranty is based on normal domestic use and service of the grill and neither limited warranty coverage's apply for a grill which is used in commercial applications.

## EXCEPTIONS

There is no written or implied performance warranty on Pit Boss grills, as the manufacturer has no control over the installation, operation, cleaning, maintenance or the type of fuel burned. This warranty will not apply nor will Dansons or Genesis International Corporation Pty Ltd. assume responsibility if your appliance has not been installed, operated, cleaned and maintained in strict accordance with this owner's manual. Any use of gas not outlined in this manual may void the warranty. The warranty does not cover damage or breakage due to misuse, improper handling or modifications.

Neither Dansons Inc. or Genesis International Corporation Pty Ltd., accepts responsibility, legal or otherwise, for the incidental or consequential damage to the property or persons resulting from the use of this product. Whether a claim is made against Dansons Inc. or Genesis International Corporation Pty Ltd. based on the breach of this warranty or any other type of warranty expressed or implied by law, the manufacturer shall in no event be liable for any special, indirect, consequential or other damages of any nature whatsoever in excess of the original purchase of this product. All warranties by manufacturer are set forth herein and no claim shall be made against manufacturer on any warranty or representation.

Some states do not allow the exclusion or limitation of incidental or consequential damages, or limitations of implied warranties, so the limitations or exclusions set forth in this limited warranty may not apply to you. This limited warranty gives you specific legal rights and you may have other rights, which vary from state to state.

## ORDERING REPLACEMENT PARTS

To order replacement parts, please contact Genesis International Corporation Pty Ltd. at:

**service@genesiscorp.com.au | +61 8 9248 9822**

## CONTACT CUSTOMER SERVICE

Genesis International Corporation Pty Ltd. is the supplier of Pit Boss Grills in Australia and New Zealand. If you have any questions or problems, contact Bunnings Australia or Genesis International Corporation Pty Ltd. at:

**service@genesiscorp.com.au | +61 8 9248 9822**

## WARRANTY SERVICE

Contact Genesis International Corporation Pty Ltd. for repair or replacement parts. Genesis International Corporation Pty Ltd. requires proof of purchase to establish a warranty claim; therefore, retain your original sales receipt or invoice for future reference. The serial and model number of your Pit Boss grill can be found on the hopper. Record numbers below as the label may become worn or illegible.

---

MODEL

---

SERIAL NUMBER

---

DATE OF PURCHASE

---



AUTHORIZED DEALER

Our goods come with guarantees that cannot be excluded under the ACL. You are entitled to a replacement or refund for a major failure and for compensation for any other reasonably foreseeable loss or damage. You are also entitled to have the goods repaired or replaced if goods fail to be of acceptable quality and the failure does not amount to a major failure.

## ACCESSORIES SOLD SEPARATELY

Available for purchase separately. Accessories that are shown are not guaranteed to be sold in the country in which you are purchasing the product.

ITEM	DESCRIPTION
	<b>COVER</b> Form-fitting, full length cover. Heavy-duty polyester with PVC backing for long-term use. Weatherproof. Includes draw-string lock for easy tightening.
	<b>BARBECUE FLOOR MAT</b> Easy clean, UV protected. Protection for your deck. 132cm x 86cm / 52" x 34"
	<b>3-PIECE TOOL SET</b> From preparation to presentation, you are covered with these barbecue basics. <i>Dishwasher safe. Stainless steel.</i>
	<b>ROCKING PIZZA CUTTER</b> Rock the blade side to side to cut, ensuring everything stays where it belongs. <i>Hand wash. Stainless steel.</i>
	<b>3-IN-1 BURGER PRESS</b> Craft exquisite classic burgers and sliders, or go all out and build mouth-watering stuffed creations. <i>Dishwasher safe. Plastic.</i>
	<b>BACON RACK</b> Grease troughs catch all of the bacon grease, preventing flare ups and ensuring perfectly cooked bacon every time. <i>Dishwasher safe. Non-stick coating.</i>
	<b>DEFROSTING TRAY</b> Speed up the thawing process without the use of a microwave. Thaw your food in half the time using the cast aluminum makeup of the tray. <i>Hand wash. Cast aluminum.</i>

ITEM	DESCRIPTION
	<b>GRILLING APRON</b> Adjustable apron with double front pockets for grilling tools. One size. Machine washable.
	<b>GRILL GLOVE</b> Handle cast iron pots and pans without hesitation. Withstands extreme temperature of up to 475°F (246 °C).
	<b>SIGNATURE SAUCES</b> A collection of gourmet sauces to use as glaze, dip, or condiments to the natural flavors of your food.
	<b>SIGNATURE SPICES</b> A collection of gourmet seasonings to prepare and enhance the natural flavors of your food.
	<b>MEAT PROBE</b> When connected, the temperature of food is displayed by the control board.
	<b>LED FLEXIBLE GRILL LIGHT</b> Featuring 9 LED bulbs, a clamp on design, and a 12" bendable neck that allows you to adjust for maximum visibility. 3x AAA batteries required. Batteries not included

To view more accessories, visit our online store at: [www.pitboss-grills.com](http://www.pitboss-grills.com)

# RECIPES

## **SMOKED HALIBUT**

*Makes 4 Servings*

*Suggested Wood Pellet Flavor: Hickory / Cherry / Mesquite*

### **Ingredients:**

900g / 2 lbs Halibut Filets  
125 ml / ½ c. Butter  
15 ml / 1 tbsp Fresh Dill

### **Instructions:**

1. Wash filet thoroughly in cold water and lay on paper towel until water is not visible.
2. Melt a whole stick of butter and sprinkle a liberal amount of fresh dill in the melted butter. Lay filets on aluminum foil and fold a lip around edges to contain the butter. With a basting brush, brush melted butter and dill mixture on both sides of the fish filet.
3. **Preheat smoker, then adjust to 107°C / 225°F.**
4. Place fish in the smoker. Check the filets every 15 minutes for visible moist look on filets. Brush with butter and dill mix when needed. Fish should start to flake in about 45 minutes.
5. When fish flakes very easily, take out of smoker and serve.

## **SMOKED CORNISH HENS**

*Makes 4 Servings*

*Suggested Wood Pellet Flavor: Mesquite / Hickory / Competition*

### **Ingredients:**

4 whole Cornish Game Hens  
750 ml / 3 c. Mandarin Rice  
15 ml / 1 tbsp Olive Oil  
5 ml / 1 tsp Smoked Paprika  
250 ml / 1 c. Orange Marmalade

### **Instructions:**

1. **Preheat smoker, then adjust to 135-177°C / 275-350°F.**
2. Rinse Cornish hens and pat dry with paper towel. Brush Cornish hens lightly with olive oil, and sprinkle with paprika.
3. Place Cornish hens in smoker. Smoke for 45 to 60 minutes, until the drumstick meat is tender when pressed.
4. Baste with orange marmalade during last 20 minutes of cooking time. Remove from smoker and arrange on serving platter.

### **How-to make: CHICKEN GRAVY**

If you want to catch the drippings to make gravy, place the turkey on a rack inside a large aluminum foil roast pan. Add 0.6 cm / ¼" of water or broth and some seasoning into the bottom of the pan. Monitor the juices, as you may need to add more during the cooking period.

## **SMOKED BEEF BRISKET**

*Makes 4 - 6 Servings*

*Suggested Wood Pellet Flavor: Hickory / Competition*

A whole beef brisket weighs 7.25-3.62 kg / 16-18 pounds and has three separate parts: the cap, the point, and the flat. Use the flat section, as it is lean, compact, and creates nice slices when carved.

### **Ingredients:**

1 Beef Brisket  
2.2-3.6 kg / 5-8 lbs,  
Layer of fat is at least 0.6 cm / ¼" thick  
1 bottle Prepared Yellow Mustard  
75 ml / 5 tbsp Seasoning  
1 bottle Chili Sauce  
1 pack Dry Onion Soup Mix  
375 ml / 1 ½ c. Beef Broth  
40 ml / 8 tsp Black Pepper

### **Instructions:**

1. Lay out a large piece of plastic wrap on your working station. Large enough to encase the brisket. Using a sharp knife, cut a single cut on the underside of the brisket against the grain. This will aid in slicing the finished brisket, against the grain which results in a tender, melt-in-your-mouth cut. The underside is the non-fat cap side. Slather on a generous amount of prepared mustard. Rub lightly onto the entire area. Sprinkle a generous amount of seasoning onto the mustard, then again light rub into the meat. Flip the brisket over and repeat the process. Wrap the prepared brisket in the plastic wrap and refrigerate 2 to 4 hours, or overnight.
2. Prepare the basting mixture. Mix the chili sauce, dry onion soup mix, beef broth, and black pepper. Set aside.
3. **Preheat smoker, then reduce to 82-107°C / 180-225°F.**
4. Place the brisket, fat side up, in the center of the smoker. Close the cabinet door. Hot smoke until tender, about 10 to 12 hours. Baste the brisket with the basting mixture every half hour for the first 3 hours.
5. Continue the slow smoking process until the internal temperature reaches 60-66°C / 140-150°F. Remove from smoker. **Turn smoker up to 176°C / 350°F.**
6. Place the brisket into a pouch of double-layered aluminum foil. Pour 50 ml / ¼ cup of basting mixture over the brisket in the pouch. Close the pouch shut.
7. Lay foil pouch carefully on the smoker. Steam for 1 to 1 ½ hours.
8. Open the pouch, and use a meat thermometer; internal temperature should reach 91°C / 195°F. The brisket should be firm but be able to pull the meat apart with your fingers.
9. Transfer the meat to a cutting board, and let it rest for 10 minutes. Thinly slice across the grain to serve.

## SMOKED PRIME RIB ROAST

Makes 6 - 8 Servings

Suggested Wood Pellet Flavor: Hickory / Pecan / Competition

### Ingredients:

2 lbs	Beef Prime Rib Roast
	<small>0.9 kg / 2 lbs</small>
10 cloves	Garlic (minced)
45 ml / 2 tbsp	Seasoning
10 ml / 2 tsp	Salt
10 ml / 2 tsp	Pepper

### Instructions:

1. **Preheat smoker, then adjust to 135°C / 275°F.**
2. With the fat-side of the meat facing up, tie one end of string or twine firmly around one side of the roast. Continue to loop and tie the rest of the roast, making an attractive presentation.
3. Thoroughly wash the roast and pat dry with paper towel.
4. Liberally, season the entire roast with garlic, salt, pepper, and seasoning. Let the roast sit for 10 minutes so seasoning adheres.
5. Place roast in smoker. Smoke for 45 to 60 minutes, until the internal temperature has reached 51°C / 125°F. Use a meat probe to best monitor the middle of the roast.
6. Carefully, remove roast from smoker and cover with foil. The meat will continue to rise by another 3°C / 5°F to a final product of 54°C / 125°F to a perfect medium rare. Let the meat rest for 10 minutes before slicing.

## SMOKED RIBS

Makes 4 - 6 Servings

Suggested Wood Pellet Flavor: Hickory / Apple / Competition

### Ingredients:

1.3-1.8 kg / 3-4 lbs	Ribs
	<small>Meaty pork spare ribs / loin back ribs</small>
5 ml / 1 tsp	Salt
5 ml / 1 tsp	Pepper

### Instructions:

1. **Preheat smoker, then reduce to 82-107°C / 180-225°F.**
2. Take ribs out of wrapper and drain all liquid off of the ribs and then wash in cold water.
3. Place on cutting board and cut away any excess fat or skin from the bottom of ribs. Turn ribs with bone side up. Prepare ribs by peeling off the tough layer of skin (membrane) on the back side. Season the ribs with salt and pepper, to taste.
4. Place rib bone side down in smoker.
5. After one hour, turn the rib over with bone side up and cook for one hour. After 2 1/2 hours, depending on the color of the rib you like, pour a one inch wide strip of your favorite BBQ sauce down the length of the rib and wrap tightly in aluminum foil. Place back in smoker and check every 15 to 20 minutes to see if the rib bones separate by using your finger to pull them apart. If they

pull apart with ease your ribs are done; internal temperature of your ribs should be at 170°F.

6. Take out of smoker and let stand on serving platter until cool enough to eat.

### Variation: MEMPHIS-DRY METHOD

Turn smoker up to maximum temperature (204°C / 400°F). Place ribs back on the smoker and season with a dry seasoning or rub for 5-8 minutes. Remove from smoker and serve.

## SMOKED STUFFED PORK TENDERLOIN

Makes 4 - 8 Servings

Suggested Wood Pellet Flavor: Apple / Hickory / Cherry

### Ingredients:

1 whole	Pork Tenderloin
	<small>3.6 kg / 8 lbs</small>
1 jar	Salsa
15 ml / 1 tbsp	Chili Powder
15 ml / 1 tbsp	Brown Sugar
5 ml / 1 tsp	Smoked Paprika
45 ml / 3 tbsp	Honey (warmed)
Pinch	Ground Cinnamon

### Instructions:

1. **Preheat smoker, then adjust to 107-135°C / 225-275°F.**
2. Remove the pork tenderloin from packaging, rinse with cold water and pat the exterior dry with paper towel.
3. Place a piece of plastic wrap on a cutting board, then place the pork tenderloin on top and cut the meat  $\frac{3}{4}$  of the way through. Open the pork loin so it lays flat, and place a second piece of plastic wrap on top. Use a meat tenderizer or rolling pin to pound the meat until flattened.
4. Arrange salsa down center of pork tenderloin. Fold in the sides and roll-up the pork tenderloin (like a cinnamon bun) carefully to distribute salsa evenly. Using twine, tie the pork tenderloin at both ends and the middle to secure.
5. In a bowl, combine the chili powder, brown sugar, smoked paprika, and ground cinnamon. Mix well. Brush the pork tenderloin with the warmed honey. Sprinkle the mixture over the entire tenderloin.
6. When the pork is fully coated, place inside the smoker. Smoke the tenderloin for 2 ½ to 3 hours, or until the internal temperature of pork has reached 62°C / 145°F.
7. Take out of smoker, slice and serve immediately.

## **SMOKED CHICKEN**

*Makes 2 - 6 Servings*

*Suggested Wood Pellet Flavor: Hickory / Apple / Competition*

### **Ingredients:**

1 whole Chicken  
1.8-2.7 kg / 4-6 lbs  
45 ml / 3 tbsp Seasoning or Rub

### **Instructions:**

1. **Preheat smoker, then adjust to 107-135°C / 225-275°F.**
2. Take chicken parts out of package and wash thoroughly and place on paper towel to dry.
3. Sprinkle seasoning or rub on both sides of chicken parts.
4. Place chicken in smoker, breast side up. After 30 minutes, turn chicken over. With your meat probe, check the internal temperature by pushing temperature probe into the meat nearest the bone. When internal temperature reaches 82°C / 180°F, the chicken is done.

**TIP: You may brush your favorite BBQ sauce on the chicken during the last 15 minutes of your cooking process to heat it up.**

5. Using tongs, carefully remove the chicken from the smoker. Let rest for five minutes. Carve chicken and serve.

### **Variation: FLAVORED MARINADE IN WATER PAN**

Use the same instructions as above, but substitute half the water in the water pan with a can of your favorite non-diet cola, fruit juice, or water with additional seasoning.

## **SMOKED SAUSAGE WITH MANGO CHUTNEY**

*Makes 4 - 6 Servings*

*Suggested Wood Pellet Flavor: Hickory / Apple / Competition*

### **Ingredients:**

0.9 kg / 2 lbs Italian Sausage (hot or mild)  
2 whole Mangoes (finely chopped)  
10 ml / 2 tsp Fresh Parsley (minced)  
15 ml / 1 tbsp Red Pepper (diced)  
10 ml / 2 tsp Honey  
½ Red Onion (diced)  
½ bulb Fennel (diced)  
5 ml / 1 tsp Lime Juice  
Pinch Salt

### **Instructions:**

1. **Preheat smoker, then reduce to 82-107°C / 180-225°F.**
2. Place sausages on cooking grids, spaced evenly apart. Smoke for 25-30 minutes until cooked.
3. Combine all remaining ingredients to make the chutney. Chill until ready to serve.
4. Remove sausages from smoker. Slice sausage diagonally, then serve with side of chutney.

## **WHOLE SMOKED TURKEY**

*Feeds a small army - leftovers are great!*

*Suggested Wood Pellet Flavor: Hickory / Cherry / Competition*

### **Ingredients:**

1 whole Turkey (thawed)  
9-11.3 kg / 20-25 lbs  
60 ml / 4 tbsp Seasoning or Rub  
5 ml / 1 tsp Smoked Paprika  
45 ml / 3 tbsp Butter

### **Instructions:**

1. **Preheat smoker, then adjust to 135-177°C / 275-350°F.**
2. Remove the turkey neck and giblets. Rinse turkey thoroughly and pat the exterior dry with paper towel.
3. In a small bowl, mix butter, ¼ of the seasoning and paprika together to form a paste. Gently insert your hand between the outer skin and the breast meat. Rub paste into the meat.
4. With the remaining seasoning, rub the outer surface of the turkey.
5. Place turkey, breast side up, in center of smoker, and smoke until turkey is tender and golden brown; internal temperature should reach 82°C / 180°F in the thickest part of the thigh and 77°C / 170°F in the breast.
6. Remove turkey, cover with foil and let rest for 10 minutes before carving.

### **How-to make: TURKEY GRAVY**

If you want to catch the drippings to make gravy, place the turkey on a rack inside a large aluminum foil roast pan. Add 0.6 cm / ¼" of water or broth and some seasoning into the bottom of the pan. Monitor the juices, as you may need to add more during the cooking period.





# IMPORTANT

For all questions, inquiries, or customer support, please contact Genesis International Corporation Pty Ltd.

+61 8 9248 9822 | [service@genesiscorp.com.au](mailto:service@genesiscorp.com.au)



**WARNING:** This product can expose you to chemicals including carbon monoxide, which is a combustion by-product known to cause cancer, birth defects or other reproductive harm. For more information, go to:

[WWW.PRODUCTSAFETY.GOV.AU/NEWS/CARBON-MONOXIDE-SAFETY](http://WWW.PRODUCTSAFETY.GOV.AU/NEWS/CARBON-MONOXIDE-SAFETY)

MADE IN CHINA

[WWW.PITBOSS-GRILLS.COM](http://WWW.PITBOSS-GRILLS.COM)



780190128AUM

