

CORNER SOFA

Assembly Instruction

Item No: 3192138

A	Back Frame	1
B	Seat Frame	1
C	Bolt M6*42	5
D	Washer Ø*13*Ø6.5*1.0mm	5
E	Allen Key	1

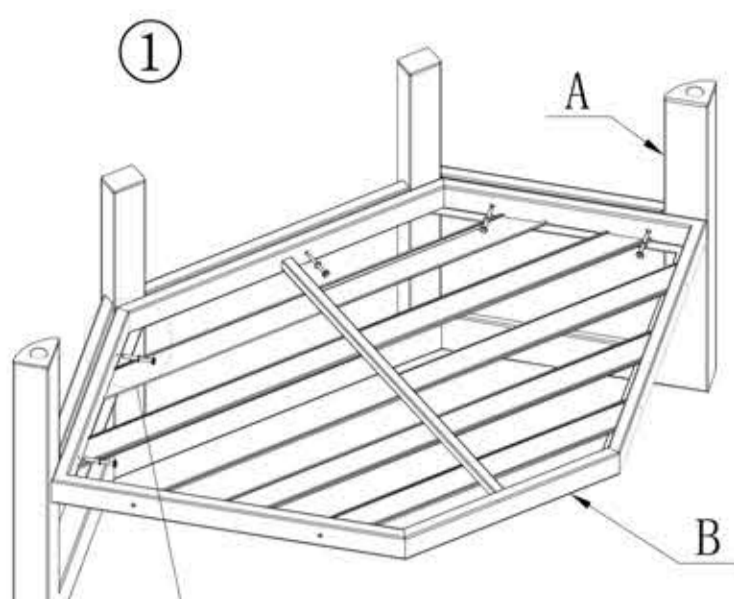

Step 1: Secure the back frame (A) and seat frame (B) with bolt (C) and washer (D). Loosely secure with Allen Key (E)

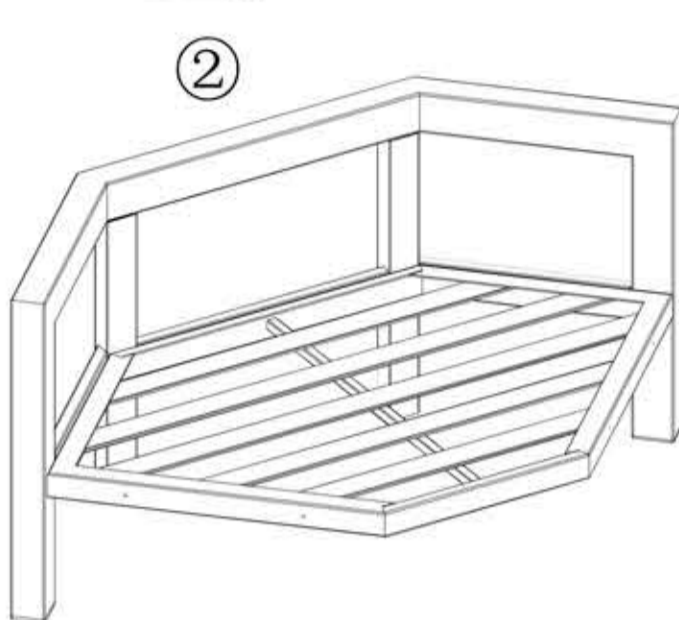
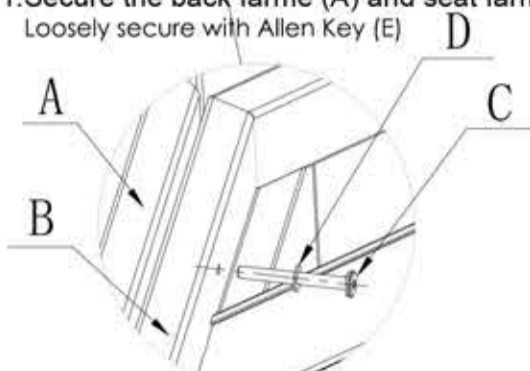

Important Notice:

Do not fully tighten screws until the seat is fully assembled.

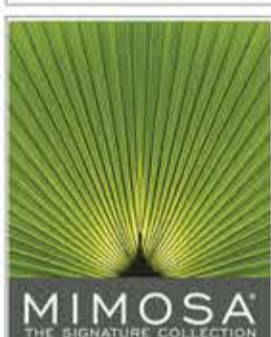

COFFEE TABLE

A	Leg Frame	2
B	Table Frame	1
C	Glass	1
D	Bolt M6*35	6
E	Bolt M6*25	8
F	Washer Ø*13*Ø6.5*1.0mm	14
G	Bolt Cover	14
H	Allen Key	1

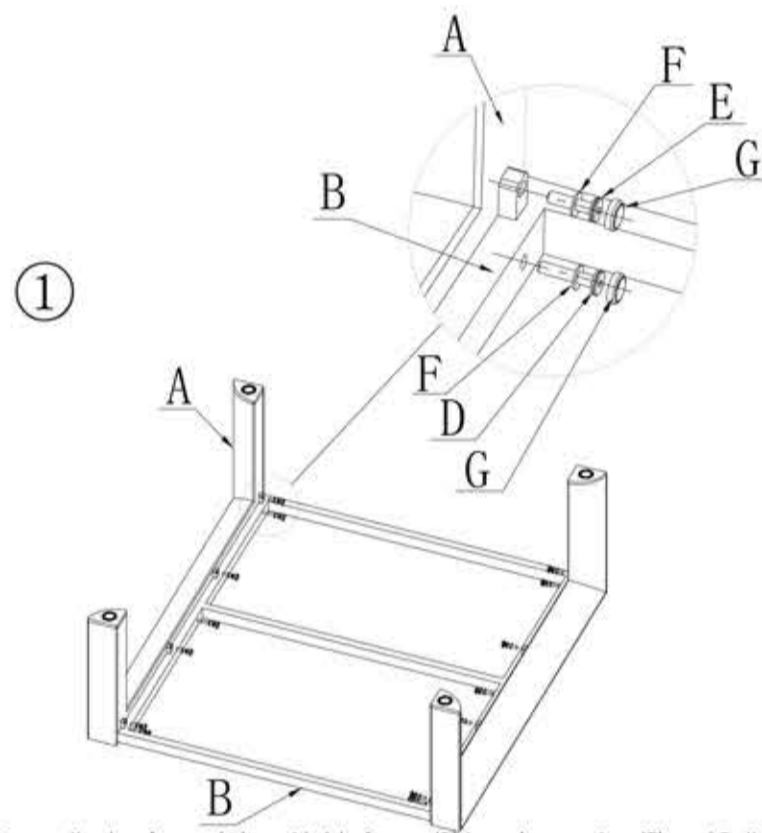

Step 1: Secure the leg frame (A) and table frame (B) by using washer (F) and Bolt (E/D). Loosely secure with Allen Key (E)

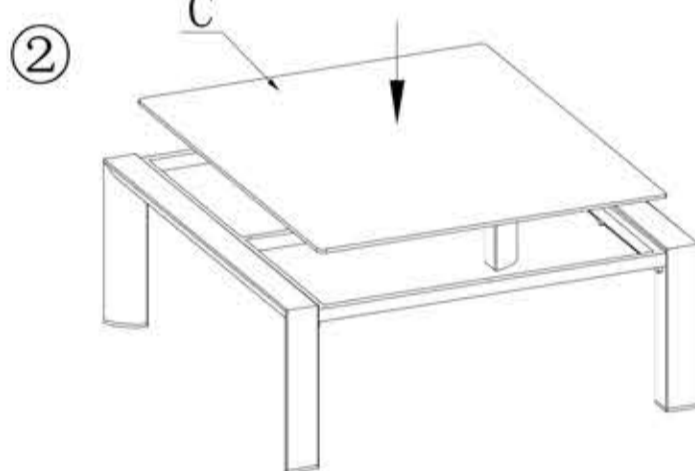

Step 2: Carefully place the glass (C) on the table frame (B).



Step 3: After securing all the bolts add the bolt cover (G) to conceal the bolt heads.

Important Notice:

Do not fully tighten screws until the table is fully assembled.



2 SEATER SOFAS

A	Corner Seat	1
B	Left arm rest sofa	1
C	Right arm rest sofa	1
D	Bolt M6*60	4
E	Washer Ø*13*Ø6.5*1.0mm	8
F	M6 nut	4
G	Spanner	1
H	Allen Key	1

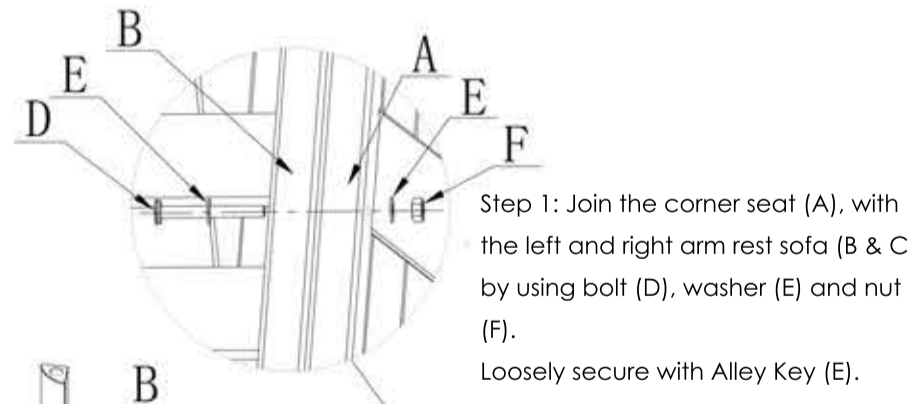

Step 1: Join the corner seat (A), with the left and right arm rest sofa (B & C), by using bolt (D), washer (E) and nut (F). Loosely secure with Alley Key (E).

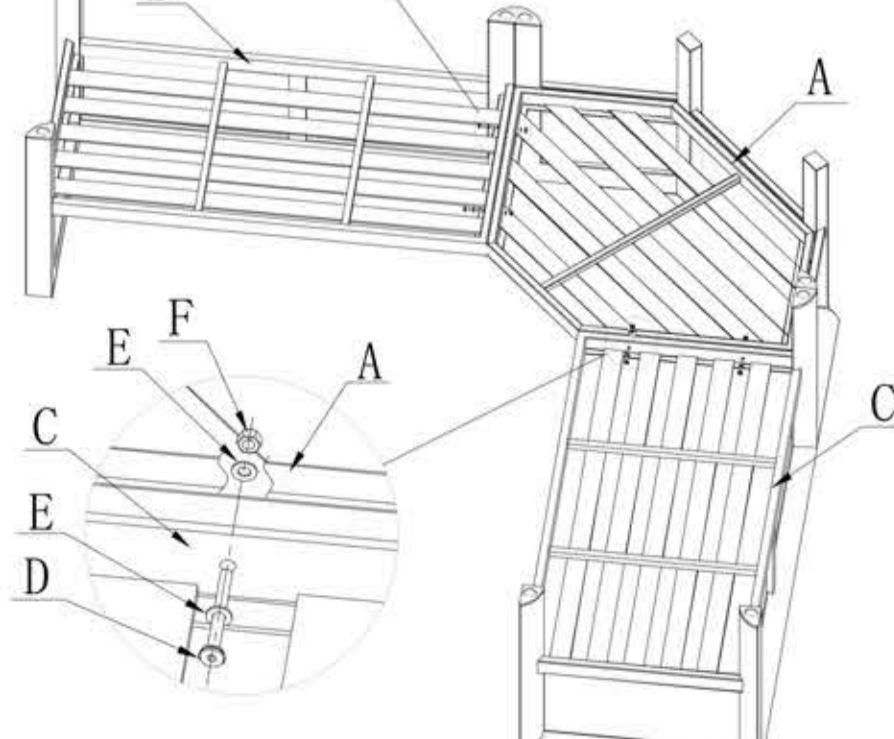

Step 2: Tightly secure all nuts.

Important Notice:

Do not fully tighten screws until the seat is fully assembled.