

ozito

METAL CUT-OFF SAW

2300W

INSTRUCTION MANUAL

SPECIFICATIONS

Motor:	2300W
Input:	230-240V-50Hz
No Load Speed:	4,400/min
Cutting Disc	
Max. Diameter:	356 x 3mm (14" x 1/8")
Arbour Size:	25.4mm
Cutting Angle Capacity:	0-45° Left, 0-30° Right
Max. Cutting Capacities:	Round steel 130mm Square steel 120mm Rectangle steel 120x130mm Angle steel 140x140mm
Weight:	16.8kg

ozito.com.au

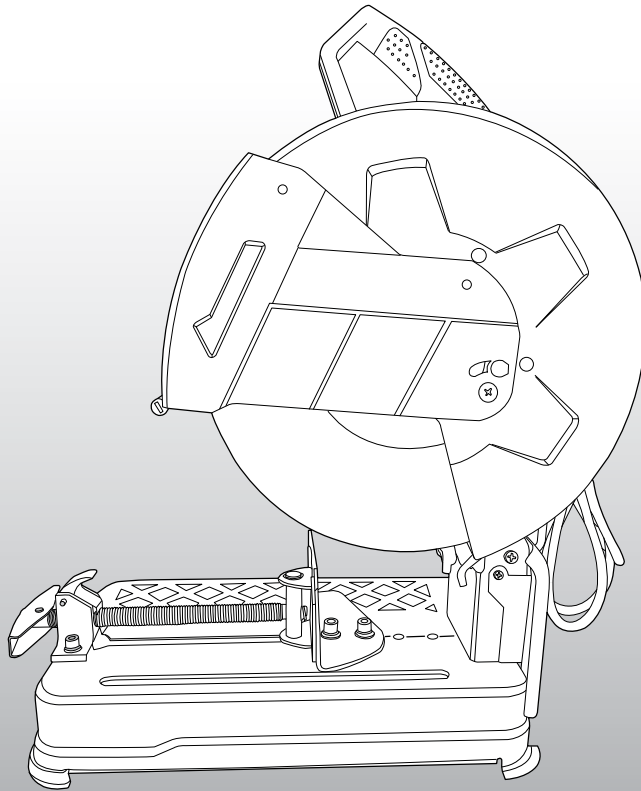

WHAT'S IN THE BOX

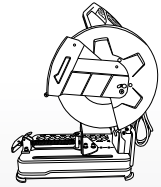

Metal Cut-off Saw

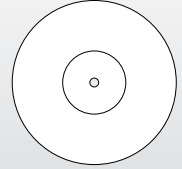

Cutting Disc (fitted)



Hex Key

3 YEAR REPLACEMENT WARRANTY

MCS-2355

WARRANTY

IN ORDER TO MAKE A CLAIM UNDER THIS WARRANTY YOU MUST RETURN THE PRODUCT TO YOUR NEAREST BUNNINGS WAREHOUSE WITH YOUR BUNNINGS REGISTER RECEIPT. PRIOR TO RETURNING YOUR PRODUCT FOR WARRANTY PLEASE TELEPHONE OUR CUSTOMER SERVICE HELPLINE:

Australia 1800 069 486

New Zealand 0508 069 486

TO ENSURE A SPEEDY RESPONSE PLEASE HAVE THE MODEL NUMBER AND DATE OF PURCHASE AVAILABLE. A CUSTOMER SERVICE REPRESENTATIVE WILL TAKE YOUR CALL AND ANSWER ANY QUESTIONS YOU MAY HAVE RELATING TO THE WARRANTY POLICY OR PROCEDURE.

The benefits provided under this warranty are in addition to other rights and remedies which are available to you at law.

Our goods come with guarantees that cannot be excluded at law. You are entitled to a replacement or refund for a major failure and for compensation for any other reasonably foreseeable loss or damage. You are also entitled to have the goods repaired or replaced if the goods fail to be of acceptable quality and the failure does not amount to a major failure.

Generally you will be responsible for all costs associated with a claim under this warranty, however, where you have suffered any additional direct loss as a result of a defective product you may be able to claim such expenses by contacting our customer service helpline above.

3 YEAR REPLACEMENT WARRANTY

Your product is guaranteed for a period of **36 months from the original date of purchase**. If a product is defective it will be replaced in accordance with the terms of this warranty. Warranty excludes consumable parts, for example: carbon brushes, spanners, cutting disc, accessories.

WARNING

The following actions will result in the warranty being void.

- If the tool has been operated on a supply voltage other than that specified on the tool.
- If the tool shows signs of damage or defects caused by or resulting from abuse, accidents or alterations.
- Failure to perform maintenance as set out within the instruction manual.
- If the tool is disassembled or tampered with in any way.
- Professional, industrial or high frequency use.

KNOW YOUR PRODUCT

METAL CUT-OFF SAW

- | | |
|--------------------|-----------------------------|
| 1. Vice handle | 9. Main handle |
| 2. Lower guard | 10. Spindle lock button |
| 3. Cutting disc | 11. Lock down pin |
| 4. Upper guard | 12. Depth stop |
| 5. Carry handle | 13. Base |
| 6. Rubber feet | 14. Fence |
| 7. Lock-off button | 15. Vice |
| 8. Trigger switch | 16. Quick release vice lock |

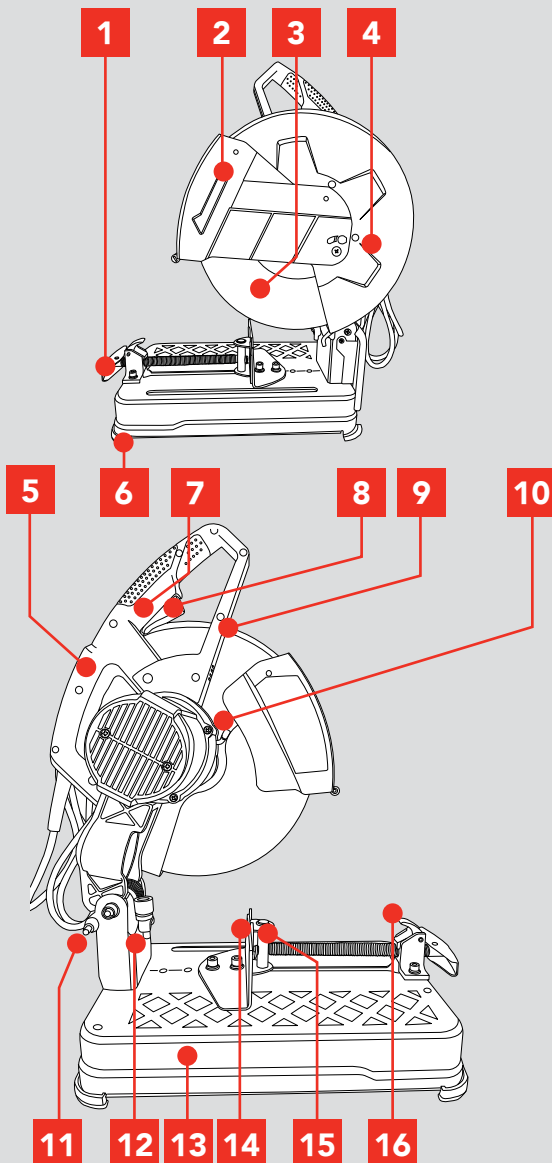

ONLINE MANUAL

Scan this QR Code with your mobile device to take you to the online manual.



SETUP & PREPARATION

1. ADJUSTMENTS

WARNING! ALWAYS ENSURE THAT THE METAL CUTTING SAW IS SWITCHED OFF AND UNPLUGGED FROM THE POWER SUPPLY BEFORE MAKING ANY ADJUSTMENT.

Your Metal Cut-Off Saw is used for cutting steel such as pipe, box section, rectangular, angle iron and steel bars. The saw can cut at angles from 0 to 45° left & 0 to 30° right, it features a three position fence that permits an extended cutting range. The quick release vice allows fast adjustment whilst the lock-off button prevents accidental operation. It is intended for DIY use only.

Adjusting the vice

WARNING! ENSURE THE VICE SECURING BOLTS AND VICE IS FIRMLY TIGHTENED BEFORE USE TO PREVENT THE WORK PIECE MOVING AND RISK OF PERSONAL INJURY.

The vice can be adjusted quickly by lifting the quick release vice lock and pushing forward or pulling back on the vice handle.

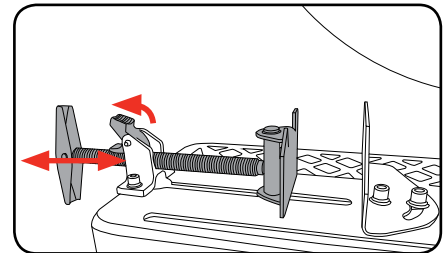

1. Place your work piece in between the fence and vice.

2. Lift the quick release vice lock and push the vice forward.

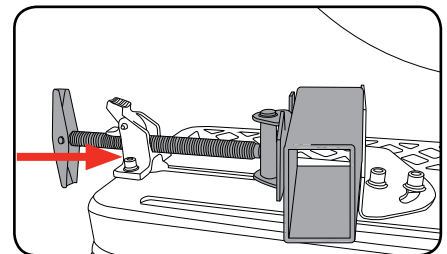

3. Once the vice hits the work piece push down the quick release vice lock.

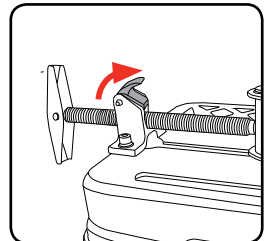

4. Rotate the vice handle in a clockwise direction to secure the work piece in position.

5. To remove an object from the vice, rotate the vice handle in an anti-clockwise direction until the vice jaws are loose. The work piece can now be removed.

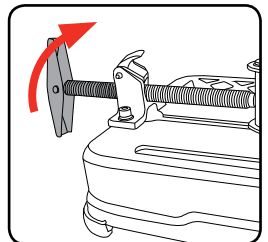

Note: The quick release vice lock cannot be lifted until the vice jaws have been loosened.

3 YEAR REPLACEMENT WARRANTY

Adjusting the cutting angle

1. To change the cutting angle loosen the two bolts securing the fence using the hex key supplied.

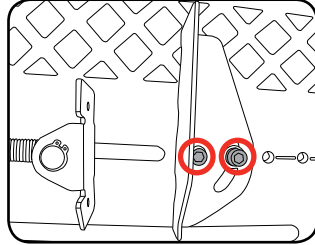

2. Move the rear fence to the desired angle using the scale as a guide.

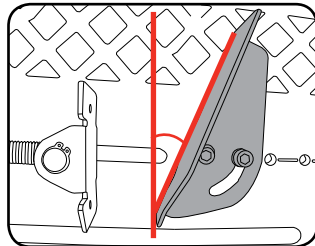

3. Tighten the two bolts to secure the fence in position.

CAUTION! ONLY PERFORM ANGLE CUTS WHEN THE FENCE IS SET AT THE MOST FORWARD POSITION (REFER TO ADJUSTING THE FENCE)

Note: For accurate cuts, test the cutting angle on some similar scrap material and adjust the angle to suit your requirements. The scale is only a guide.

Adjusting the fence

The spacing between the vice and the fence as supplied is 170mm.

When cutting wider materials the rear fence will need to be adjusted to the rear position. When cutting narrow work pieces the fence should be positioned in the most forward position.

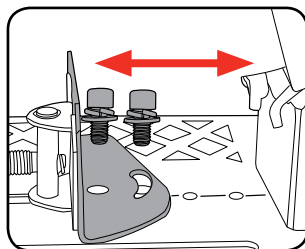
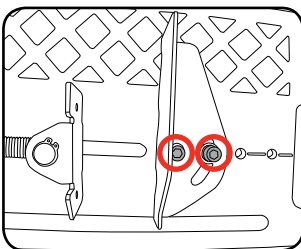

1. To adjust, loosen and remove the two bolts securing the fence using the Hex key.
2. Move the fence backwards or forwards to one of the other two fixing positions.

CAUTION! NARROW WORK PIECES MAY NOT BE SECURED SAFELY WHEN USING AN INTERVAL TOO WIDE FOR THE FENCE. ENSURE THAT THE FENCE IS SET TO THE MOST FORWARD POSITION THAT ALLOWS THE WORK PIECE TO BE CLAMPED SECURELY.

3. Tighten the two bolts to secure the fence in position.

Depth stop

Note: Ensure that the depth stop is adjusted to the correct height before commencing operation.

The adjustable depth stop is threaded into the base of the machine at the rear.

The travel of the cutting disc can be controlled by raising and lowering the depth stop bolt.

This feature is particularly useful to prevent contact with the work bench surface when a new disc is fitted or to increase disc travel as the disc wears.

The depth stop should be checked and adjusted every time a new disc is fitted.

1. Loosen the depth stop with the hex key supplied.

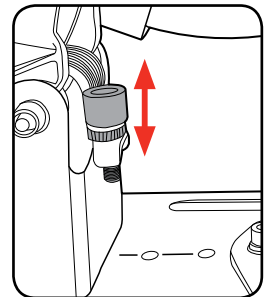

2. Increase or decrease the height of the depth stop.

3. Tighten the depth stop knurled lock nut with your fingers.

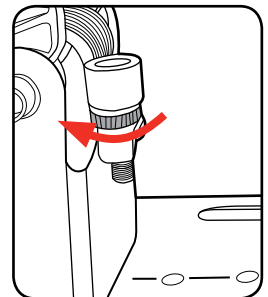

WARNING! THE DO NOT REMOVE OR OPERATE WITHOUT THE DEPTH STOP!

OPERATION

2. STARTING AND STOPPING

WARNING! THE POWER SUPPLY FOR THIS PRODUCT SHOULD BE PROTECTED BY A RESIDUAL CURRENT DEVICE RATED AS 30mA OR LESS.

Turning ON and OFF

To prevent accidental starting, the metal cut-off saw is designed with a dual action switch.

Note: The metal cut-off saw can be started by pushing either the lock-off button or trigger switch in any order. Ensure the instructions below are adhered to.

1. Plug the cordset into the mains socket.

2. Push the lock-off button and pull the trigger switch to start the tool.

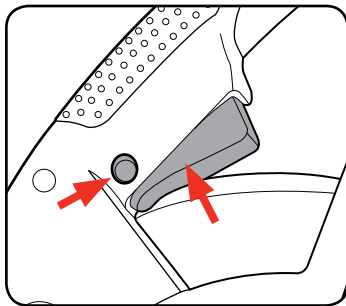

3. To stop the tool release the trigger switch.

4. When you release the trigger switch, the machine turns off and the lock-off button re-engages to prevent accidental operation.

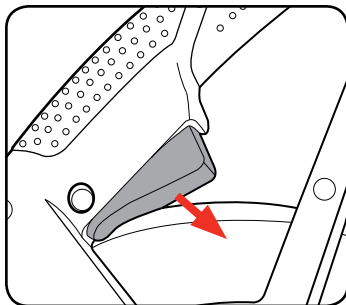

WARNING! THE CUTTING DISC WILL CONTINUE TO RUN, AS IT SLOWS DOWN, FOR A SHORT PERIOD OF TIME AFTER THE TRIGGER SWITCH HAS BEEN RELEASED.

3. OPERATING

Cutting

1. Make all adjustments including setting the vice, fence position and fence angle.

2. Ensure that the work piece is fully secured before starting metal cutting operations.

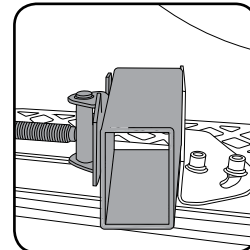

CAUTION: ENSURE YOU ARE WEARING THE APPROPRIATE SAFETY GEAR INCLUDING EYE PROTECTION AND HEARING PROTECTION.

3. Check that the cutting disc, upper guard, lower guard, head lock pin, blade access cover and the metal cutting saw is in good condition.

4. Plug the cordset into the mains socket.

5. Push the lock-off button and pull the trigger switch to start the tool.

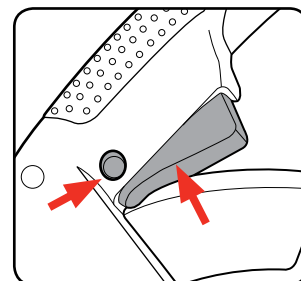

CAUTION: ALLOW THE BLADE TO REACH MAXIMUM SPEED BEFORE PERFORMING ANY CUTS.

6. Using the main handle bring the cutting disc down onto the work piece and allow it to cut its way through the work piece without excessive force. Too much down force will overheat cutting disc and reduce cutting ability or overload the saw.

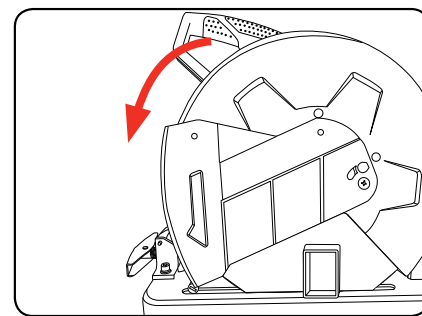

7. Once the cut is finished, raise the main handle to clear the cutting disc from the work piece, release the trigger switch and the cut off saw will stop.

WARNING! THE CUTTING DISC WILL CONTINUE TO RUN, AS IT SLOWS DOWN, FOR A SHORT PERIOD OF TIME AFTER THE TRIGGER SWITCH HAS BEEN RELEASED.

4. HINTS & TIPS

Some helpful tips when using the metal cutting saw

- Cutting disc selection. The cutting disc must match the material to be cut. There are a wide variety of cutting discs and careful selection will assist in the correct and safe operation of the saw. For example, select a bar cutting disc for cutting solid metal section and a metal stud cutting disc for cutting steel sections. General purpose metal cutting discs are also available but where possible it is better to use the correct cutting disc for the task being performed.
- The abrasive cutting discs wear so as to constantly expose to the material being cut clean and sharp cutting edges. This is normal.
- During the cutting operation apply a constant and even pressure to the main handle. The cutting disc should be constantly cutting, and sufficient pressure needs to be applied to keep the cutting action going. If insufficient pressure is applied, the wheel has a tendency to clog, and the cutting edges of the disc become blunt and the cutting process reduces considerably. This is called glazing of the wheel and is due to the incorrect cutting disc for the material being cut, or the cutting rate being too slow.
- Do not overload the saw. The saw should run during the cutting operation at close to full speed. Too much pressure being applied to the tool will slow the motor and can cause motor failure.
- Too much pressure being applied to the tool can also cause the cutting disc to cut on an angle. Ensure the beginning of the cut is a gradual start and apply the firm and constant pressure as the cut gets deeper.
- When cutting sections, always try and cut the sections so as the actual cutting length is as short as possible through the section. For example, angle iron has two sections to be cut. If the material is cut where both sections are cut at once, it is better for the cutting action than trying to cut on thin section and then a long length cut for the next section. The longer the length of cut, the more chance of the cutting disc glazing and motor overload.

Note: As the disc wears the cutting capacity will decrease and the depth stop may need to be adjusted.

5. REPLACING A DISC

WARNING! ALWAYS ENSURE THAT THE SAW IS SWITCHED OFF AND UNPLUGGED FROM THE POWER SUPPLY BEFORE INSTALLING OR REMOVING A DISC.

WARNING! ENSURE THE CUTTING DISC MAXIMUM CUTTING SPEED IS RATED HIGHER THAN THE RATED SPEED OF THE METAL CUTTING SAW.

CAUTION: ENSURE THE DEPTH STOP IS ADJUSTED TO THE CORRECT HEIGHT PRIOR TO ASSEMBLY OF THE NEW CUTTING DISC.

1. Swing the lower guard away to reveal the cutting disc bolt and flange.

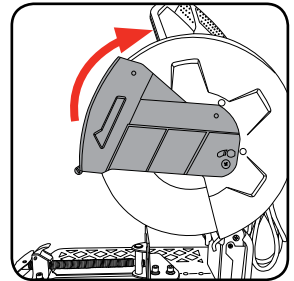

2. Push the spindle lock button and rotate the cutting disc until the spindle lock button engages.

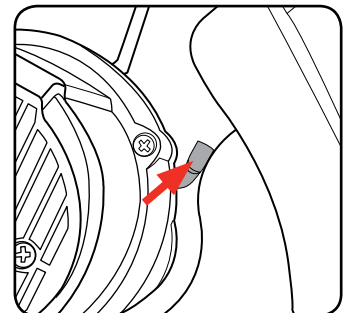

3. Whilst holding the spindle lock button use the hex key (supplied) to remove the cutting disc bolt

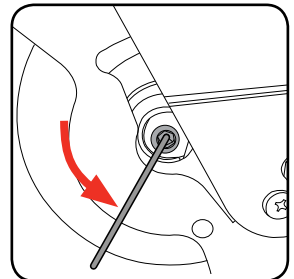

Note: To remove the cutting disc bolt, rotate anti-clockwise.

MAINTENANCE

5. REPLACING A DISC cont.

4. Remove the cutting disc bolt, washer and outer flange.

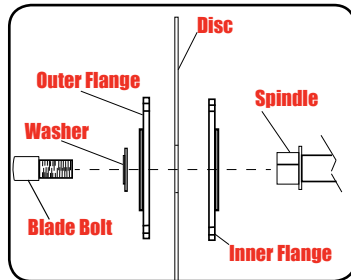

5. Clean any grinding dust from the inner flange and, after checking that it is in good condition, mount a new cutting disc onto the spindle.

CAUTION! CHECK THE CUTTING DISC FOR CRACKS AND DAMAGE PRIOR TO ASSEMBLY.

6. Replace the outer flange, washer and cutting disc bolt.

7. Whilst holding the spindle lock button use the hex key to tighten the cutting disc bolt in a clockwise direction.

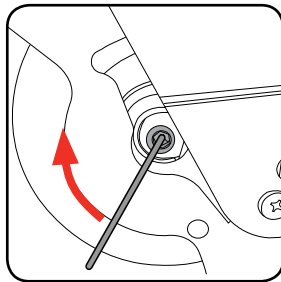

8. Turn the new cutting disc by hand, ensuring that it rotates fully and does not vibrate or oscillate excessively.

6. GENERAL MAINTENANCE

- Keep the ventilation slots of the metal cut-off saw clean at all times and prevent any foreign matter from entering.
- If the housing of the metal cut-off saw requires cleaning do not use solvents but a moist soft cloth only.
- The grease in the gearbox will require replacement/replenishment after extensive use of the saw. Please see a power tool repairer to provide this service.
- Blow dust from the saw through the rear ventilation slots with compressed air periodically to ensure a dust free tool.

WARNING! MAKE SURE THE METAL CUT-OFF SAW OPERATES PROPERLY. PERIODICALLY CHECK SCREWS AND BOLTS FOR TIGHTNESS. APPLY DRY LUBRICANT MONTHLY TO THE MOVING PARTS TO EXTEND MACHINE LIFE.

Carbon brushes

When the carbon brushes wear out, the metal cut-off saw will spark and/or stop. Discontinue use as soon as this happens.

They should be replaced prior to recommencing use of the cut-off saw. Carbon brushes are a wearing component of the cut-off saw and therefore not covered under warranty.

Continuing to use the cut-off saw when carbon brushes need to be replaced may cause permanent damage to the tool.

Carbon brushes will wear out after many uses but when the carbon brushes need to be replaced take the cut-off saw to an electrician or a power tool repairer for a quick and low cost replacement. Always replace both carbon brushes at the same time.

Note: Ozito Industries will not be responsible for any damage or injuries caused by the repair of the cut-off saw by an unauthorised person or by mishandling of the cut-off saw.



Transporting the tool

The head lock pin is located on the left side of motor arm to allow the tool to be transported safely.

To store or transport the tool, lower the main handle and push in the head lock pin.

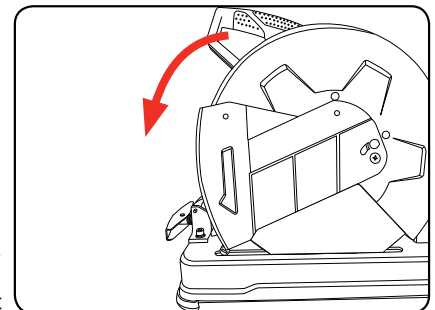





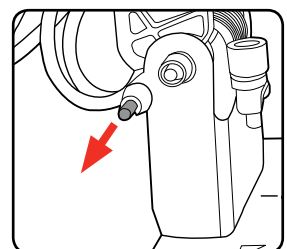





To release the head lock pin, push down on the main handle and pull out the head lock pin.

Note: The saw motor head arm is fitted with a high tension spring. Keep hand pressure on the main handle and slowly allow the saw head to raise.



DESCRIPTION OF SYMBOLS

V	Volts	Hz	Hertz
~	Alternating current	W	Watts
/min	Revolutions or reciprocation per minute	n_o	No load speed
	Protective Earthed		Regulator compliance mark
	Disconnect from power supply when performing maintenance		Wear eye protection
	Do not use in raining		Wear breathing protection
	Read instruction manual		Wear hearing protection
	Double insulation		
	Note the rotating direction of the cutting disc!		

CARING FOR THE ENVIRONMENT



Power tools that are no longer usable should not be disposed of with household waste but in an environmentally friendly way. Please recycle where facilities exist. Check with your local council authority for recycling advice.



Recycling packaging reduces the need for landfill and raw materials. Reuse of recycled material decreases pollution in the environment. Please recycle packaging where facilities exist. Check with your local council authority for recycling advice.

SPARE PARTS

Limited spare parts are available subject to availability. Please contact your local Bunnings Special Orders Desk to order the required spare parts.

For further information, or any parts not listed here, visit www.ozito.com.au or contact Ozito Customer Service:

Australia 1800 069 486

New Zealand 0508 069 486

E-mail: enquiries@ozito.com.au

ELECTRICAL SAFETY

 **WARNING!** When using mains-powered tools, basic safety precautions, including the following, should always be followed to reduce risk of fire, electric shock, personal injury and material damage.

Read the whole manual carefully and make sure you know how to switch the tool off in an emergency, before operating the tool.
Save these instructions and other documents supplied with this tool for future reference.

The electric motor has been designed for 230V and 240V only. Always check that the power supply corresponds to the voltage on the rating plate.

Note: The supply of 230V and 240V on Ozito tools are interchangeable for Australia and New Zealand.



This tool is double insulated therefore no earth wire is required.

Using an Extension Lead

Always use an approved extension lead suitable for the power input of this tool. Before use, inspect the extension lead for signs of damage, wear and ageing. Replace the extension lead if damaged or defective.

When using an extension lead on a reel, always unwind the lead completely. Use of an extension lead not suitable for the power input of the tool or which is damaged or defective may result in a risk of fire and electric shock.

GENERAL POWER TOOL SAFETY WARNINGS

 **WARNING!** Read all safety warnings and all instructions. Failure to follow the warnings and instructions may result in electric shock, fire and/or serious injury. **Save all warnings and instructions for future reference. The term "power tool" in the warnings refers to your mains-operated (corded) power tool or battery-operated (cordless) power tool.**

1. Work area safety

- Keep work area clean and well lit.** Cluttered or dark areas invite accidents.
- Do not operate power tools in explosive atmospheres, such as in the presence of flammable liquids, gases or dust.** Power tools create sparks which may ignite the dust or fumes.
- Keep children and bystanders away while operating a power tool.** Distractions can cause you to lose control.

2. Electrical safety

- Power tool plugs must match the outlet. Never modify the plug in any way. Do not use any adapter plugs with earthed (grounded) power tools.** Unmodified plugs and matching outlets will reduce risk of electric shock.
- Avoid body contact with earthed or grounded surfaces, such as pipes, radiators, ranges and refrigerators.** There is an increased risk of electric shock if your body is earthed or grounded.
- Do not expose power tools to rain or wet conditions.** Water entering a power tool will increase the risk of electric shock.
- Do not abuse the cord. Never use the cord for carrying, pulling or unplugging the power tool. Keep cord away from heat, oil, sharp edges or moving parts.** Damaged or entangled cords increase the risk of electric shock.
- When operating a power tool outdoors, use an extension cord suitable for outdoor use.** Use of a cord suitable for outdoor use reduces the risk of electric shock.
- If operating a power tool in a damp location is unavoidable, use a residual current device (RCD) protected supply.** Use of an RCD reduces the risk of electric shock.

3. Personal safety

- Stay alert, watch what you are doing and use common sense when operating a power tool. Do not use a power tool while you are tired or under the influence of drugs, alcohol or medication.**
A moment of inattention while operating power tools may result in serious personal injury.
- Use personal protective equipment. Always wear eye protection.** Protective equipment such as dust mask, non-skid safety shoes, hard hat, or hearing protection used for appropriate conditions will reduce personal injuries.
- Prevent unintentional starting. Ensure the switch is in the off-position before connecting to power source and/or battery pack, picking up or carrying the tool.** Carrying power

tools with your finger on the switch or energising power tools that have the switch on invites accidents.

- Remove any adjusting key or wrench before turning the power tool on.**
A wrench or a key left attached to a rotating part of the power tool may result in personal injury.
 - Do not overreach. Keep proper footing and balance at all times.** This enables better control of the power tool in unexpected situations.
 - Dress properly. Do not wear loose clothing or jewellery. Keep your hair, clothing and gloves away from moving parts.** Loose clothes, jewellery or long hair can be caught in moving parts.
 - If devices are provided for the connection of dust extraction and collection facilities, ensure these are connected and properly used.** Use of dust collection can reduce dust-related hazards.
- ## 4. Power tool use and care
- Do not force the power tool. Use the correct power tool for your application.** The correct power tool will do the job better and safer at the rate for which it was designed.
 - Do not use the power tool if the switch does not turn it on and off.** Any power tool that cannot be controlled with the switch is dangerous and must be repaired.
 - Disconnect the plug from the power source and/or the battery pack from the power tool before making any adjustments, changing accessories, or storing power tools.** Such preventive safety measures reduce the risk of starting the power tool accidentally.
 - Store idle power tools out of the reach of children and do not allow persons unfamiliar with the power tool or these instructions to operate the power tool.** Power tools are dangerous in the hands of untrained users.
 - Maintain power tools. Check for misalignment or binding of moving parts, breakage of parts and any other condition that may affect the power tool's operation. If damaged, have the power tool repaired before use.** Many accidents are caused by poorly maintained power tools.
 - Keep cutting tools sharp and clean.** Properly maintained cutting tools with sharp cutting edges are less likely to bind and are easier to control.
 - Use the power tool, accessories and tool bits etc. in accordance with these instructions, taking into account the working conditions and the work to be performed.** Use of the power tool for operations different from those intended could result in a hazardous situation.
- ## 5. Service
- Have your power tool serviced by a qualified repair person using only identical replacement parts.** This will ensure that the safety of the power tool is maintained.
 - If the supply cord is damaged, it must be replaced by the manufacturer, its service agent or similarly qualified persons in order to avoid a hazard.**

CUT-OFF SAW SAFETY WARNINGS

This appliance is not intended for use by young or infirm persons unless supervised by a responsible person to ensure that they can use the appliance safely.

Young children should be supervised to ensure that they do not play with the appliance.

 **WARNING!** Keep hands away from the cutting area and cutting disc. NEVER place your hand behind the cutting disc. Do not attempt to remove cut material when cutting disc is moving. Contact with the cutting disc may cause serious personal injury.

- Keep the lower guard attached and working properly.** Ensure the guard is in the maximum cutting disc covering position over the workpiece. Do not use the cutting off grinders without guards in position.
- Keep your body positioned to either side of the cutting disc, but not in line with the cutting disc.** It is important to position your body and the guard to minimize body exposure from the possible fragments of a disintegrating cutting disc.
- Abrasive cutting discs must have a maximum safe operating speed greater than the "no load RPM" marked on the rating label.** Cutting discs running over the rated speed can disintegrate and cause injury.
- Use proper apparel while using an abrasive cut-off machine.** This includes face shield, safety goggles, dust mask and gloves.
- Before each use, inspect the cutting disc for chips and cracks.** Do not use a cutting disc that may be damaged. Fragments from a cutting disc that disintegrates during operation can cause serious injury or property damage.
- Always use the vice to clamp the work and properly support the over-hanging portion of the workpiece level with the table of the machine.** Proper support of the workpiece is important to keep the cut-off and over-hanging metal from falling and striking the operator.
- Do not force the abrasive cutting disc into the work or apply excessive pressure while using the machine.** Avoid bouncing the cutting disc or giving it rough treatment. If the cutting disc is damaged due to misuse, it may develop cracks and disintegrate without warning.
- Use only cutting discs recommended by the manufacturer.** The cutting disc should have marked speed equal to or greater than that marked on the machine. Read the operating instructions supplied by the cutting disc manufacturer.

- Do not use a metal circular saw blade or toothed blades.** These blades are not intended for this machine and could create loss of control during use or cause injury to persons and damage to property.
- Do not attempt to cut wood or plastic with this tool.** Cutting wood and plastic could cause them to burn due to friction heating.
- Do not attempt to cut masonry.** Dust generated by cutting masonry will clog the motor causing premature failure and thereby voiding the warranty.
- Do not operate this tool near flammable liquids, gasses or dust.** Sparks from the motor or cutting may ignite dust and fumes.
- Never cut magnesium with this tool.** The dust generated when cutting magnesium is highly flammable and may be explosive under certain conditions.

Regularly clean the tool's air vents with compressed air. Excessive accumulation of powered metal inside the motor housing may cause electrical failures.

Cutting capacity

The wide vice opening and high pivot point provide cutting capacity for many large pieces. Use the cutting capacity chart below to determine the maximum size of cuts that can be made with a new wheel.

CAUTION: Certain large, circular or irregularly shaped objects may require additional holding means if they cannot be held securely in the vice.

CAUTION: Do not cut magnesium with this tool.

Cutting Capacity @ 90°	
Round	130mm
Square	120mm
Rectangular	120 x 130mm
Angle iron	140mm

Note: Capacity shown on the chart assumes no cutting disc wear and optimum fence position.