



Robert Bosch GmbH
Power Tools Division
70745 Leinfelden-Echterdingen
Germany

www.bosch-pt.com

1 609 929 W25 (2010.01) PS / 23 **XXX**



1 609 929 W25

PCM 1800

 **BOSCH**

en Original instructions



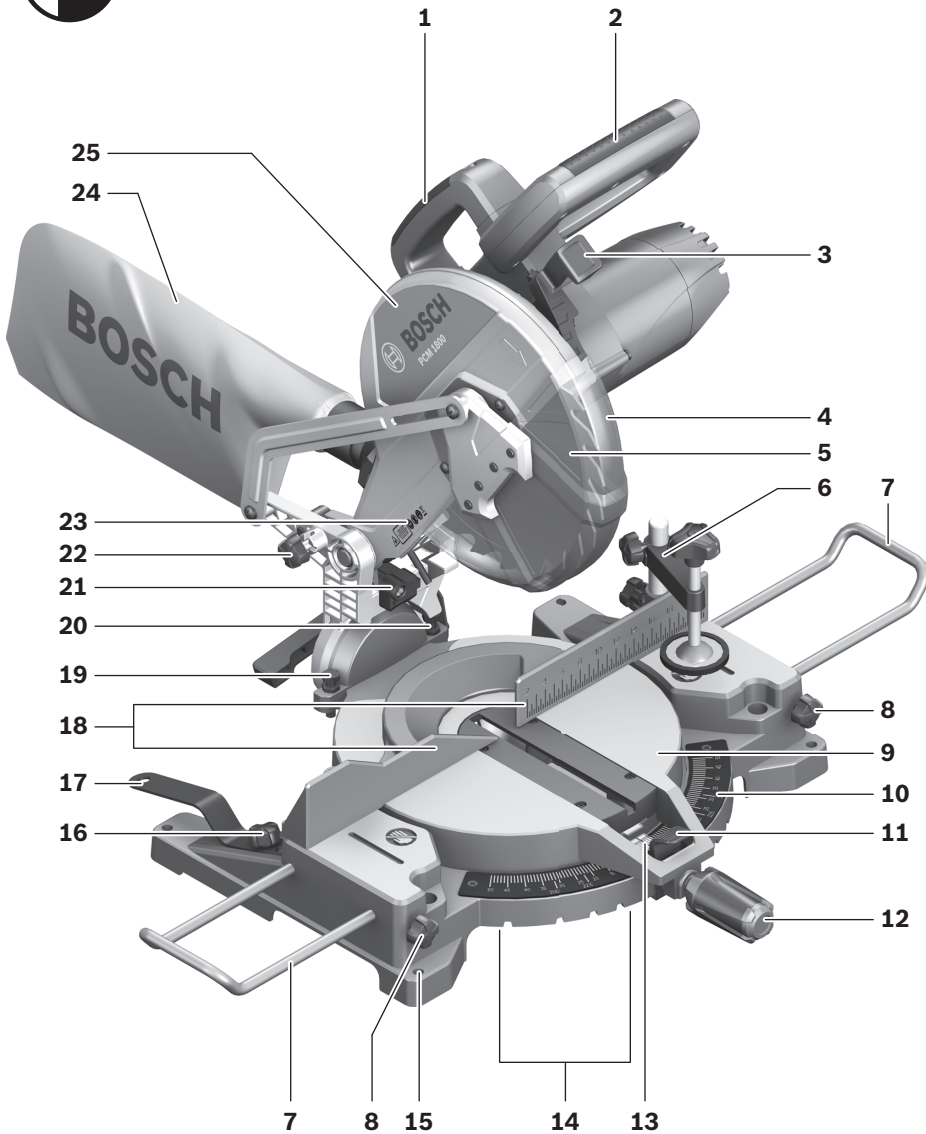

PCM 1800

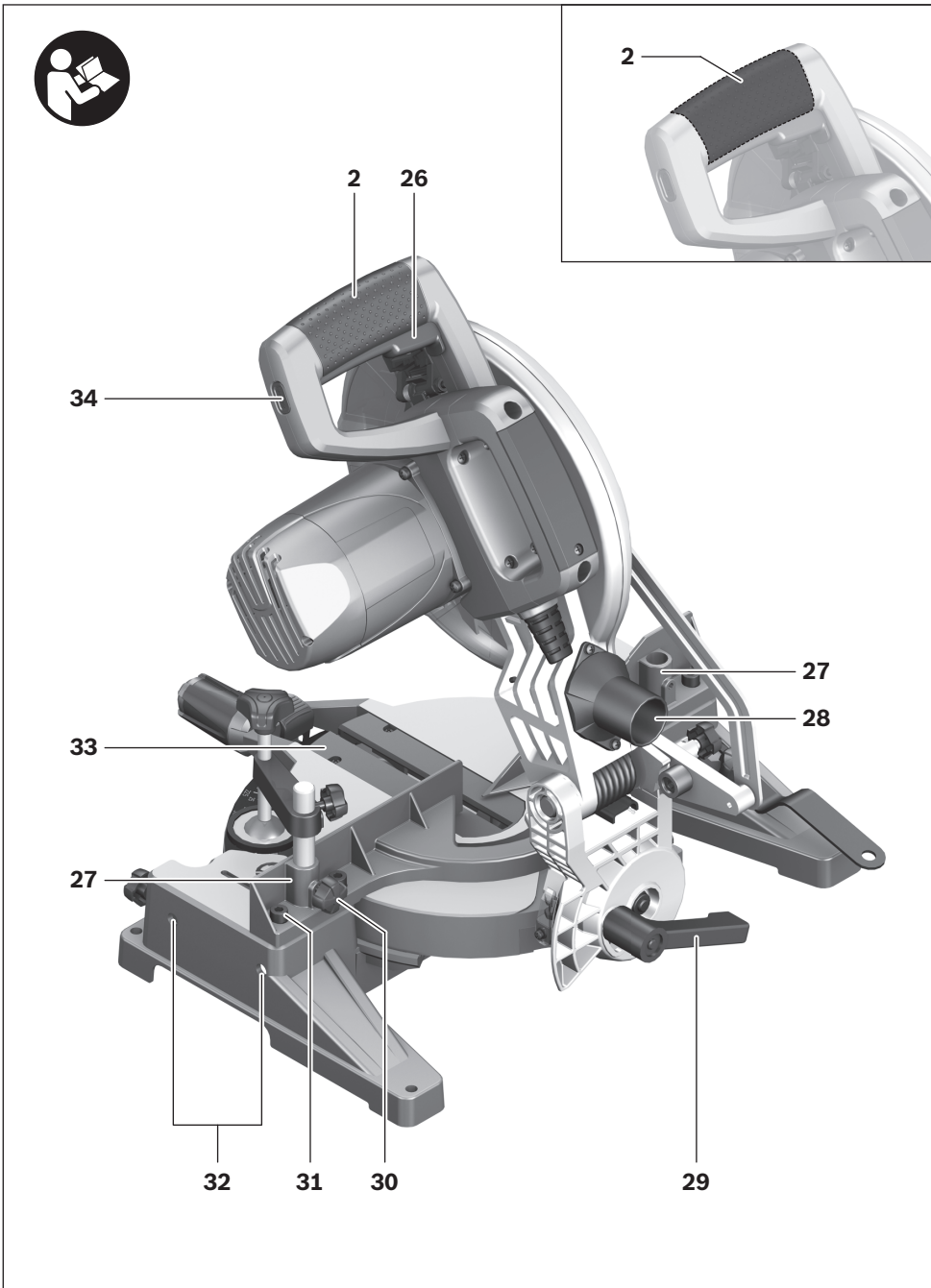

4 |

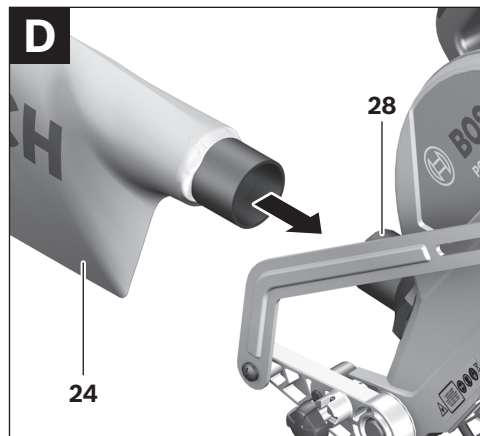
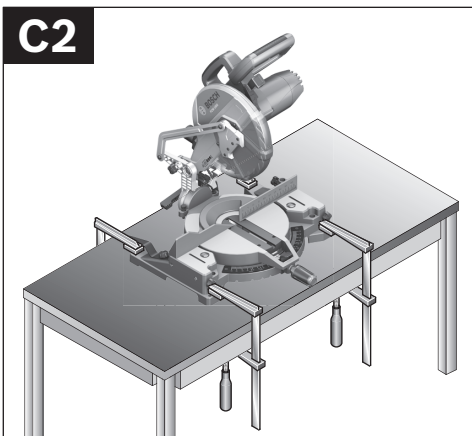
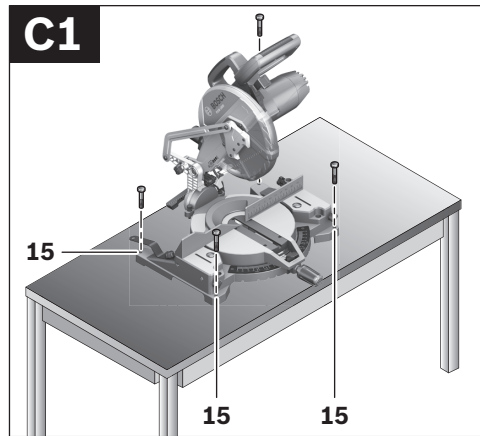
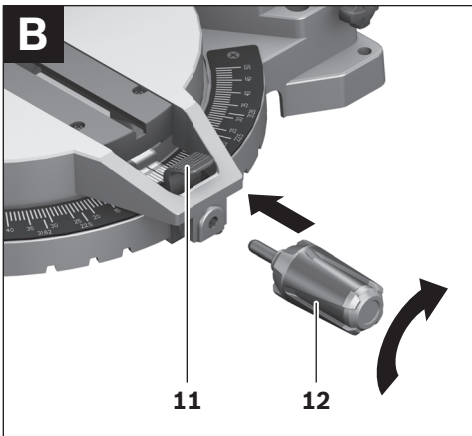
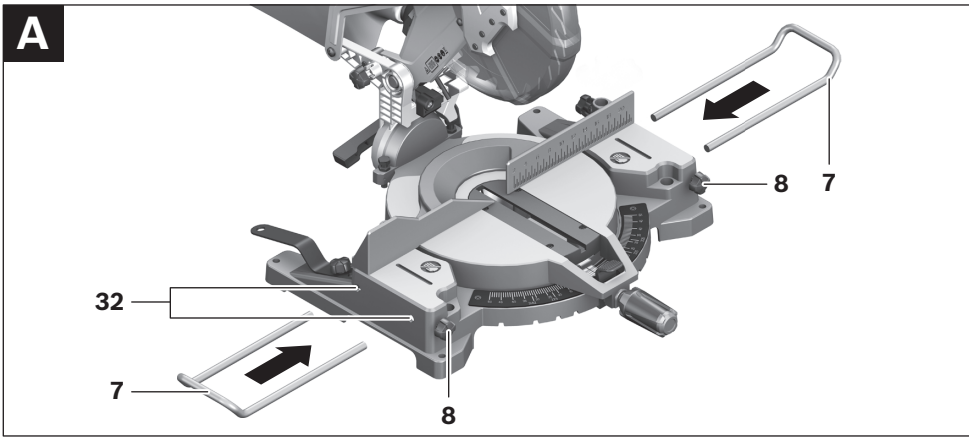

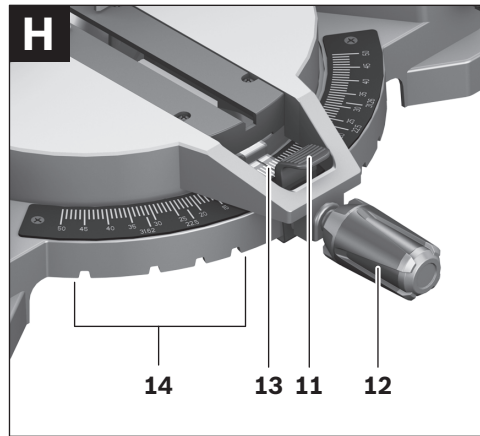
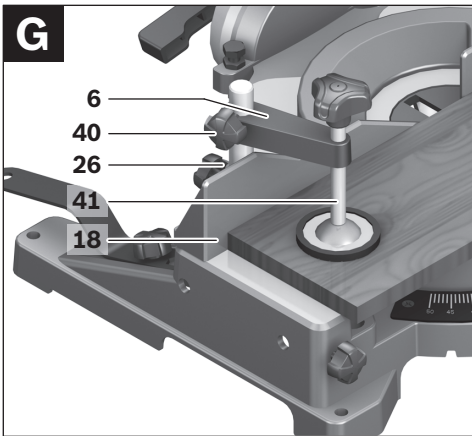
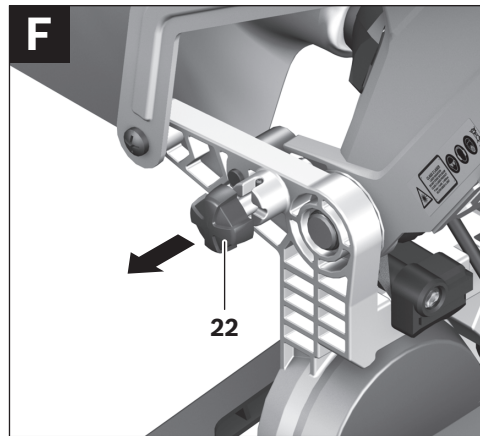
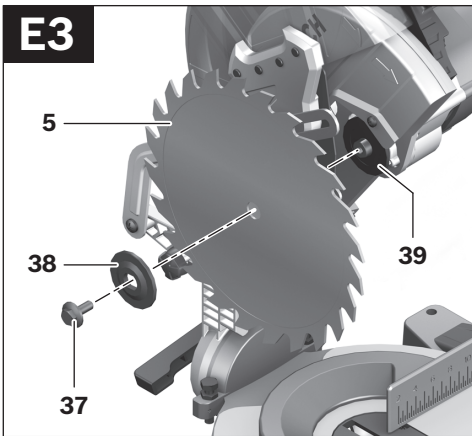
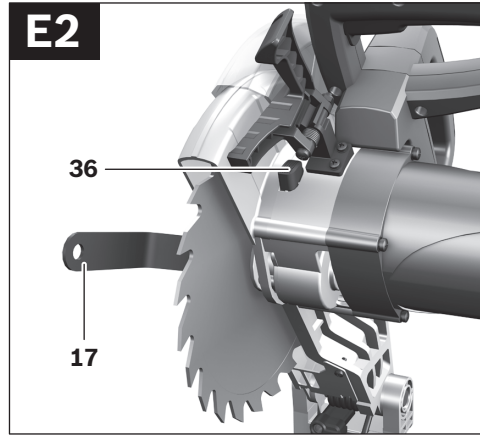
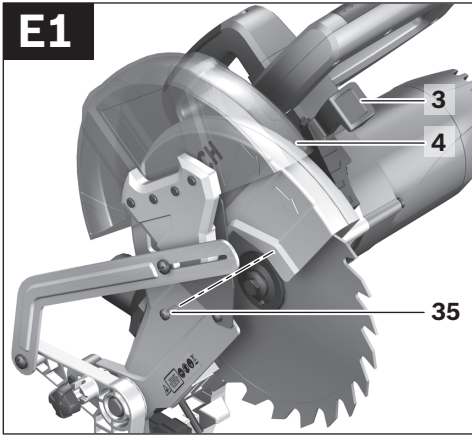

6 |

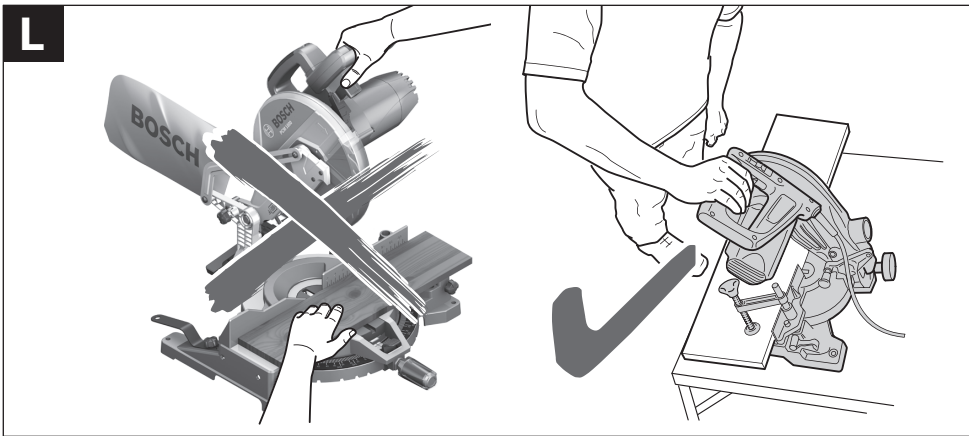
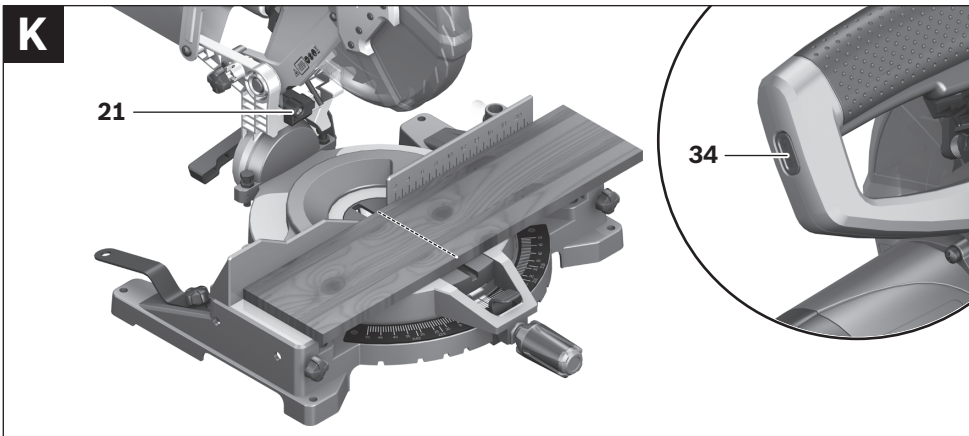
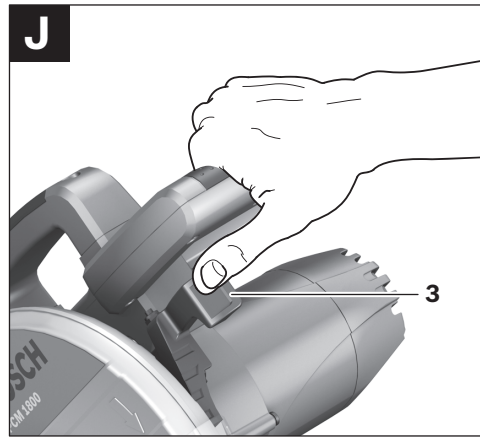
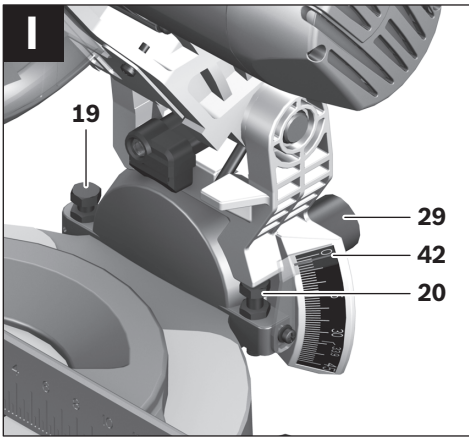

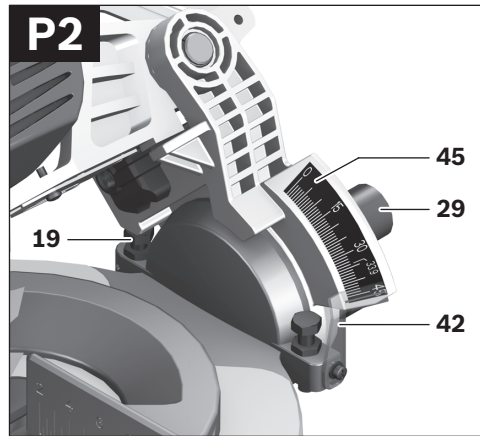
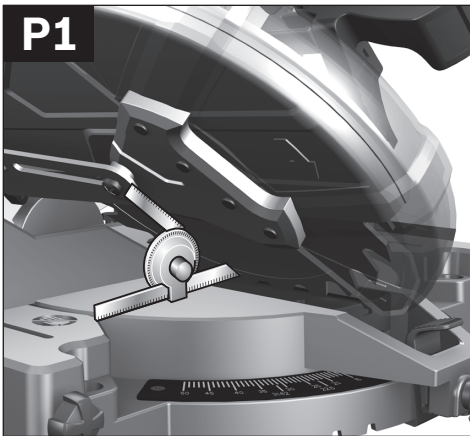
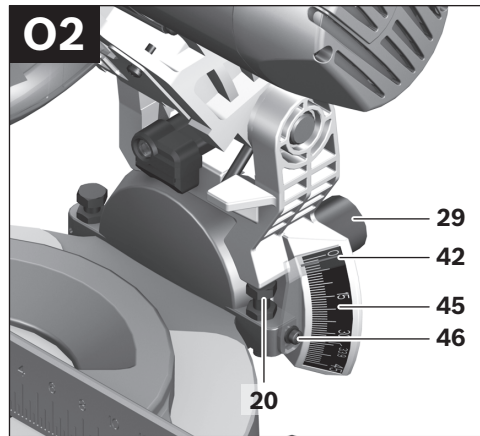
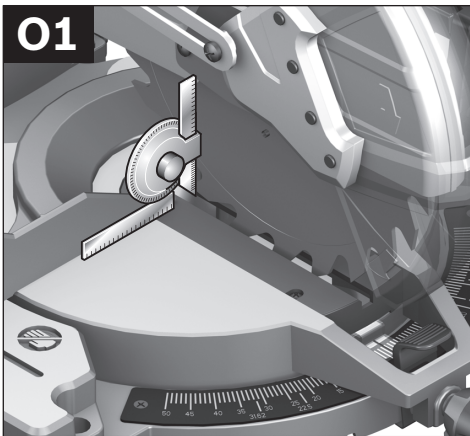
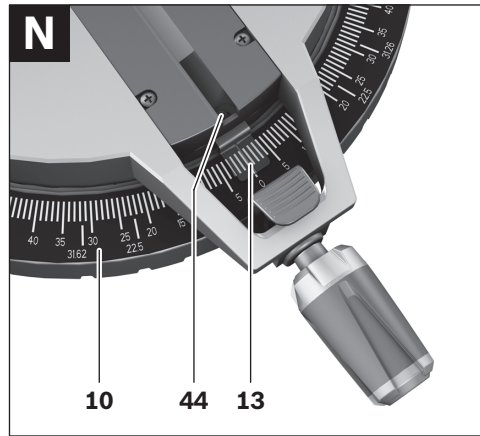
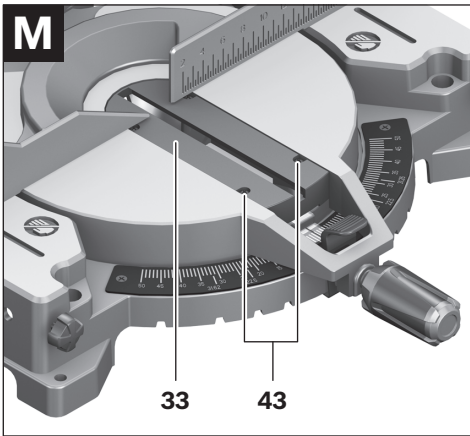

8 |

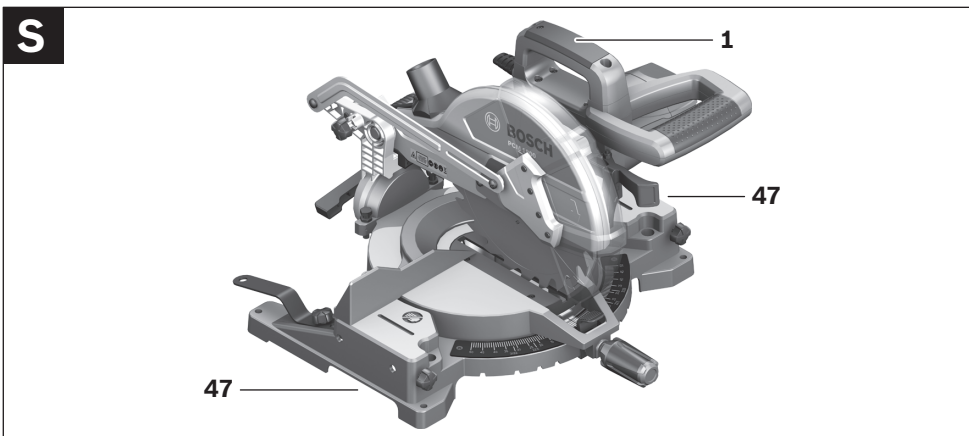
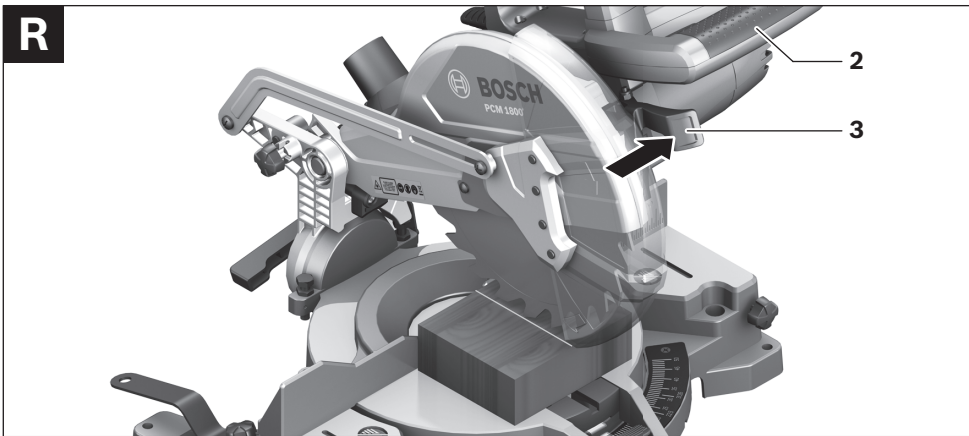
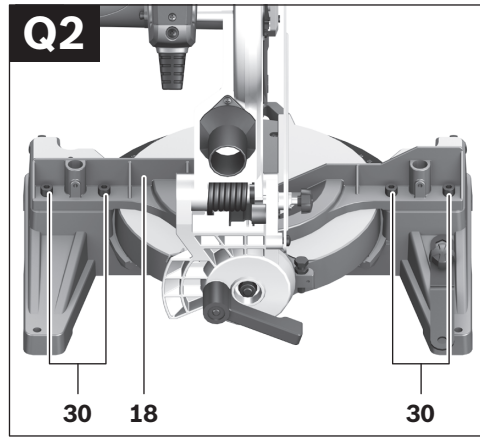
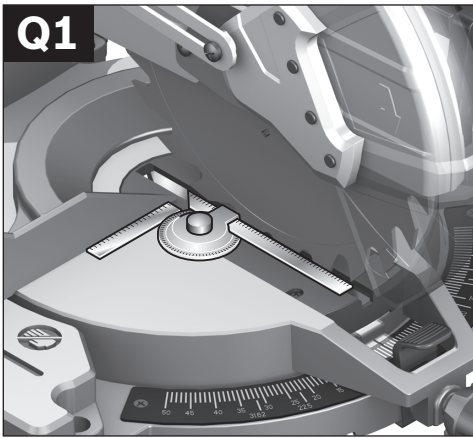

Safety Notes

General Power Tool Safety Warnings

⚠ WARNING Read all safety warnings and all instructions. Failure to follow

the warnings and instructions may result in electric shock, fire and/or serious injury.

Save all warnings and instructions for future reference.

The term “power tool” in the warnings refers to your mains-operated (corded) power tool or battery-operated (cordless) power tool.

1) Work area safety

- a) **Keep work area clean and well lit.** Cluttered or dark areas invite accidents.
- b) **Do not operate power tools in explosive atmospheres, such as in the presence of flammable liquids, gases or dust.** Power tools create sparks which may ignite the dust or fumes.
- c) **Keep children and bystanders away while operating a power tool.** Distractions can cause you to lose control.

2) Electrical safety

- a) **Power tool plugs must match the outlet. Never modify the plug in any way. Do not use any adapter plugs with earthed (grounded) power tools.** Unmodified plugs and matching outlets will reduce risk of electric shock.
- b) **Avoid body contact with earthed or grounded surfaces, such as pipes, radiators, ranges and refrigerators.** There is an increased risk of electric shock if your body is earthed or grounded.
- c) **Do not expose power tools to rain or wet conditions.** Water entering a power tool will increase the risk of electric shock.
- d) **Do not abuse the cord. Never use the cord for carrying, pulling or unplugging the power tool. Keep cord away from heat, oil, sharp edges and moving parts.** Damaged or entangled cords increase the risk of electric shock.

e) **When operating a power tool outdoors, use an extension cord suitable for outdoor use.** Use of a cord suitable for outdoor use reduces the risk of electric shock.

f) **If operating a power tool in a damp location is unavoidable, use a residual current device (RCD) protected supply.** Use of an RCD reduces the risk of electric shock.

3) Personal safety

- a) **Stay alert, watch what you are doing and use common sense when operating a power tool. Do not use a power tool while you are tired or under the influence of drugs, alcohol or medication.** A moment of inattention while operating power tools may result in serious personal injury.
- b) **Use personal protective equipment. Always wear eye protection.** Protective equipment such as dust mask, non-skid safety shoes, hard hat, or hearing protection used for appropriate conditions will reduce personal injuries.
- c) **Prevent unintentional starting. Ensure the switch is in the off-position before connecting to power source and/or battery pack, picking up or carrying the tool.** Carrying power tools with your finger on the switch or energising power tools that have the switch on invites accidents.
- d) **Remove any adjusting key or wrench before turning the power tool on.** A wrench or a key left attached to a rotating part of the power tool may result in personal injury.
- e) **Do not overreach. Keep proper footing and balance at all times.** This enables better control of the power tool in unexpected situations.
- f) **Dress properly. Do not wear loose clothing or jewellery. Keep your hair, clothing and gloves away from moving parts.** Loose clothes, jewellery or long hair can be caught in moving parts.

10 | English

g) If devices are provided for the connection of dust extraction and collection facilities, ensure these are connected and properly used. Use of dust collection can reduce dust-related hazards.

4) Power tool use and care

a) Do not force the power tool. Use the correct power tool for your application. The correct power tool will do the job better and safer at the rate for which it was designed.

b) Do not use the power tool if the switch does not turn it on and off. Any power tool that cannot be controlled with the switch is dangerous and must be repaired.

c) Disconnect the plug from the power source and/or the battery pack from the power tool before making any adjustments, changing accessories, or storing power tools. Such preventive safety measures reduce the risk of starting the power tool accidentally.

d) Store idle power tools out of the reach of children and do not allow persons unfamiliar with the power tool or these instructions to operate the power tool.

Power tools are dangerous in the hands of untrained users.

e) Maintain power tools. Check for misalignment or binding of moving parts, breakage of parts and any other condition that may affect the power tool's operation. If damaged, have the power tool repaired before use. Many accidents are caused by poorly maintained power tools.

f) Keep cutting tools sharp and clean. Properly maintained cutting tools with sharp cutting edges are less likely to bind and are easier to control.

g) Use the power tool, accessories and tool bits etc. in accordance with these instructions, taking into account the working conditions and the work to be performed. Use of the power tool for operations different from those intended could result in a hazardous situation.

5) Service

a) Have your power tool serviced by a qualified repair person using only identical replacement parts. This will ensure that the safety of the power tool is maintained.

Safety Warnings for Chop and Mitre Saws

▶ **The power tool is provided with a laser warning label (marked with number 23 in the representation of the power tool on the graphics page).**

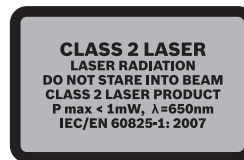

▶ **Never make warning signs on the machine unrecognisable.**

▶ **Never stand on the power tool.** Serious injuries can occur when the power tool tips over or when inadvertently coming into contact with the saw blade.

▶ **Make sure that the guard operates properly and that it can move freely.** Never lock the guard in place when opened.

▶ **Do not use the saw without guards in position.**

▶ **Keep hands away from the cutting area while the machine is running.** Danger of injury when coming in contact with the saw blade.







▶ **Never remove cutting remainders, wood chips, etc. from the sawing area while the machine is running.** Always guide the tool arm back to the neutral position first and then switch the machine off.

▶ **Guide the saw blade against the workpiece only when the machine is switched on.** Otherwise there is damage of kickback, when the saw blade becomes wedged in the workpiece.

- ▶ **Keep handles dry, clean, and free from oil and grease.** Greasy, oily handles are slippery causing loss of control.
 - ▶ **Operate the power tool only when the work area to the workpiece is clear of any adjusting tools, wood chips, etc.** Small pieces of wood or other objects that come in contact with the rotating saw blade can strike the operator with high speed.
 - ▶ **Always firmly clamp the piece to be worked. Do not saw workpieces that are too small to clamp.** Otherwise, the clearance of your hand to the rotating saw blade is too small.
 - ▶ **Use the machine only for cutting the materials listed under Intended Use.** Otherwise, the machine can be subject to overload.
 - ▶ **If the saw blade should become jammed, switch the machine off and hold the workpiece until the saw blade comes to a complete stop. To prevent kickback, the workpiece may not be moved until after the machine has come to a complete stop.** Correct the cause for the jamming of the saw blade before restarting the machine.
 - ▶ **Do not use dull, cracked, bent or damaged saw blades.** Unsharpened or improperly set saw blades produce narrow kerf causing excessive friction, blade binding and kickback.
 - ▶ **Always use saw blades with correct size and shape (diamond versus round) of arbor holes.** Saw blades that do not match the mounting hardware of the saw will run eccentrically, causing loss of control.
 - ▶ **Do not use high speed steel (HSS) saw blades.** Such saw blades can easily break.
 - ▶ **Do not touch the saw blade after working before it has cooled.** The saw blade becomes very hot while working.
 - ▶ **Never operate the machine without the insert plate. Replace a defective insert plate.** Without flawless insert plates, injuries are possible from the saw blade.
 - ▶ **Check the cable regularly and have a damaged cable repaired only through an authorised customer service agent for Bosch power tools. Replace damaged extension cables.** This will ensure that the safety of the power tool is maintained.
 - ▶ **Store the machine in a safe manner when not being used. The storage location must be dry and lockable.** This prevents the machine from storage damage, and from being operated by untrained persons.
 - ▶ **Do not direct the laser beam at persons or animals and do not stare into the laser beam yourself, not even from a distance.**
This power tool produces laser class 2 laser radiation according to IEC/EN 60825-1. This can lead to persons being blinded.
 - ▶ **Do not allow children unsupervised use of the power tool with laser.** They could blind other people.
 - ▶ **Do not replace the installed laser with another laser type.** A laser that does not fit to this power tool could pose dangers for other persons.
 - ▶ **Secure the workpiece.** A workpiece clamped with clamping devices or in a vice is held more secure than by hand.
 - ▶ **Keep your workplace clean.** Blends of materials are particularly dangerous. Dust from light alloys can burn or explode.
 - ▶ **Never leave the machine before it has come to a complete stop.** Cutting tools that are still running can cause injuries.
 - ▶ **Never use the machine with a damaged cable. Do not touch the damaged cable and pull the mains plug when the cable is damaged while working.** Damaged cables increase the risk of an electric shock.
- Products sold in AUS and NZ only:** Use a residual current device (RCD) with a rated residual current of 30 mA or less.

Symbols

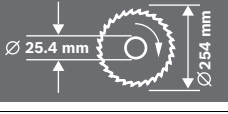
The following symbols can be important for the operation of your power tool. Please memorise the symbols and their meanings. The correct interpretation of the symbols helps you operate the power tool better and more secure.

Symbol	Meaning
	▶ Wear a dust respirator.
	▶ Wear safety goggles.
	▶ Wear ear protectors. Exposure to noise can cause hearing loss.
	▶ Do not direct the laser beam at persons or animals and do not stare into the laser beam yourself, not even from a distance. This power tool produces laser class 2 laser radiation according to IEC/EN 60825-1. This can lead to persons being blinded.
	Observe the dimensions of the saw blade. The hole diameter must match the tool spindle without play. Do not use reducers or adapters.
	▶ Danger area! Keep hands, fingers or arms away from this area.

Functional Description



Read all safety warnings and all instructions. Failure to follow the warnings and instructions may result in electric shock, fire and/or serious injury.

Intended Use

The power tool is intended as a stationary machine for making straight lengthways and crossways cuts in wood. Horizontal mitre angles of -45° to $+45^\circ$ as well as vertical bevel angles of 0° to 45° are possible.

The machine is designed with sufficient capacity for sawing hard and softwood as well as press and particle board.

The power tool is not suitable for cutting aluminium or other non-ferrous metals or alloys.

Product Features

The numbering of the components shown refers to the representation of the power tool on the graphic pages.

- 1 Transport handle
- 2 Handle
- 3 Locking lever
- 4 Retracting blade guard
- 5 Saw blade
- 6 Material clamp
- 7 Extension bar
- 8 Fastening screw for extension bar
- 9 Saw table
- 10 Scale for mitre angle (horizontal)
- 11 Lever for mitre angle adjustment (horizontal)
- 12 Locking knob for various mitre angles (horizontal)
- 13 Angle indicator (horizontal)
- 14 Detents for standard mitre angles
- 15 Mounting holes
- 16 Fastening screw for ring spanner
- 17 Ring spanner (13 mm)
- 18 Fence
- 19 Stop screw for 45° bevel angle (vertical)
- 20 Stop screw for 0° bevel angle (vertical)
- 21 Laser unit
- 22 Transport safety-lock
- 23 Laser warning label
- 24 Dust bag
- 25 Blade guard
- 26 On/Off switch
- 27 Drill holes for material clamp
- 28 Sawdust ejector
- 29 Clamping lever for various bevel angles (vertical)
- 30 Fastening screw for screw clamp
- 31 Allen screws (6 mm) of the fence
- 32 Drill holes for extension bars
- 33 Insert plate
- 34 Laser switch (for marking of cutting line)
- 35 Phillips screw (attachment of retracting blade guard)
- 36 Spindle lock
- 37 Hexagon bolt for saw-blade attachment
- 38 Clamping flange
- 39 Interior clamping flange
- 40 Locking screw of the screw clamp
- 41 Threaded rod
- 42 Angle indicator (vertical)
- 43 Screws for insert plate
- 44 Screw for angle indicator (horizontal)
- 45 Scale for bevel angle (vertical)
- 46 Screw for angle indicator (vertical)
- 47 Recessed grips

Accessories shown or described are not part of the standard delivery scope of the product. A complete overview of accessories can be found in our accessories program.

14 | English

Technical Data

Chop and Mitre Saw		PCM 1800
Article number		3 603 L01 040
Rated power input	W	1800
Rated voltage	V	240
Frequency	Hz	50
No-load speed	min ⁻¹	4500
Cutting capacity, max.	mm	70
Laser type		650 nm, < 1 mW
Laser class		2
Weight according to EPTA-Procedure 01/2003	kg	13.8
Protection class		□/II

Permissible workpiece dimensions (maximal/minimal) see page 18.

The values given are valid for nominal voltages [U] of 230/240 V. For lower voltage and models for specific countries, these values can vary.

Please observe the article number on the type plate of your machine. The trade names of the individual machines may vary.

Dimension of suitable saw blades

Saw blade diameter	mm	254
Blade thickness	mm	1.5–2.8
Mounting hole diameter	mm	25.4

Assembly

- **Avoid unintentional starting of the machine. During assembly and for all work on the machine, the power plug must not be connected to the mains supply.**

Delivery Scope

Before starting the operation of the machine for the first time, check if all parts listed below have been supplied:

- Chop and mitre saw with mounted saw blade
- Dust bag **24**
- Locking knob **12**
- Extension bar **7** (2x)
- Material clamp **6**
- Ring spanner **17**

Note: Check the power tool for possible damage.

Before further use of the machine, check that all protective devices are fully functional. Any lightly damaged parts must be carefully checked to ensure flawless operation of the tool. All parts must be properly mounted and all conditions fulfilled that ensure faultless operation.

Damaged protective devices and parts must be immediately replaced by an authorised service centre.

Additionally required tools (not in delivery scope):

- Phillips screwdriver
- Angle gauge
- Open-end spanner (13 mm)
- Allen key (6 mm)

Mounting Individual Components

- Carefully remove all parts included in the delivery from their packaging.
- Remove all packaging material from the machine and the accessories provided.

Mounting the Extension Bars (see figure A)

To extend the saw table additionally, extension bars can be mounted both to the left or right of the power tool.

- Insert the extension bars **7** on both sides of the power tool to the stop in the drill holes **32** intended for this purpose.
- Firmly tighten fastening screws **8**.

Mounting the Locking Knob (see figure B)

- Screw the locking knob **12** into the corresponding threaded hole below lever **11**.
- ▶ **Always tighten the locking knob 12 firmly before sawing.** Otherwise the saw blade can become wedged in the workpiece.

Stationary or Flexible Mounting (see figures C1–C2)

- ▶ **To ensure safe handling, the machine must be mounted on a level and stable surface (e. g., workbench) prior to using.**
 - Fasten the power tool with suitable screw fasteners to the working surface. The holes **15** serve for this purpose.
- or
- Clamp the power tool with commercially available screw clamps by the feet to the working surface.

Dust/Chip Extraction

Dusts from materials such as lead-containing coatings, some wood types, minerals and metal can be harmful to one's health. Touching or breathing-in the dusts can cause allergic reactions and/or lead to respiratory infections of the user or bystanders.

Certain dusts, such as oak or beech dust, are considered as carcinogenic, especially in connection with wood-treatment additives (chromate, wood preservative). Materials containing asbestos may only be worked by specialists.

- Use dust extraction whenever possible.
- Provide for good ventilation of the working place.
- It is recommended to wear a P2 filter-class respirator.

Observe the relevant regulations in your country for the materials to be worked.

The dust/chip extraction can be blocked by dust, chips or workpiece fragments.

- Switch the machine off and pull the mains plug from the socket outlet.
- Wait until the saw blade has come to a complete stop.
- Determine the cause of the blockage and correct it.

Integrated Dust Extraction (see figure D)

- Mount the dust bag **24** onto the sawdust ejector **28**.

During sawing, the dust bag must never come into contact with the movable machine parts.

Always empty the dust bag in good time.

External Dust Extraction

For dust extraction, a vacuum hose (size Ø 35 mm) can also be connected to the dust ejector.

The vacuum cleaner must be suitable for the material being worked.

When vacuuming dry dust that is especially detrimental to health or carcinogenic, use a special vacuum cleaner.

Changing the Tool (see figures E1–E3)

- ▶ **Before any work on the machine itself, pull the mains plug.**
- ▶ **When mounting the saw blade, wear protective gloves.** Danger of injury when touching the saw blade.

Use only saw blades whose maximum permitted speed is higher than the no-load speed of the power tool.

Use only saw blades that correspond with the characteristic data given in these operation instructions and that are tested and marked in accordance with EN 847-1.

Use only saw blades recommended by the tool manufacturer, and suitable for sawing the materials to be cut.

Removing the Saw Blade

- Bring the power tool into the working position.
- Completely unscrew screw **35**.
Do not lose the snap ring while removing the screw from the blade guard.
- Push the locking lever **3** and swing the retracting blade guard **4** to the rear to the stop.
- Turn hexagon bolt **37** with the provided ring spanner **17** and at the same time press the spindle lock **36** until it engages.
- Keep the spindle lock **36** pressed and unscrew hexagon bolt **37** in clockwise direction (**left-hand thread!**).
- Remove the clamping flange **38**.
- Remove the saw blade **5**.

Mounting the Saw Blade

If required, clean all parts to be mounted prior to assembly.

- Place the new saw blade onto the interior clamping flange **39**.
- ▶ **When mounting the saw blade, pay attention that the cutting direction of the teeth (arrow direction on the saw blade) corresponds with the direction of the arrow on the blade guard!**

- Mount the clamping flange **38** and hexagon bolt **37**.
Press the spindle lock **36** until it engages and tighten the hexagon bolt in anticlockwise direction.
- Push the locking lever **3** and guide the retracting blade guard **4** down again.
- Screw in screw **35** together with the snap ring and retighten again.

Operation

- ▶ **Before any work on the machine itself, pull the mains plug.**

Transport Safety (see figure F)

The transport safety-lock **22** enables easier handling of the machine when transporting to various working locations.

Releasing the Machine (Working Position)

- Push the tool arm by the handle **2** down a little in order to relieve the transport safety-lock **22**.
- Pull the transport safety-lock **22** completely outward.
- Guide the tool arm slowly upward.

Securing the Machine (Transport Position)

- Push the locking lever **3** and at the same time move the tool arm by the handle **2** downward.
- Guide the tool arm downward until the transport safety-lock **22** can be pushed completely inward.

The tool arm is now securely locked for transport.

Clamping the Workpiece (see figure G)

To ensure optimum working safety, the workpiece must always be firmly clamped. Do not saw workpieces that are too small to clamp.

- Press the workpiece firmly against the fence **18**.
- Insert the material clamp **6** provided into one of the holes **27** intended for it.
- Tighten fastening screw **30**.
- Loosen locking screw **40** and adjust the screw clamp to the workpiece. Retighten the locking screw again.
- Firmly clamp the workpiece by turning the threaded rod **41** in clockwise direction.

Loosening the Workpiece

- To release the material clamp, turn the threaded rod **41** in anticlockwise direction.

Adjusting the Cutting Angle

To ensure precise cuts, the basic adjustment of the machine must be checked and adjusted as necessary after intensive use (see “Checking and Adjusting the Basic Adjustment”, page 19).

- ▶ **Always tighten the locking knob 12 firmly before sawing.** Otherwise the saw blade can become wedged in the workpiece.

Adjusting Horizontal Standard Mitre Angles (see figure H)

For quick and precise adjustment of commonly used mitre angles, detents **14** have been provided for on the saw table:

Left	Right
0°	
15°; 22.5°; 31.6°; 45°	15°; 22.5°; 31.6°; 45°

- Loosen the locking knob **12** in case it is tightened.
- Press lever **11** and turn the saw table **9** left or right to the requested detent.
- Release the lever again. The lever must be felt to engage in the detent.

Adjusting Any Horizontal Mitre Angle

The horizontal mitre angle can be set in the range from 45° (left side) to 45° (right side).

- Loosen the locking knob **12** in case it is tightened.
- Press lever **11**, turn saw table **9** via the locking knob left or right and adjust the desired mitre angle with help of the angle indicator **13**.
- Tighten the locking knob **12** again.

Adjusting Vertical Bevel Angles (see figure I)

The vertical bevel angle can be set in the range from 0° to 45°.

- Loosen the clamping lever **29**.
- Tilt the tool arm by the handle **2** until the angle indicator **42** indicates the desired bevel angle.
- Hold the tool arm in this position and retighten the clamping lever **29**.

For quick and precise setting of the standard angles 0° and 45°, factory-set stop screws (**20** and **19**) have been provided for.

- For this, tilt the tool arm by the handle **2** to the stop toward the right (0°) or to the stop toward the left (45°).
- Retighten the clamping lever **29** again.

Starting Operation

Switching On (see figure J)

- To **start** the machine, press the On/Off switch **26** and keep it pressed.

Note: For safety reasons, the On/Off switch **26** cannot be locked; it must remain pressed during the entire operation.

The tool arm can be guided down only after pushing the locking lever **3**.

- For **sawing**, you must additionally press lever **3** in addition to actuating the On/Off switch.

Switching Off

- To **switch off** the machine, release the On/Off switch **26**.

Working Advice

General Sawing Instructions

- ▶ **For all cuts, it must first be ensured that the saw blade at no time can come in contact with the fence, screw clamps or other machine parts. Remove possibly mounted auxiliary stops or adjust them accordingly.**
- ▶ **Wenn slotting, ensure that the saw blade doesn't get jammed in the workpiece.**

Protect the saw blade against impact and shock. Do not subject the saw blade to lateral pressure. Do not saw warped/bent workpieces. The workpiece must always have a straight edge to face against the fence.

Marking the Cutting Line (see figure K)

A laser beam indicates the cutting line of the saw blade. This allows for exact positioning of the workpiece for sawing, without having to open the retracting blade guard.

- For this, switch the laser beam on with the switch **34**.
- Align the cutting mark on your workpiece with reference to the right-hand edge of the laser line.

Position of the Operator (see figure L)

- ▶ **Do not stand in a line with the saw blade in front of the machine. Always stand aside of the saw blade.** This protects your body against possible kickback.
- Keep hands, fingers and arms away from the rotating saw blade.
- Do not cross your arms when operating the tool arm.

Permissible Workpiece Dimensions

Maximal workpiece sizes:

Mitre/Bevel Angle		Height x Width [mm]
Horizontal	Vertical	
0°	0°	70 x 130
45°	0°	70 x 90
0°	45°	38 x 130
45°	45°	38 x 90

Minimal workpiece sizes

(= all workpieces that can be clamped left or right from the saw blade with the supplied material clamp **6**):

130 x 35 mm x 5 mm

(length x width x thickness)

Cutting capacity, max. (0°/0°): 70 mm

Cutting Off

- Firmly clamp the workpiece as appropriate for its dimensions.
- Adjust the requested horizontal and/or vertical mitre/bevel angle.
- Switch on the machine.
- Push the locking lever **3** and guide the tool arm slowly downward with the tool handle **2**.
- Saw through the workpiece applying uniform feed.
- Switch off the machine and wait until the saw blade has come to a complete stop.
- Guide the tool arm slowly upward.

Special Workpieces

When sawing curved or round workpieces, these must be especially secured against slipping. At the cutting line, no gap may exist between workpiece, fence and saw table.

Provide for special fixtures, if required.

Replacing the Insert Plate (see figure M)

The red insert plate **33** can become worn after long use of the power tool.

Replace defective insert plates.

- Bring the power tool into the working position.
- Unscrew screws **43** using a Phillips screwdriver and remove the old insert plate.
- Insert the new insert plate and screw all screws **43** in again.

Sawing Profile Strips

Profile strips/mouldings can be sawn in two different ways:

- Placed against the fence

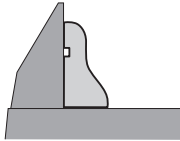

- Lying flat on the saw table

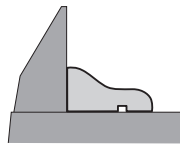

Always make trial cuts with the mitre angle setting first on scrap wood.

Checking and Adjusting the Basic Adjustment

- ▶ **Before any work on the machine itself, pull the mains plug.**

To ensure precise cuts, the basic adjustment of the machine must be checked and adjusted as necessary after intensive use.

A certain level of experience and appropriate specialty tools are required for this.

A Bosch after-sales service station will handle this maintenance task quickly and reliably.

Aligning the Angle Indicator (Horizontally) (see figure N)

- Bring the power tool into the working position.
- Turn the saw table **9** to the 0° detent **14**. The lever **11** must be felt to engage in the detent.

Checking:

The centre line of the angle indicator **13** must be in line with the 0° mark of the scale **10**.

Adjusting:

- Remove the insert plate **33**.
- Loosen the screw **44** using a commercial Phillips screwdriver and align the centre line of the angle indicator alongside the 0° mark.
- Retighten the screw again.

Setting the Standard Bevel Angle 0° (Vertical)

- Bring the machine into the transport position.
- Turn the saw table **9** to the 0° detent **14**. The lever **11** must be felt to engage in the detent.

Checking: (see figure O1)

- Set an angle gauge to 90° and place it on the saw table **9**.

The leg of the angle gauge must be flush with the saw blade **5** over the complete length.

Adjusting: (see figure O2)

- Loosen the clamping lever **29**.
- Loosen the lock nut of stop screw **20** with a ring spanner (13 mm).
- Screw the stop screw in or out until the leg of the angle gauge is flush with the saw blade over the complete length.
- Retighten the clamping lever **29** again.
- Afterwards, retighten the lock nut of the stop screw **20** again.

In case the angle indicator **42** is not in a line with the 0° mark of the scale **45** after the adjustment, loosen the screw **46** using a commercial Phillips screwdriver and align the angle indicator along the 0° mark.

20 | English

Setting the Standard Bevel Angle 45° (Vertical)

- Bring the machine into the transport position.
- Turn the saw table **9** to the 0° detent **14**. The lever **11** must be felt to engage in the detent.
- Loosen the clamping lever **29** and tilt the tool arm leftward to the stop (45°) by the handle **2**.

Checking: (see figure P1)

- Set an angle gauge to 45° and place it on the saw table **9**.

The leg of the angle gauge must be flush with the saw blade **5** over the complete length.

Adjusting: (see figure P2)

- Loosen the lock nut of stop screw **19** with a ring spanner (13 mm).
- Screw the stop screw in or out until the leg of the angle gauge is flush with the saw blade over the complete length.
- Retighten the clamping lever **29** again.
- Afterwards, retighten the lock nut of the stop screw **19** again.

In case the angle indicator **42** is not in a line with the 45° mark of the scale **45**, firstly check the 0° setting for the bevel angle and the angle indicator again. Then repeat the adjustment of the 45° bevel angle.

Aligning the Fence

- Bring the machine into the transport position.
- Turn the saw table **9** until it engages at 0°.

Checking: (see figure Q1)

- Set an angle gauge to 90° and place it on the saw table **9** between the fence **18** and the saw blade **5**.

The leg of the angle gauge must be flush with the fence over the complete length.

Adjusting: (see figure Q2)

- Loosen all Allen screws **31** with an Allen key (6 mm).
- Turn the fence **18** until the angle gauge is flush over the complete length.
- Retighten the screws again.

Checking the Laser Beam Position (see figure R)

- Draw a straight cutting line on the workpiece.
- Push the locking lever **3** and guide the tool arm slowly downward with the tool handle **2**.
- Align the workpiece in such a manner that the teeth of the saw blade are in alignment with the cutting line.
- Hold the workpiece in this position and slowly guide the tool arm upward again.
- Clamp the workpiece.
- Switch the laser beam on with switch **34**.

The laser beam must be in alignment with the cutting line on the workpiece over the complete length, also when the tool arm is lowered.

Transport (see figure S)

Before transporting the power tool, the following steps must be carried out:

- Bring the machine into the transport position.
- Lock extension bar **7**, ring spanner **17** and screw clamp **6** with the corresponding fastening screws **8**, **16** and **30**.
- Remove all accessories that cannot be mounted firmly to the power tool.
If possible, place unused saw blades in an enclosed container for transport.
- Carry the machine by the transport handle **1** or hold it by the recessed grips **47** on the sides of the saw table.

- ▶ **The power tool should always be carried by two persons in order to avoid back injuries.**
- ▶ **When transporting the power tool, use only the transport devices and never use the protective devices.**

Maintenance and Service

Maintenance and Cleaning

- **Before any work on the machine itself, pull the mains plug.**

If the machine should fail despite the care taken in manufacturing and testing procedures, repair should be carried out by an after-sales service centre for Bosch power tools.

In all correspondence and spare parts order, please always include the 10-digit article number given on the type plate of the machine.

Cleaning

For safe and proper working, always keep the power tool and its ventilation slots clean.

The retracting blade guard must always be able to move freely and retract automatically. Therefore, always keep the area around the retracting blade guard clean.

Remove dust and chips after each working procedure by blowing out with compressed air or with a brush.

Clean the laser unit regularly **21**.

Disposal

The machine, accessories and packaging should be sorted for environmental-friendly recycling.

The plastic components are labelled for categorized recycling.

After-sales Service and Customer Assistance

Our after-sales service responds to your questions concerning maintenance and repair of your product as well as spare parts. Exploded views and information on spare parts can also be found under:

www.bosch-pt.com

Our customer service representatives can answer your questions concerning possible applications and adjustment of products and accessories.

Australia, New Zealand and Pacific Islands

Robert Bosch Australia Pty. Ltd.

Power Tools

Locked Bag 66

Clayton South VIC 3169

Customer Contact Center

Inside Australia:

Phone: +61 (01300) 307 044

Fax: +61 (01300) 307 045

Inside New Zealand:

Phone: +64 (0800) 543 353

Fax: +64 (0800) 428 570

Outside AU and NZ:

Phone: +61 (03) 9541 5555

www.bosch.com.au

Subject to change without notice.



optiline
WOOD



speedline
WOOD

fast
CUT



CONSTRUCT
WOOD

fast
CUT

