

WARNING! The appliance is not to be used by persons (including children) with reduced physical, sensory or mental capabilities, or lack of experience and knowledge, unless they have been given supervision or instruction. Young children should be supervised to ensure that they do not play with the appliance.

WARNING! High pressure injection injuries are considered to be medical emergencies. In the event of a high pressure injection injury occurring, seek medical advice immediately.

WARNING! It is prohibited to use Pressure Washers on materials containing asbestos (Cement sheet roofs, fences, walls etc.). Large numbers of asbestos fibres may be released into the air, posing a serious health hazard. If unsure about the materials you are spraying, it is recommended that you contact your local council or government authority.

• Before connecting a tool to a power source (mains switch power point receptacle, outlet, etc.) be sure that the voltage supply is the same as that specified on the nameplate of the tool. A power source with a voltage greater than that specified for the tool can result in serious injury to the user, as well as damage to the tool. If in doubt, do not plug in the tool. Using a power source with a voltage less than the nameplate rating is harmful to the motor.

• Unsafe operation of your high pressure cleaner could lead to serious injury or death to you or others. The spray gun/wand is a powerful cleaning tool that could look like a toy to a child.

• Improper control of gun/wand can result in injuries to self, others and property damage. Reactive force from the spray can result in gun/wand movement, potentially causing the operator to slip, fall or misdirect the spray.

• Become familiar with the operation and controls of the pressure cleaner.

• Keep children away from the pressure cleaner at all times.

• Never modify or remove the safety features of this product.

• Do not operate the machine with missing, broken or unauthorized parts.

• Never leave wand unattended while unit is running.

• Keep work area free of obstacles.

• Stand on stable surface and grip gun/wand firmly. Expect the gun to kick back when engaged.

• Do not use to pump flammable or explosive liquids such as gasoline, fuel oil, kerosene, solvents or thinners. Pump should only be used with liquids compatible with pressure washer component materials.

• Failure to follow to this warning can result in serious personal injury, death and/or property damage.

HIGH PRESSURE WASHER SAFETY

WARNING! When using mains-powered tools, basic safety precautions, including the following, should always be followed to reduce risk of fire, electric shock, personal injury and material damage.

Read the whole manual carefully and make sure you know how to switch the tool off in an emergency, before operating the tool.

Save these instructions and other documents supplied with this tool for future reference.

The electrical motor has been designed for 230V and 240V only. Always check that the power supply corresponds to the voltage on the rating plate.

Note: The supply of 230V and 240V on Gerni tools are interchangeable for Australia and New Zealand.



This tool is double insulated; therefore no earth wire is required.

Note: Double insulation does not take the place of normal safety precautions when operating this tool. The insulation system is for added protection against injury resulting from a possible electrical insulation failure within the tool.

ELECTRICAL SAFETY

WARNING! Read all safety warnings and all instructions. Failure to follow the warnings and instructions may result in electric shock, fire and/or serious injury.

Save all warnings and instructions for future reference. The term "power tool" in the warnings refers to your mains-operated (corded) power tool or battery-operated (cordless) power tool.

1. Work area safety

a. **Keep work area clean and well lit.** Cluttered or dark areas invite accidents.

b. **Do not operate power tools in explosive atmospheres, such as in the presence of flammable liquids, gases or dust.** Power tools create sparks which may ignite the dust or fumes.

c. **Keep children and bystanders away while operating a power tool.** Distractions can cause you to lose control.

2. Electrical safety

a. **Power tool plugs must match the outlet. Never modify the plug in any way. Do not use any adapter plugs with earthed (grounded) power tools.** Unmodified plugs and matching outlets will reduce risk of electric shock.

b. **Avoid body contact with earthed or grounded surfaces, such as pipes, radiators, ranges and refrigerators.** There is an increased risk of electric shock if your body is earthed or grounded.

c. **Do not expose power tools to rain or wet conditions.** Water entering a power tool will increase the risk of electric shock.

d. **Do not abuse the cord. Never use the cord for carrying, pulling or unplugging the power tool. Keep cord away from heat, oil, sharp edges or moving parts.** Damaged or entangled cords increase the risk of electric shock.

e. **When operating a power tool outdoors, use an extension cord suitable for outdoor use.** Use of a cord suitable for outdoor use reduces the risk of electric shock.

3. Personal safety

a. **Stay alert, watch what you are doing and use common sense when operating a power tool. Do not use a power tool while you are tired or under the influence of drugs, alcohol or medication.**

b. **Use personal protective equipment. Always wear eye protection.** Protective equipment such as dust mask, non-skid safety shoes, hard hat, or hearing protection used for appropriate conditions will reduce personal injuries.

c. **Prevent unintentional starting. Ensure the switch is in the off-position before connecting to power source and/or battery pack, picking up or carrying the tool. Carrying power tools with your finger on the switch or engaging power tools that have the switch on invites accidents.**

d. **Remove any adjusting key or wrench before turning the power tool on. A wrench or a key left attached to a rotating part of the power tool may result in personal injury.**

e. **Do not overreach. Keep proper footing and balance at all times.** This enables better control of the power tool in unexpected situations.

f. **Dress properly. Do not wear loose clothing or jewellery. Keep your hair, clothing and gloves away from moving parts.** Loose clothes, jewellery or long hair can be caught in moving parts.

GENERAL POWER TOOL SAFETY

• Only use cleaning agents designed for pressure washers. The use of other cleaning agents or chemicals may adversely affect the safety and/or operation of the appliance.

• Do not use the appliance within range of persons unless they wear protective clothing.

• High pressure jets can be dangerous if subject to misuse. The jet must not be directed at persons, animals, live electrical equipment or the appliance itself.

• Do not direct the jet against yourself or others in order to clean clothes or foot-wear.

• To ensure appliance safety, use only original spare parts from the manufacturer or approved by the manufacturer.

• High pressure hoses, fittings and couplings are important for the safety of the appliance. Use only hoses, fittings and couplings recommended by the manufacturer.

• Do not use the appliance if a supply cord or important parts of the appliance are damaged, e.g. safety devices, high pressure hoses, trigger gun.

• Water that has flowed through a back flow preventer is considered to be non-potable.

• Depending on the application, shielded nozzle can be used for high pressure cleaning, which will reduce the emission of hydrous aerosols dramatically. However, not all applications allow the use of such a device. If shielded nozzles are not applicable for the protection against aerosols, a respiratory mask of class FFP 2 or equivalent may be needed, depending on the cleaning environment.

• The electric supply connection shall be made by a qualified electrician and comply with IEC60364-1. It is recommended that the electric supply to this machine should include either a residual current device that will interrupt the supply if the leakage current to earth exceeds 30mA for 30ms or a device that will prove the earth circuit.

• Never touch the mains plug or power outlet with wet hands.

• Always disconnect the product from the power outlet when leaving the machine unattended.

• This product must not be connected to the potable water mains without back flow prevention. Check local and national plumbing regulations before connecting the machine to the potable water mains.

• Do not operate the machine at temperatures below 0 degrees.

• If an extension cord is used, it shall be suitable for outdoor use, and the connection has to be kept dry and off the ground. It is recommended that this is accomplished by means of a cord reel which keeps the socket at least 60 mm above the ground.

• It is recommended that a reinforced garden hose (with minimum diameter of 12mm) is used for the inlet connection.

• During use of high pressure cleaners, aerosols may be formed. Inhalation of aerosols can be hazardous to health.

If the supply cord is damaged, it must be replaced by an electrician or a power tool repairer in order to avoid a hazard.

Using an Extension Lead

Always use an approved extension lead suitable for the power input of this tool. Before use, inspect the extension lead for signs of damage, wear and ageing. Replace the extension lead if damaged or defective.

When using an extension lead on a reel, always unwind the lead completely. Use of an extension lead not suitable for the power input of the tool or which is damaged or defective may result in a risk of fire and electric shock.

Residual Current Device (RCD)

The pressure washer must be protected by a residual current device (rated at 30mA or less). A residual current device reduces the chance of electric shock.

g. **If devices are provided for the connection of dust extraction and collection facilities, ensure these are connected and properly used.** Use of dust collection can reduce dust-related hazards.

h. **Do not let familiarity gained from frequent use of tools allow you to become complacent and ignore tool safety principles.** A careless action can cause severe injury within a fraction of a second.

4. Power tool use and care

a. **Do not force the power tool. Use the correct power tool for your application.** The correct power tool will do the job better and safer at the rate for which it was designed.

b. **Do not use the power tool if the switch does not turn it on and off.** Any power tool that cannot be controlled with the switch is dangerous and must be repaired.

c. **Disconnect the plug from the power source and/or the battery pack from the power tool before making any adjustments, changing accessories, or storing power tools.** Such preventative safety measures reduce the risk of starting the power tool accidentally.

d. **Store idle power tools out of the reach of children and do not allow persons unfamiliar with the power tool or these instructions to operate the power tool.** Power tools are dangerous in the hands of untrained users.

e. **Maintain power tools.** Check for misalignment or binding of moving parts, breakage of parts and any other condition that may affect the power tool's operation. If damaged, have the power tool repaired before use. Many accidents are caused by poorly maintained power tools.

f. **Keep cutting tools sharp and clean.** Properly maintained cutting tools with sharp cutting edges are less likely to bind and are easier to control.

g. **Use the power tool, accessories and tool bits etc. in accordance with these instructions, taking into account the working conditions and the work to be performed.** Use of the power tool for operations different from those intended could result in a hazardous situation.

h. **Keep handles and grasping surfaces dry, clean and free from oil and grease.** Slippery handles and grasping surfaces do not allow for safe handling and control of the tool in unexpected situations.

5. Service

a. **Have your power tool serviced by a qualified repair person using only identical replacement parts.** This will ensure that the safety of the power tool is maintained.

WARRANTY

GERNI Warranty Process

Our goods come with guarantees that cannot be excluded under Australian Consumer Law. You are entitled to a replacement or refund for a major failure and for compensation for any other reasonably foreseeable loss or damage. You are also entitled to have the goods repaired or replaced if the goods fail to be of acceptable quality and the failure does not amount to a major failure.

GERNI – 1-23 Letcon Drive, Bangholme, Victoria, Australia 3175 provides the following warranty in relation to your Gerni Pressure Washer machine.

DOMESTIC WARRANTY

Definition; A machine purchased for domestic household use.

Gerni warrants that, subject to the exclusions and limitations below, the product will be free from defects in the materials and workmanship for the duration of the warranty period from the date of purchase.

2 YEAR STANDARD WARRANTY

Machines & accessories included are as follows: Gerni 3300*, 3600*, 5000*, 9000

*Subject to an additional 3 year extended warranty with online registration at www.gerni.com.au

5 YEAR STANDARD WARRANTY

Machines included are as follows: Gerni 5300*, 7000*, 7300*

*Subject to an additional 2 year extended warranty with online registration at www.gerni.com.au

2 YEAR STANDARD WARRANTY

All Gerni accessories are subject to a 2 year standard warranty, to qualify for an exchange of your product you must have proof of purchase*.

*Extended warranty is not applicable to Gerni accessories, only pressure washer machines.

GERNI Warranty Claims

Equipment defects covered by the warranty will be repaired or replaced by one of our Authorised agents within the Gerni organisation. Find your local service agent here: www.gerni.com.au

- If a fault occurs, the user must first take their pressure washer machine to the closest Gerni Authorised Agent to be diagnosed for fault. It is important that you have the pressure washer serial number accompanied with your proof of purchase receipt and a copy of your Gerni online-registration certificate to ensure your pressure washer is covered under warranty.
- If a fault is diagnosed and your machines is inside stated warranty period, then your machine will be repaired or replaced at no cost. If your machine is diagnosed faulty but your machine has fallen outside the stated warranty period, the cost of diagnosis or repair will be covered by the user.

Exclusions:

- The product has been modified, repaired, or serviced by someone other than a Gerni authorised service centre.
- The product has been used other than for the purpose to which it is designed.
- The product has been exposed to user abuse such as knocks, bumps and extreme temperatures conditions.

Gerni 3600 HIGH PRESSURE WASHER

SPECIFICATIONS

VOLTAGE:	220-240V~50-60Hz
POWER:	1500W
MAX. PRESSURE:	12.5 MPa (1810psi)
RATED PRESSURE:	9.5 MPa (1377psi)
MAX. INLET PRESSURE:	1 MPa (145 psi)
RATED FLOW:	5.4L/min
MAX. FLOW RATE:	7.7L/min
HOSE LENGTH:	6m
MAX. WATER INLET TEMP.:	40°C
IP RATING:	IPX5
WEIGHT:	6.6kg

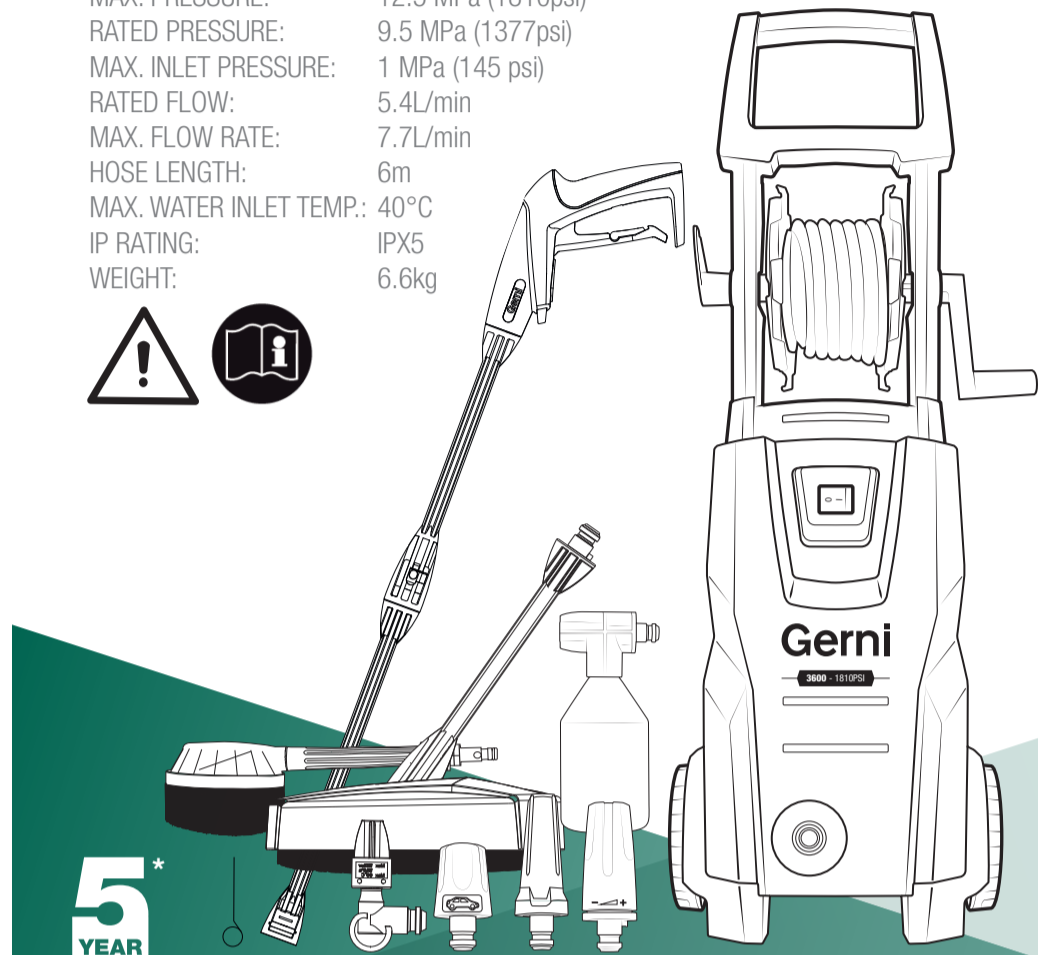

5
YEAR
WARRANTY

2 Year Standard
4.3 Year Extended

Gerni 1-23 LETCON DRIVE, BANGHOLME, VICTORIA, AUSTRALIA 3175.

GPW-3600

Gerni 1-23 LETCON DRIVE, BANGHOLME, VICTORIA, AUSTRALIA 3175.

0820

COMPONENTS

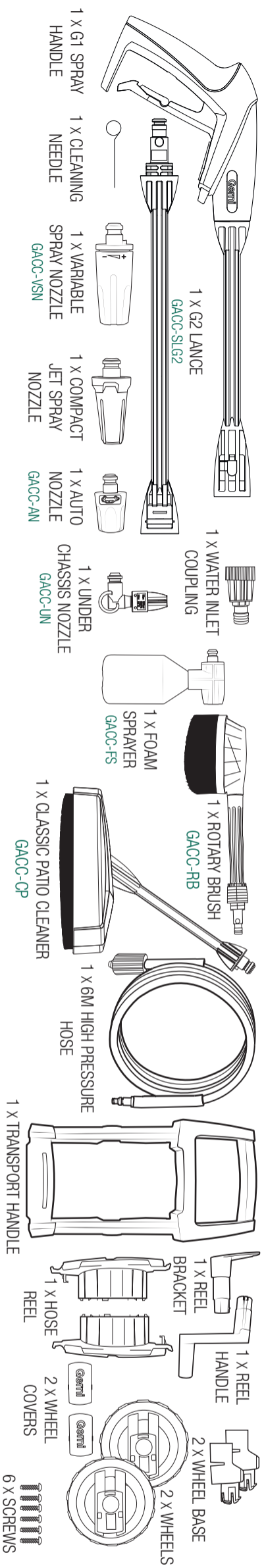

A

HOSE REEL

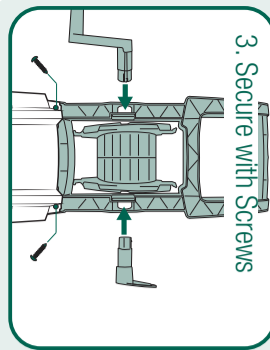
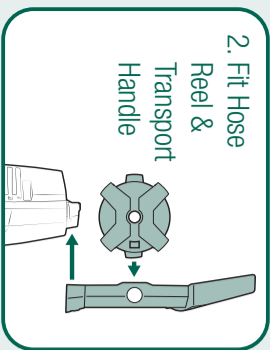
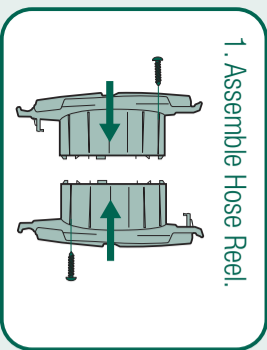

C

ATTACH INLET COUPLING

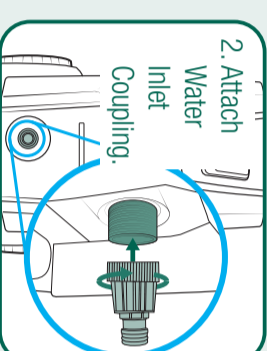
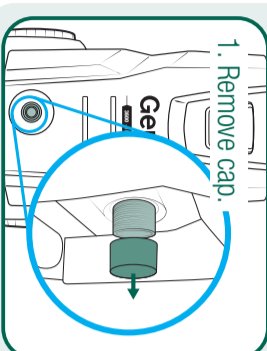

D

SETUP HIGH PRESSURE HOSE

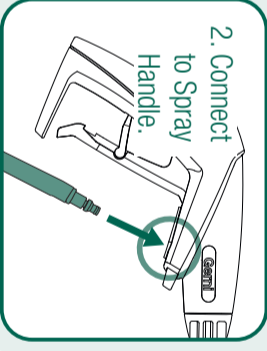
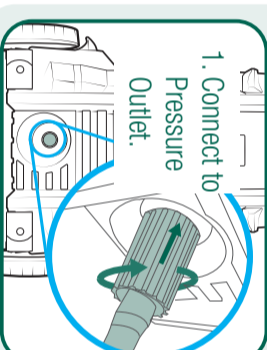

E

ASSEMBLE SPRAY GUN

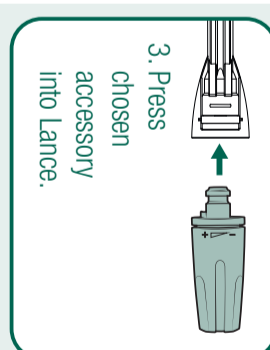
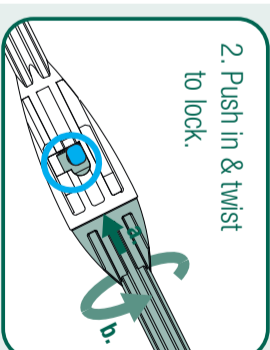
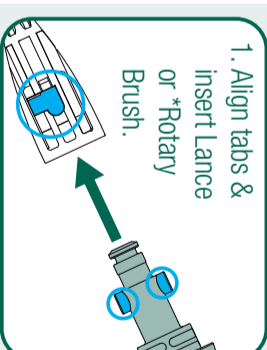

F

FIT AN ACCESSORY

VARIABLE SPRAY NOZZLE GACC-VSN

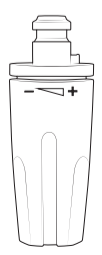

- Everyday general cleaning.
- Twist to adjust 0-15° spray.

COMPACT JET SPRAY NOZZLE

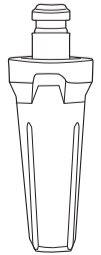

- For removing ingrained dirt.
- High impact rotating jet spray.
- Covers a large area.

AUTO NOZZLE GACC-AN



- Gently cleans painted surfaces.
- 60° Spray.
- For cars, motorcycles & bicycles.

UNDER CHASSIS NOZZLE GACC-UN

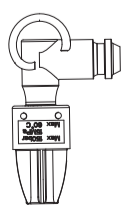

- Under-body cleaning.
- For cars, boats and caravans.

ROTARY BRUSH GACC-RB



- *** Fits SPRAY HANDLE (Twist lock).**
- For cars and boats.
- Gentle on painted surfaces.

CLASSIC PATIO GACC-CP

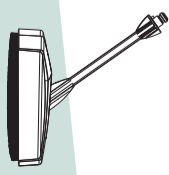

- For cleaning horizontal surfaces.
- Suitable for brick, cement & wood.

B

WHEEL ASSEMBLY

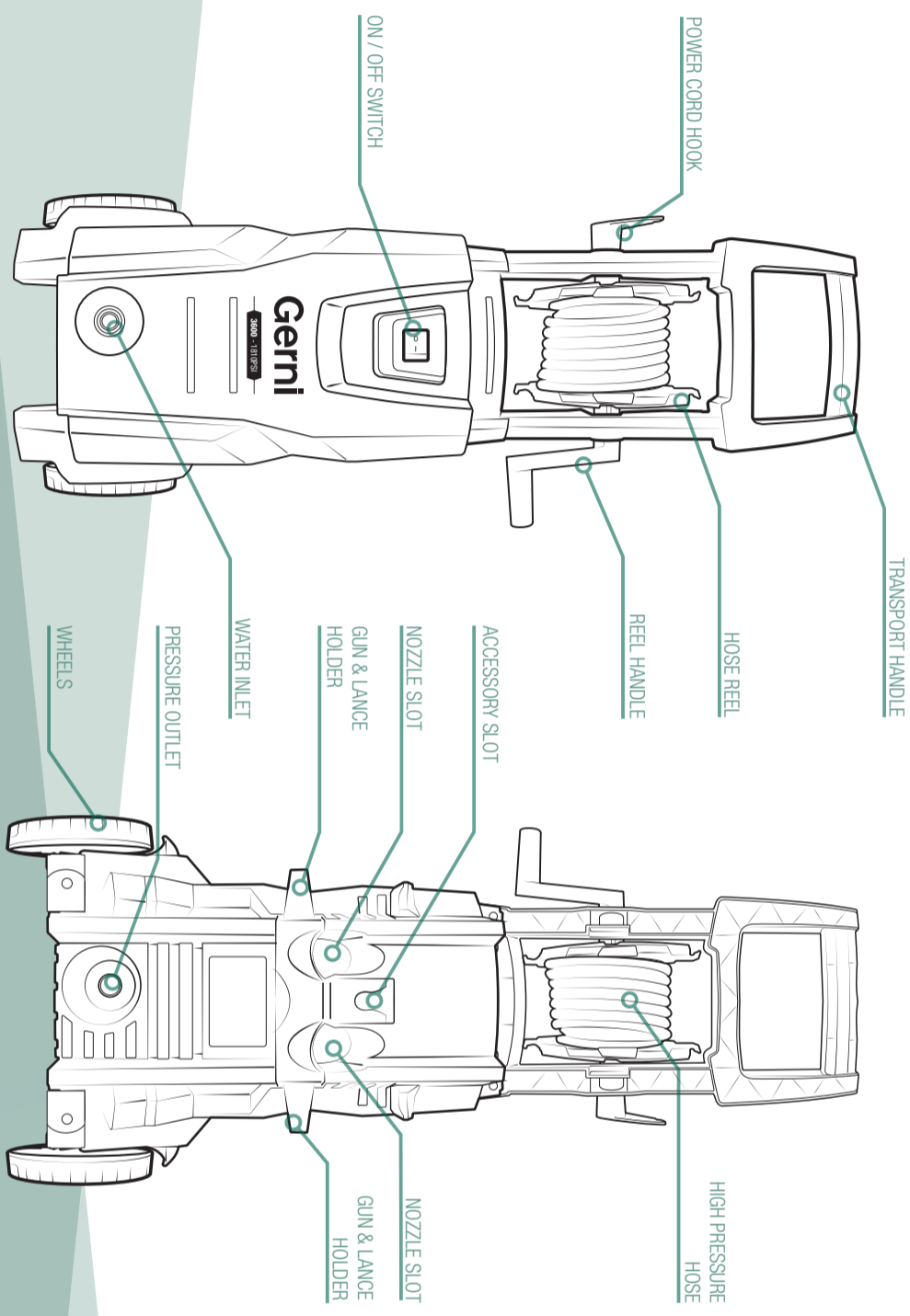
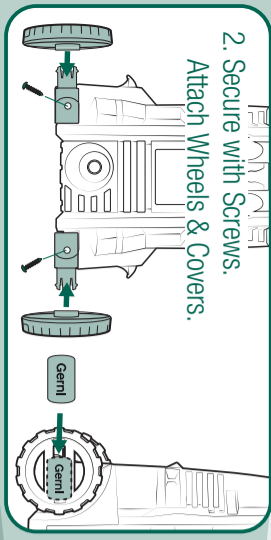
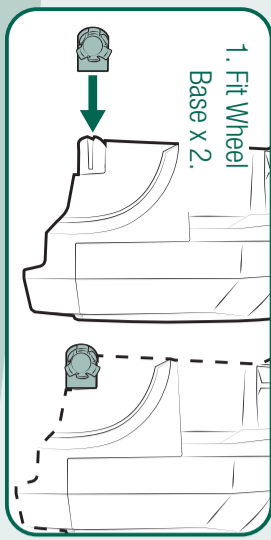

CONNECT TO TAP

WARNING! High pressure jets can be dangerous if not used properly. Do not direct the jet at persons, animals, live electrical equipment or the pressure washer itself.

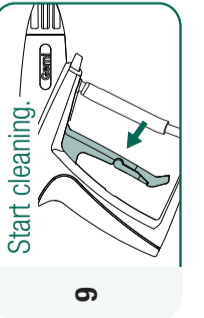
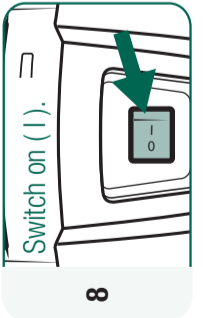
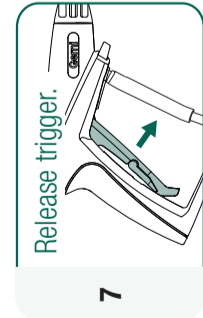
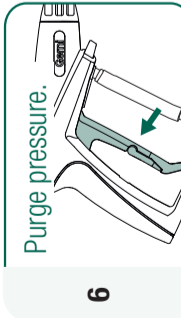
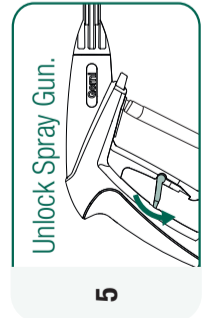
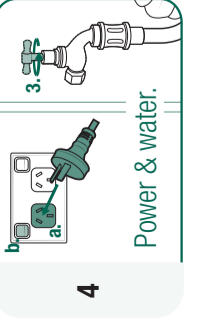
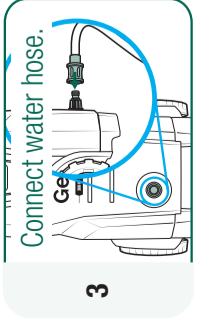
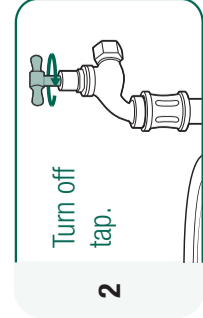
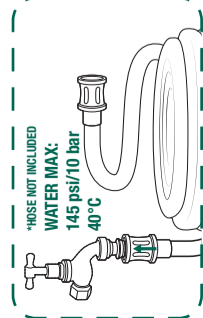

TAKE A BREAK

WARNING! High pressure jets can be dangerous if not used properly. Do not direct the jet at persons, animals, live electrical equipment or the pressure washer itself.

WARNING! Perform the procedure below if taking a break for more than 5 minutes. Failure to do so may damage the pump or cause the equipment to overheat and malfunction.

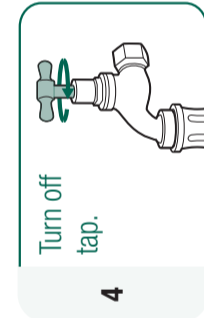
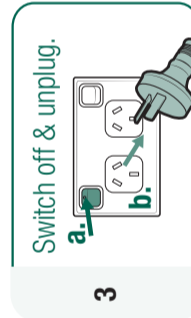
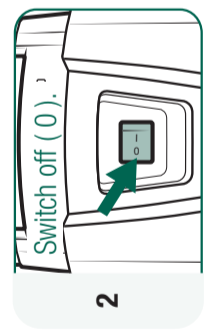
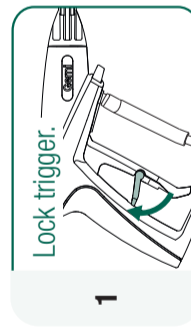

NOT WORKING?

SYMPTOM	POSSIBLE CAUSE	RECOMMENDED ACTION
Fluctuating Pressure	Pump is drawing in air Insufficient water supply	Check that hoses and connections are airtight Increase water supply at the tap, check for blockages or kinks in the hose and/or swap to a larger diameter hose
The machine stops mid-use	Accessory nozzle dirty or blocked Incorrect mains voltage Thermal sensor activated Nozzle partially blocked	Clean accessory nozzle bore as there may be a blockage from dirt or debris please use cleaning needle provided Check that the mains voltage corresponds to the specification on the model tag Leave pressure washer for 5 minutes to cool down Please refer to Care & Cleaning (step 5) section of the user manual
Machine Pulsating/inconsistent spray	Air in the inlet hose/pump Kinked water hose	Press & hold the spray gun trigger and allow the machine to run until normal working pressure resumes Unwind the water hose fully
No water emitted	Insufficient water supply Water filter blocked Blocked nozzle	Increase water supply at the tap, check for blockages or kinks in the hose and/or swap to a larger diameter hose. Clean the inlet filter
Machine often starts and stops by itself	Spray gun may be leaking due to worn/damaged O-ring	Use cleaning needle to clean outlet Please contact your closest Gerni Authorised Repair Agent www.gerni.com.au

STORAGE

- 1 Turn off tap.
- 2 Switch off (0).
- 3 Drain water from Spray Gun.
- 4 Remove water hose.
- 5 Disconnect Spray Gun.
- 6 Switch on (1).
- 7 Drain High Pressure Hose.
- 8 Switch off (0).
- 9 Disconnect High Pressure Hose.
- 10 Switch off & unplug.
- 11 Dry parts before storage.









CARE & CLEANING

! WARNING! Ensure the tool is turned off and disconnected from the power supply before performing any of the following operations.

- 1 Switch off (0).
- 2 Switch off & unplug.
- 3 Disassemble accessories.
- 4 Rinse accessories.
- 5 Clean Nozzles.
- 6 Remove Water Inlet Coupling & Filter.
- 7 Rinse Inlet Filter.
- 8 Dry parts before storage.

INSPECT & REPLACE IF DAMAGED

DEFINITIONS

	Read instruction manual
	Double insulated
	Regulatory compliance mark
	Warning!
	Wear eye protection
	Wear gloves
	Not suitable for connection to potable water mains
	Warning! High pressure jets can be dangerous if not used properly. Do not direct the jet at persons, animals, live electrical equipment or the pressure washer itself
V	Volts
Hz	Hertz
~	Alternating Current
W	Watts
L/min	Litres per minute
psi	Pounds per square inch
Mpa	Mega Pascals
IPX5	Ingress protection from water

DISPOSAL ADVICE

POWER TOOL
Power tools that are no longer usable should not be disposed of with household waste but in an environmentally friendly way. Please recycle where facilities exist. Check with your local council authority for recycling advice.

PACKAGING
Recycling packaging reduces the need for landfill and raw materials. Reuse of recycled material decreases pollution in the environment. Please recycle packaging where facilities exist. Check with your local council authority for recycling advice.

NEED HELP?

 www.gerni.com.au

 customerservice@gerni.com.au

 **AUS** 1300 162 689
NZ 0800 700 124