

SANIPACK / SANINSIDE

126

05.13

# SFA

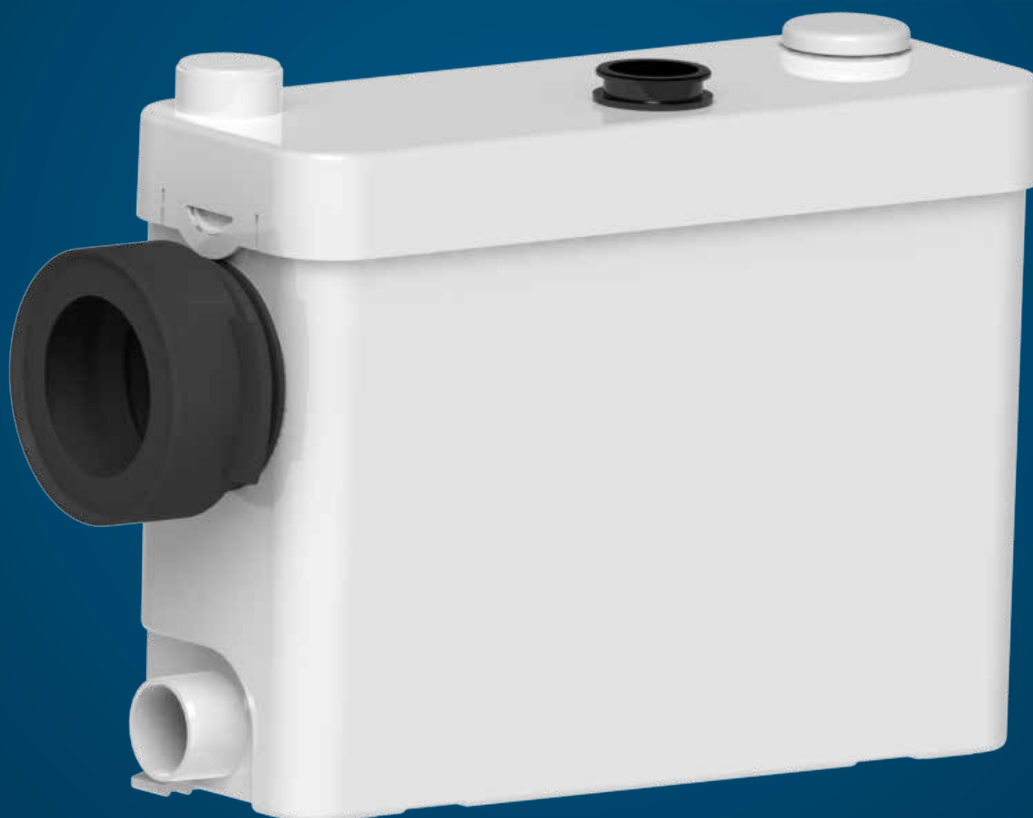

**SANIPACK®/SANINSIDE®**

**FR** NOTICE D'INSTALLATION

**UK** INSTALLATION INSTRUCTIONS

**DE** INSTALLATIONSHINWEISE

**IT** STRUZIONI PER L'INSTALLAZIONE

**ES** MANUAL DE INSTALACIÓN

**PT** MANUAL DE INSTALAÇÃO

**NL** INSTALLATIE VOORSCHRIFTEN

**SE** INSTALLATIONSANVISNING

**DK** INSTALLATIONSVEJLEDNING

**NO** INSTALLASJONSANVISING

**FI** ASENNUSOHJEET

**HU** FELSZERELÉSI ÉS KEZELÉSI ÚTMUTATÓ

**PL** INSTRUKCJA INSTALACJI

**RU** ИНСТРУКЦИЯ ПО МОНТАЖУ И ЭКСПЛУАТАЦИИ

**RO** MANUAL DE INSTALARE

**CZ** NÁVOD K INSTALACI A POUŽÍVÁNÍ

**TR** KURULUM KILAVUZU

**EL** ΟΔΗΓΙΕΣ ΕΓΚΑΤΑΣΤΑΣΗΣ

**CN** 用户应保留安装指南以备

**KR** 설치내용서

CE

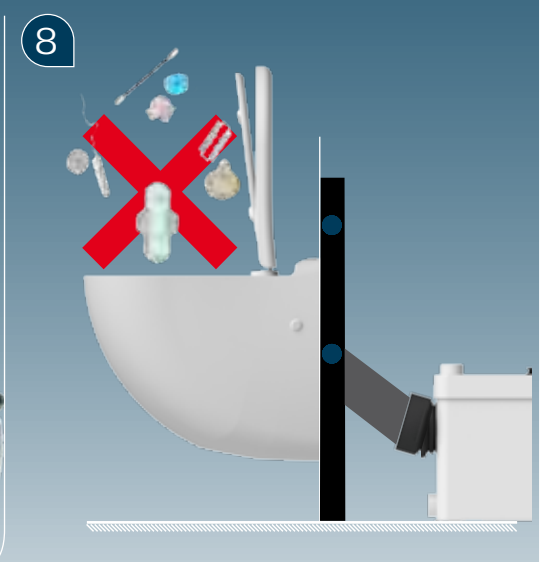
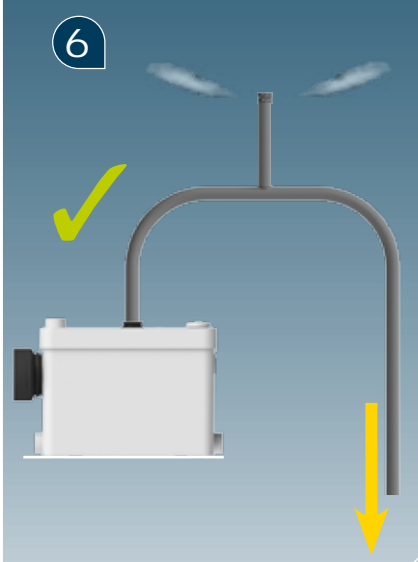
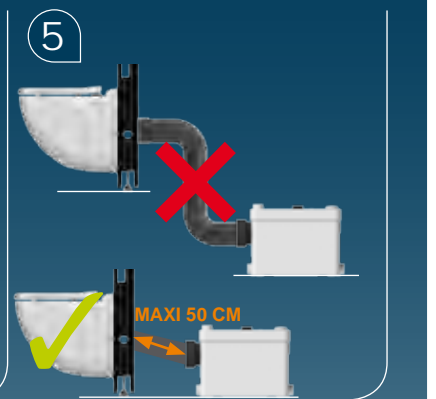
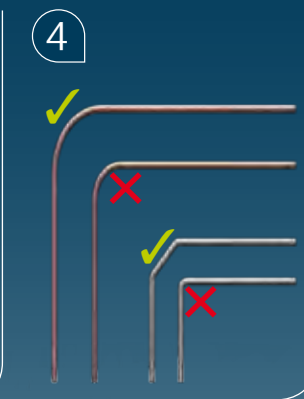
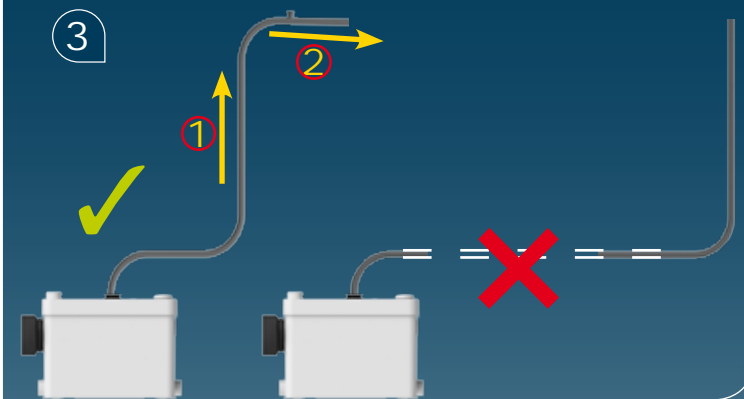
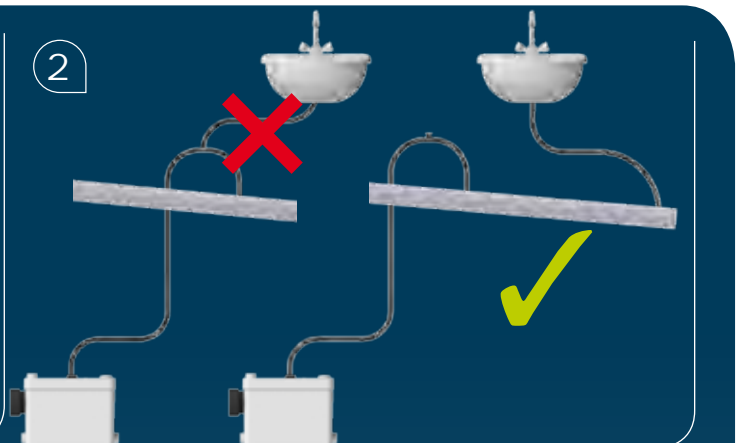
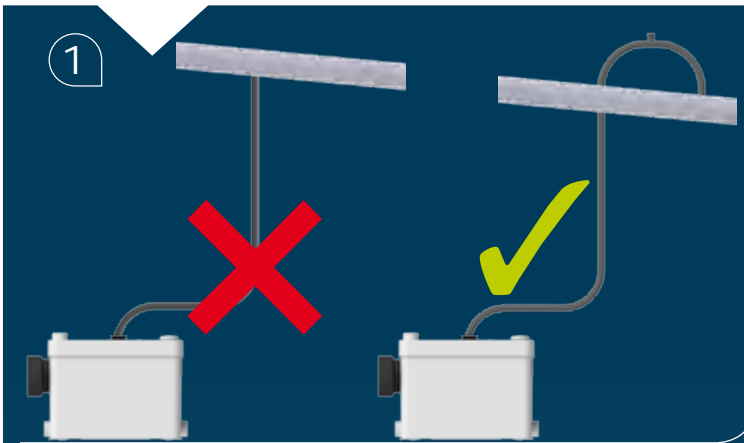
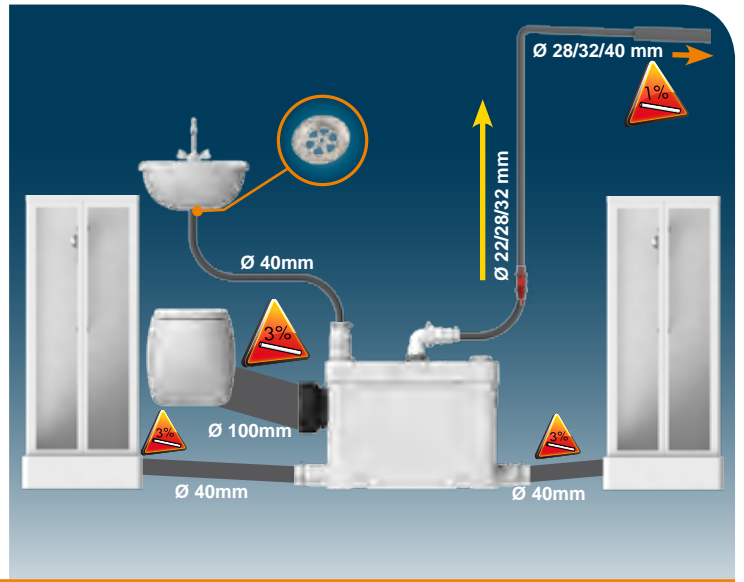
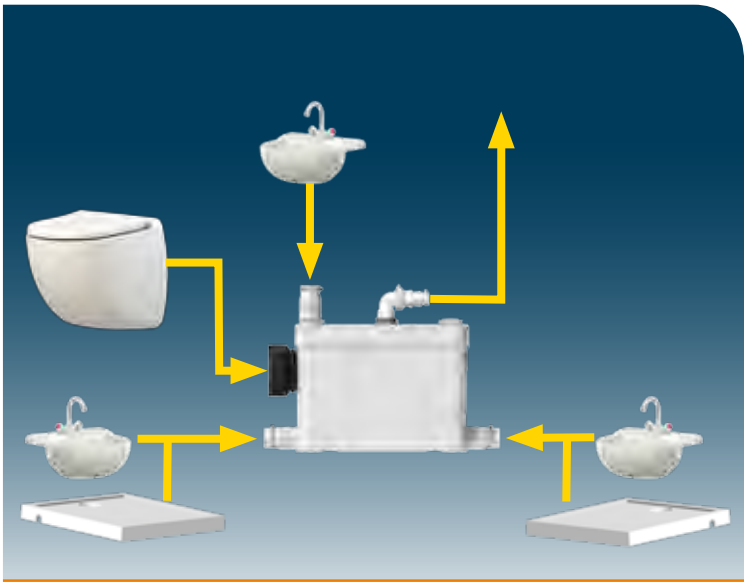

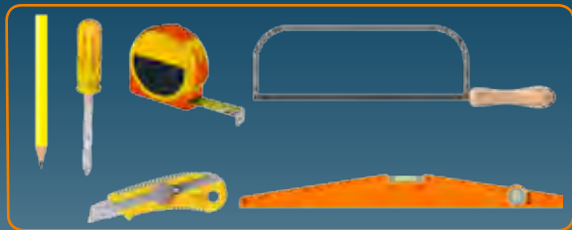
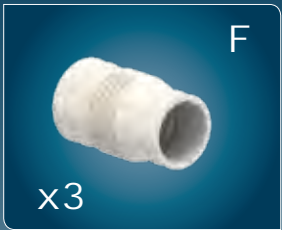
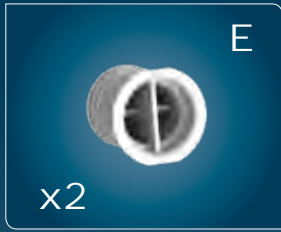
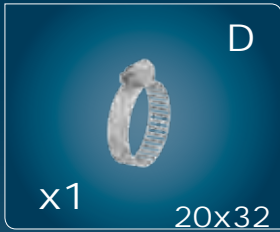
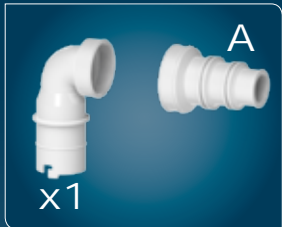

1

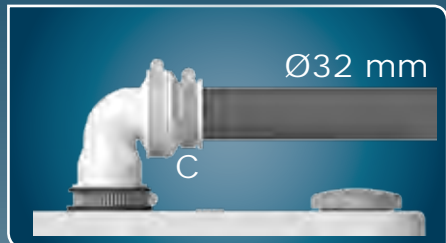
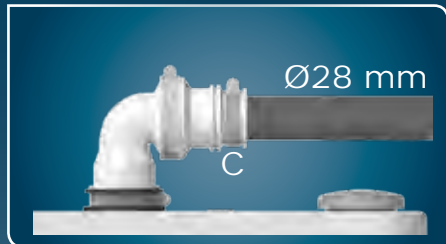
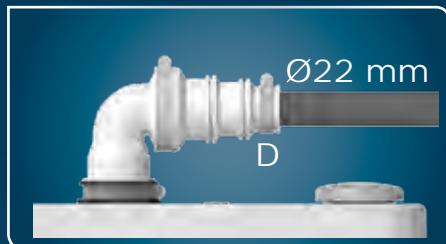
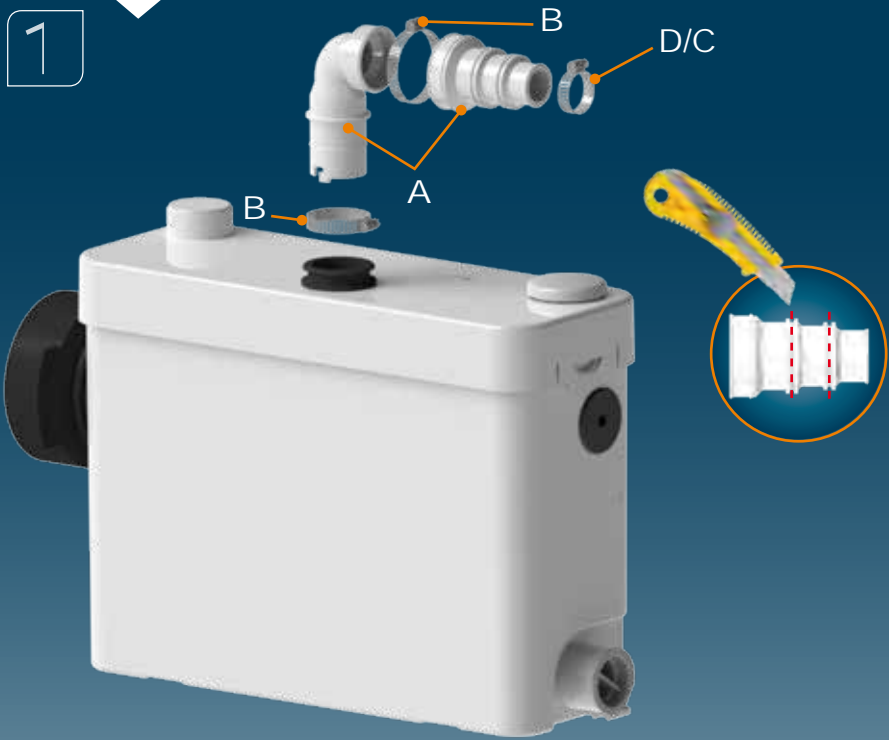

2

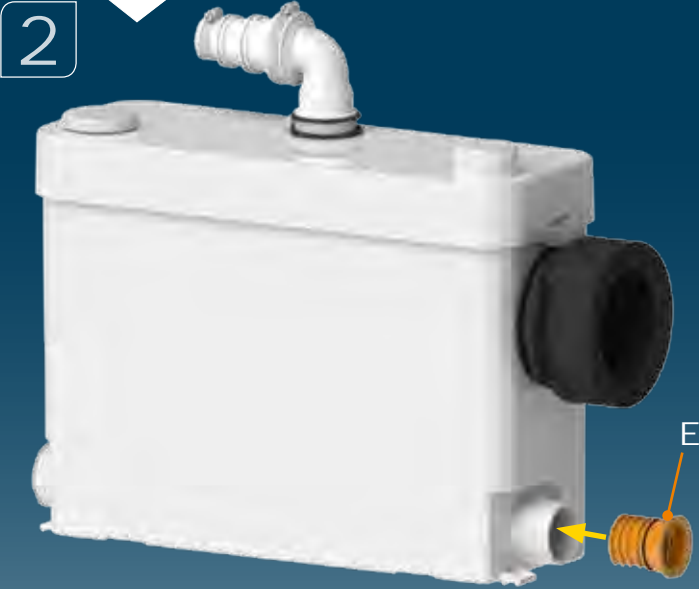

3



4

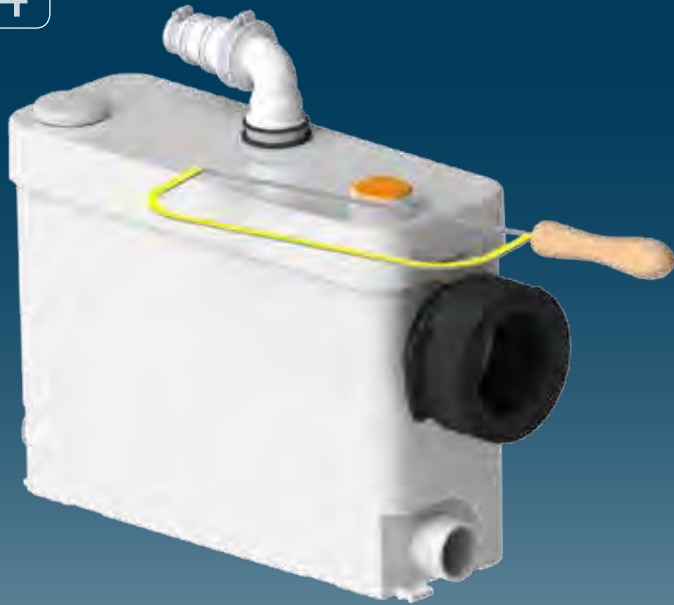

5

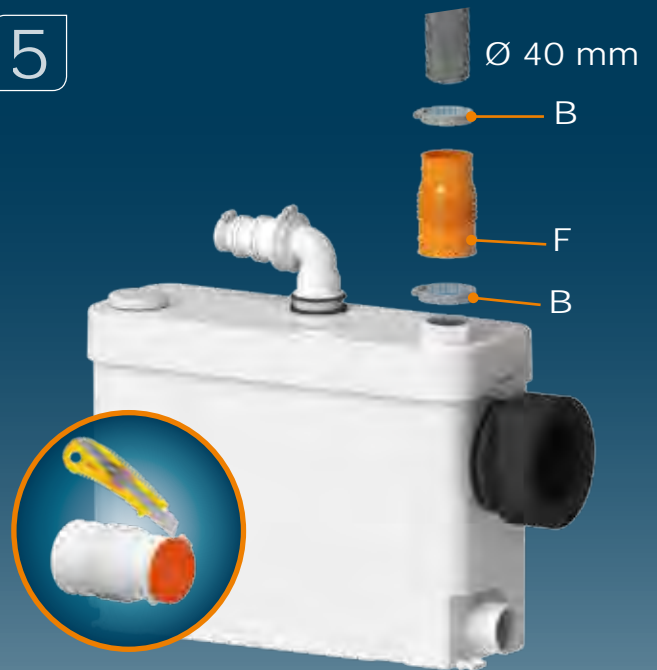

6

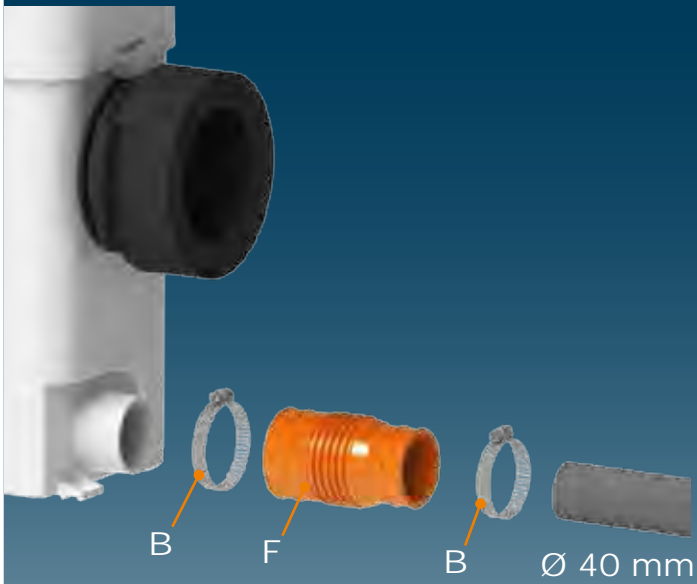

7

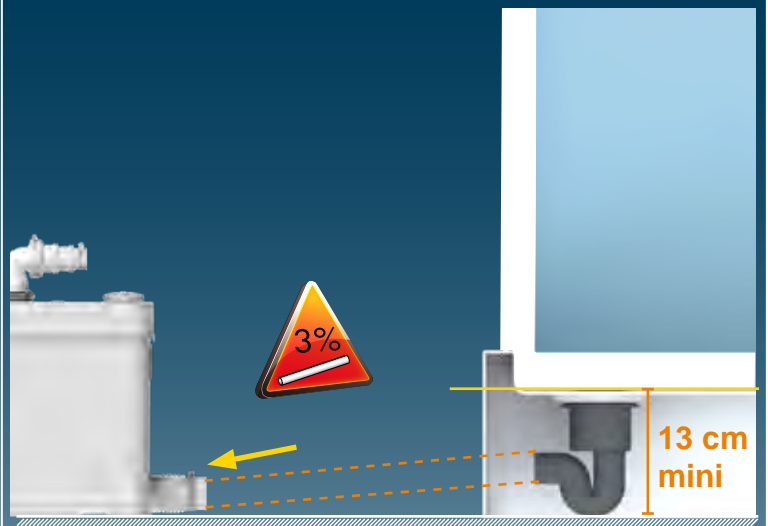

8

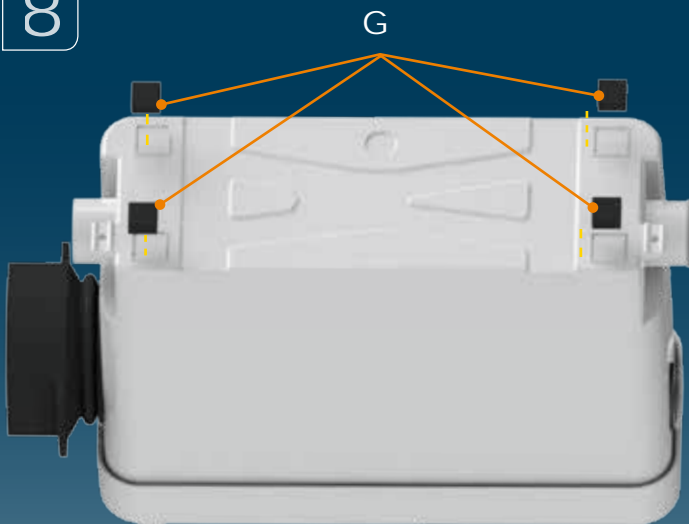

9



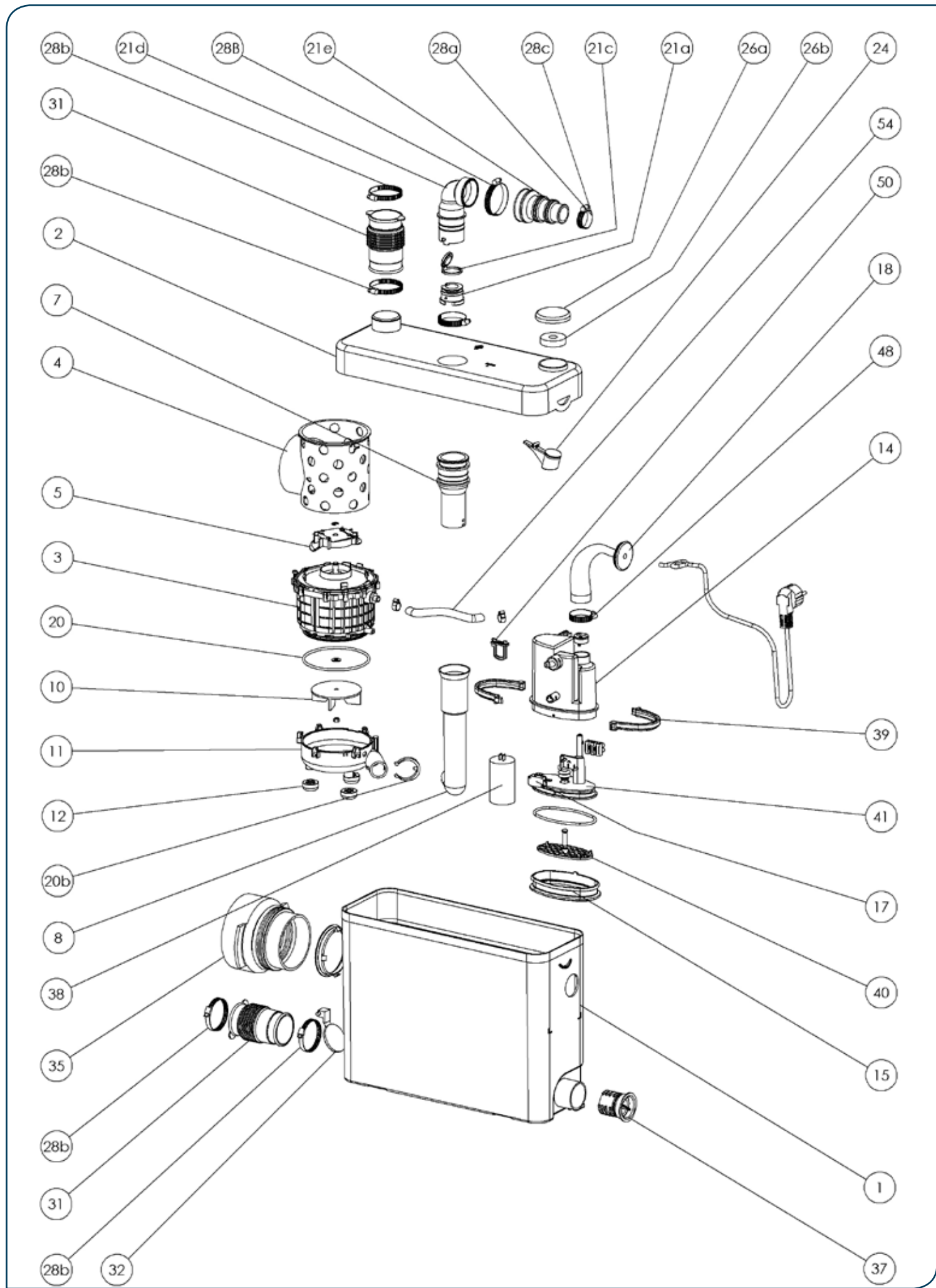



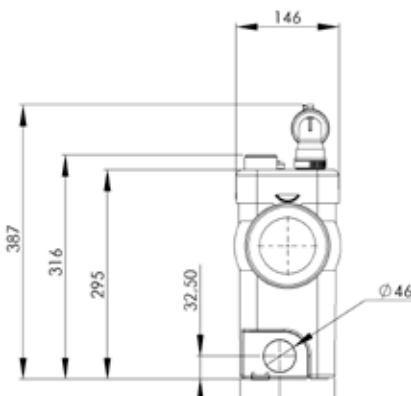
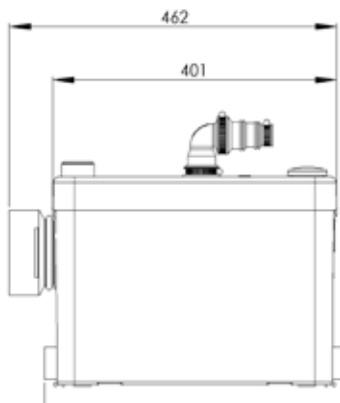
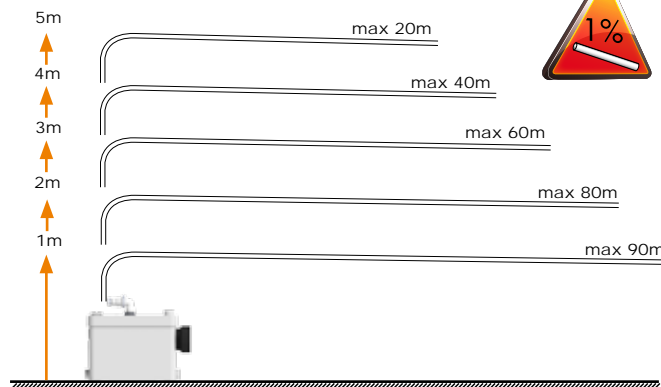
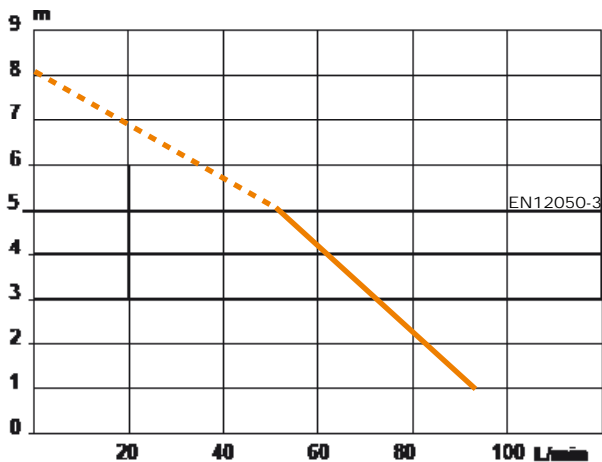

## SANIPACK/SANINSIDE

**EN 12050-3**

**P 30**

**220-240 V - 50 Hz - 1,9A**

**400 W - IP44**

**⚡ (class 1)**

### FRANCE

**SOCIÉTÉ FRANÇAISE  
D'ASSAINISSEMENT**  
8, rue d'Aboukir - 75002 Paris  
Tél. +33 1 44 82 39 00  
Fax +33 1 44 82 39 01

### UNITED KINGDOM

**SANIFLO Ltd.,**  
Howard House, The Runway  
South Ruislip Middx.,  
HA4 6 SE  
Tel. +44 208 842 0033/4040  
Fax +44 208 842 1671

### IRELAND

**SANIRISH Ltd**  
IDA Industrial Estate  
Edenderry - County Offaly  
Tel. + 353 46 9733 102  
Fax + 353 46 97 33 093

### AUSTRALIA

**SANIFLO AUSTRALIA**  
Unit 9/10, 25 Gibbes Street Pty Ltd  
Chatswood NSW 2067  
Tel. +61 298 826 200  
Fax +61 298 826 950

### DEUTSCHLAND

**SFA SANIBROY GmbH**  
Waldstr. 23 Geb. B5 - 63128  
Dietzenbach CH-8954  
Tel. (060 74) 30928-0  
Fax (060 74) 30928-90

### ITALIA

**SFA ITALIA spa**  
Via del Benessere, 9  
27010 Siziano (PV)  
Tel. 03 82 61 81  
Fax 03 82 61 8200

### ESPAÑA

**GRUPO SFA**  
C/ Vinyalets, 1 - Pl. Can Vinyalets  
08130 Sta. - Perpètua de Mogoda -  
Barcelona  
Tel. +34 93 544 60 76  
Fax +34 93 462 18 96

### PORTUGAL

**SFA, Lda.**  
Sintra Business Park, ed.01-1ªP  
2710-089 SINTRA  
Tel. +351 219 112 785  
Fax +351 219 577 000

### РОССИЯ

**SFA РОССИЯ**  
101000 Москва - Колпачный пер.9а,  
Тел. (495) 258 29 51  
факс: (495) 258 29 51

### SUISSE SCHWEIZ SVIZZERA

**SFA SANIBROY AG**  
Steinhaldestrasse 28  
Geroldswill CH-8954  
Tel. +41 44 748 17 44  
Fax +41 44 748 17 43

### BENELUX

**SFA BENELUX B.V.**  
Voltaweg 4  
6101 XK Echt  
Tel. +31 475 487100  
Fax +31 475 486515

### SVERIGE

**SANIFLO AB**  
BOX 797  
S-191 27 Sollentuna  
Tel. +08-404 15 30  
Fax + 08-404 15 39

### POLSKA

**SFA POLAND**  
ul. Kolejowa 33  
05-092 Łomianki/Warszawa  
Tel. (+4822) 732 00 32  
Fax (+4822) 751 35 16

### ČESKÁ REPUBLIKA

**SFA-SANIBROY, spol. s r.o.**  
Na Košince - 180 00 PRAHA 8 - Libeň  
Tel. +420 266 712 855  
Fax, +420 266 712 856

### ROMANIA

**SFA SANIFLO S.R.L.**  
Strada Leonard Nicolae, nr. 2A  
Timișoara 300454  
Tel. +40 256 245 092  
Fax +40 256 245 029

### TÜRKIYE

**SFA SANIHYDRO LTD STI**  
Ortaklar Caddesi No:7 Ünal Apt. D: 2  
34394 MECIDIYEKÖY - İSTANBUL  
Tel. +90 212 275 30 88  
Fax, +90 212 275 90 58

### CHINA

**SFA 中国**  
上海市静安区石门二路333弄3号振安  
广场恒安大厦27C室 (200041)  
T: +86(0)21 6218 8969  
F: +86(0)21 6218 8970

### KOREA

**www.SFA.biz**  
sales@saniflo-korea.kr

## SERVICE HELPLINES

	TEL	FAX	TEL	FAX
France	08 810 05 90 02	03 44 94 46 19	Benelux	+31 475 487100
United Kingdom	08457 650011 (Call from a land line)	020 8842 1671	Sverige	08-744 15 18
Ireland	1850 23 24 25 (LOW CALL)	+ 353 46 97 33 093	Norge	+47 951 61 131
Australia	+61 298 826 200	+61 298 826 950	Polyska	(+4822) 732 00 33
Deutschland	0800 82 27 82 0	(060 74) 30928-90	Россия	(495) 258 29 51
Italia	0382 6181	+39 0382 618200	Česká Republika	+420 266 712 855
España	+34 93 544 60 76	+34 93 462 18 96	România	+40 256 245 092
Portugal	+351 219 112 785	+351 219 577 000	Türkiye	+90 212 275 30 88
Suisse Schweiz Svizzera	+41 44 748 17 44	+41 44 748 17 43	中国	+86(0)21 6218 8969
				+86(0)21 6218 8970

Service information : [www.sfa.biz](http://www.sfa.biz)

## 1 DESCRIPTION

This macerator is (manufactured in a factory which is quality) certified to ISO 9001. Installed and used correctly, the unit will give consistent and reliable service.

**This device is not designed for persons (including children) with limited physical, sensory or mental abilities, or those with minimal experience and knowledge, unless they are monitored and are given the necessary instructions for using the device, with the help of a person responsible for their safety. Monitor children and make sure they do not play with the device.**

## 2 APPLICATIONS

This appliance is a compact lift pump unit designed for removing waste water from a horizontal outlet toilet\*, shower\*, bidet\* or washbasin\* (\*: depending on the model). This appliance conforms to EN 12050-3 and the European standards concerning electrical safety and electromagnetic compatibility.

## 3 INSTALLATION

The unit should be accessible for possible service.

The fitting and working of your appliance must meet local regulations and the EN 12056-4 standard.

To optimise the latest technical developments concerning soundproofing incorporated into this unit, it is important to:

- position the WC pan so that it is not in contact with a partition or wall of the room
- place the WC pan on a perfectly level surface to ensure that the resilient mounts are fully efficient
- fix the discharge pipe correctly, with distances of not more than one metre between the fastenings.

### CONNECTION TO THE ELECTRICAL SUPPLY

**The electrical installation should be carried out by a qualified person. The unit requires a 220/240V single phase AC 50 Hz supply (UK specification). The power supply circuit of the appliance must be earthed (Class I) and protected by a GFCI high sensitivity (30mA). Warning: Ensure the electricity is turned OFF at the main switch board before wiring to connector.**

All wiring must conform to BS7671, 1992 requirements for electrical installations. Do not connect the unit to a conventional plug and socket. **It must be wired into a fused, unswitched, fixed wiring connector fitted with a 5 amp fuse.** The wires in the mains lead are coloured in accordance with

the following code:

- Brown - Live
- Blue - Neutral
- Green/Yellow - Earth

The connection must be used exclusively to power the device.

All work on cable, pressure chamber and motor should only be carried out by a qualified Saniflo servicing agent, as special tools are required. Please do not cut/shorten the electrical supply cable which can make it very difficult to remove in the event of a service requirement.

## 4 COMMISSIONING THE UNIT

Flush the WC checking that all seals, and connections are watertight.

Check both the discharge pipework from the unit and the other sanitary appliances connections. Check the watertightness of connections to sanitary appliances:

toilet\*, shower\*, bidet\* or washbasin\* (\*: depending on the model).

## 5 MAINTENANCE

**WARNING !!!** In the event of prolonged absence it is essential to turn off the water supply to protect the installation against sub zero temperatures.

### CARE OF YOUR UNIT

In order to remove scale and clean the macerator and the bowl, use the SANIFLO Cleanser/Descaler.

- .Disconnect the macerator power supply,
  - .Pour an amount of cleanser into the pan
  - .Leave it to stand for 1 or 2 hours,
  - .Re-connect the macerator power supply,
  - .Rinse by operating the flushing system twice.
- Carry out the operation once every 3 months on average, but the frequency may need to be changed depending on the hardness of the water.

## 6 FAULT FINDING / REMEDIES

### IN ALL CASES, YOU MUST DISCONNECT THE MACERATOR FROM THE POWER SUPPLY

SYMPTOMS	PROBABLE CAUSES	REMEDIES
<ul style="list-style-type: none"> <li>• The motor does not activate</li> </ul>	<ul style="list-style-type: none"> <li>• <i>The electrical power supply is not active</i></li> <li>• <i>The electrical power supply is defective</i></li> <li>• <i>The motor or the control system is defective</i></li> </ul>	<ul style="list-style-type: none"> <li>• Restore the electrical supply</li> <li>• Check the electrical power supply</li> <li>• Otherwise, ask an approved repair agent to intervene</li> </ul>
<ul style="list-style-type: none"> <li>• The motor emits a rattling or crunching sound, hums, but does not run</li> </ul>	<ul style="list-style-type: none"> <li>• Foreign object into the box</li> <li>• <i>Problem with the motor or the control system</i></li> </ul>	<ul style="list-style-type: none"> <li>• Remove the foreign body</li> <li>• Otherwise, ask an approved repair agent to intervene</li> </ul>
<ul style="list-style-type: none"> <li>• The motor intermittently activates</li> </ul>	<ul style="list-style-type: none"> <li>• <i>The connected sanitary devices are dripping water</i></li> <li>• <i>The non-return valve is faulty</i></li> </ul>	<ul style="list-style-type: none"> <li>• Check the installation upstream</li> <li>• Clean or replace the non-return valve</li> </ul>
<ul style="list-style-type: none"> <li>• The motor operates normally, but continues to run for a long time</li> </ul>	<ul style="list-style-type: none"> <li>• <i>The length or height of the installation is over the specification, or there are too many bends/elbows</i></li> <li>• <i>The pump cover plate is partially obscured/blocked</i></li> </ul>	<ul style="list-style-type: none"> <li>• Check the installation</li> <li>• Otherwise, ask an approved repair agent to intervene</li> </ul>
<ul style="list-style-type: none"> <li>• The unit stops</li> </ul>	<ul style="list-style-type: none"> <li>• <i>The unit has been running for too long (thermal cut-out)</i></li> </ul>	<ul style="list-style-type: none"> <li>• Wait for reset, then ask an approved repair agent to intervene</li> </ul>
<ul style="list-style-type: none"> <li>• Motor is surging and water in the WC pan goes down very slowly</li> </ul>	<ul style="list-style-type: none"> <li>• <i>The air dispenser is clogged up</i></li> <li>• <i>Problem with motor</i></li> </ul>	<ul style="list-style-type: none"> <li>• Clear the air relief hole</li> <li>• Otherwise, ask an approved repair agent to intervene</li> </ul>
<ul style="list-style-type: none"> <li>• Cloudy water comes up into the shower basin (units with side inlets)</li> </ul>	<ul style="list-style-type: none"> <li>• <i>Shower installed too low as compared with the macerator unit</i></li> <li>• <i>Hinged side inlet discs clogged up</i></li> </ul>	<ul style="list-style-type: none"> <li>• Check the installation</li> <li>• Clean the hinged discs</li> <li>• Otherwise, ask an approved repair agent to intervene</li> </ul>

## 7 GUARANTEE

**2 years guarantee as from its date of purchase subject to correct installation and correct use.**

**Only the disposal of toilet paper, faecal matter, and waste water will be under guarantee. Any damage due to foreign bodies such as cotton, condoms, sanitary towels, wet wipes, food, hair, metal, wood or plastic objects, will not be under guarantee. Solvents, acids and other chemicals can also cause damage to the unit, and will invalidate the guarantee.**







**FRANCE****SOCIÉTÉ FRANÇAISE  
D'ASSAINISSEMENT**

8, rue d'Aboukir - 75002 Paris  
Tél. + 33 1 44 82 39 00  
Fax + 33 1 44 82 39 01

**UNITED KINGDOM****SANIFLO Ltd.,**

Howard House, The Runway  
South Ruislip Middx.,  
HA4 6SE  
Tel. +44 208 842 0033/4040  
Fax +44 208 842 1671

**IRELAND****SANIRISH Ltd**

IDA Industrial Estate  
Edenderry - County Offaly  
Tel. + 353 46 9733 102  
Fax + 353 46 97 33 093

**AUSTRALIA****SANIFLO (Australasia) Pty Ltd**

Unit 9-10, 25 Gibbs Street  
Chatswood  
NSW 2067  
Tel. +61 298 826 200  
Fax +61 298 826 950

**DEUTSCHLAND****SFA SANIBROY GmbH**

Waldstr. 23 Geb. B5 - 63128 Dietzenbach  
Tel. (060 74) 30928-0  
Fax (060 74) 30928-0

**ITALIA****SFA ITALIA spa**

Via del Benessere, 9  
27010 Sizzano (PV)  
Tel. 03 82 61 81  
Fax 03 82 61 8200

**ESPAÑA****SFA SI**

C/ Vinyalets,1 - P.I. Can Vinyalets  
08130 Sta. - Santa Perpètua de Mogoda -  
Barcelona  
Tel. +34 93 544 60 76  
Fax +34 93 462 18 96

**PORTUGAL****SFA, Lda.**

Sintra Business Park, ed.01-1ºP  
2710-089 Sintra  
Tel. +35 21 911 27 85  
Fax. +35 21 957 70 00

**SUISSE SCHWEIZ SVIZZERA****SFA SANIBROY AG**

Steinhaldenstrasse 28  
CH - 8954 Geroldswil  
Tel. +41 44 748 17 44  
Fax: +41 44 748 17 43

**BENELUX****SFA BENELUX B.V.**

Voitaweg 4  
6101 XK Echt (NL)  
Tel. +31 475 487100  
Fax +31 475 486515

**SVERIGE****SANIFLO AB**

BOX 797  
S-191 27 Sollentuna  
Tel. +08-404 15 30  
Fax + 08-404 15 39

**POLSKA****SFA POLAND**

ul. Kolejowa 33  
05-092 Łomianki/Warszawa  
Tel. (+4822) 732 00 32  
Fax (+4822) 751 35 16

**РОССИЯ****SFA РОССИЯ**

101000 Москва - Колпачный пер.  
9а  
Тел. (495) 258 29 51  
факс (495) 258 29 51

**ČESKÁ REPUBLIKA****SFA SANIBROY, spol. s r.o**

Na Košince - 180 00 PRAHA 8 - Libeň  
Tel. : +420 266 712 855  
Fax : +420 266 712 856

**ROMANIA****SFA SANIFLO S.R.L.**

Strada Leonard Nicolae, nr. 2A  
Timis,oara 300454  
Tel. +40 256 245 092  
Fax +40 256 245 029

**TÜRKİYE****SFA SANIHYDRO LTD ŞTİ**

Ortaklar Caddesi No:7 Ünal Apt. D: 2  
34394 MECIDIYEKÖY - İSTANBUL  
Tel. : +90 212 275 30 88  
Fax : +90 212 275 90 58

**CHINA****SFA 中国**

上海市静安区石门二路333弄3号振安广场  
恒安大厦27C室 (200041)  
Tel. +86(0)21 6218 8969  
Fax +86(0)21 6218 8970

**KOREA**

www.sfa-korea.com  
sales@saniflo-korea.kr

**SERVICE HELPLINES****France****United Kingdom****Ireland****Australia****Deutschland****Italia****España****Portugal****Suisse Schweiz Svizzera****Benelux****Sverige****Norge****Polska****Россия****Česká republika****România****Türkiye****中国****TEL**

☎ **N°Azur 0 810 05 90 02** 1 UT par appel

08457 650011 (Call from a land line)

1850 23 24 25 (LOW CALL)

+61 3 9543 3891

0800 82 27 82 0

0382 6181

+34 93 544 60 76

+35 21 911 27 85

+41 44 748 17 44

+31 475 487100

08-404 15 30

(+47) 951 61 131

(+4822) 732 00 33

(495) 258 29 51

+420 266 712 855

+40 256 245 092

+90 212 275 30 88

+86(0)21 6218 8969

**FAX**

03 44 94 46 19

020 8842 1671

+ 353 46 97 33 093

+61 3 9543 6851

(060 74) 30928-90

+39 0382 618200

+34 93 462 18 96

+35 21 957 70 00

+41 44 748 17 43

+31 475 486515

08-404 15 39

(+4822) 751 35 16

(495) 258 29 51

+420 266 712 856

+40 256 245 029

+90 212 275 90 58

+86(0)21 6218 8970

**Service information : [www.sfa.biz](http://www.sfa.biz)**