

ASSEMBLY INSTRUCTIONS FOR MSM C06

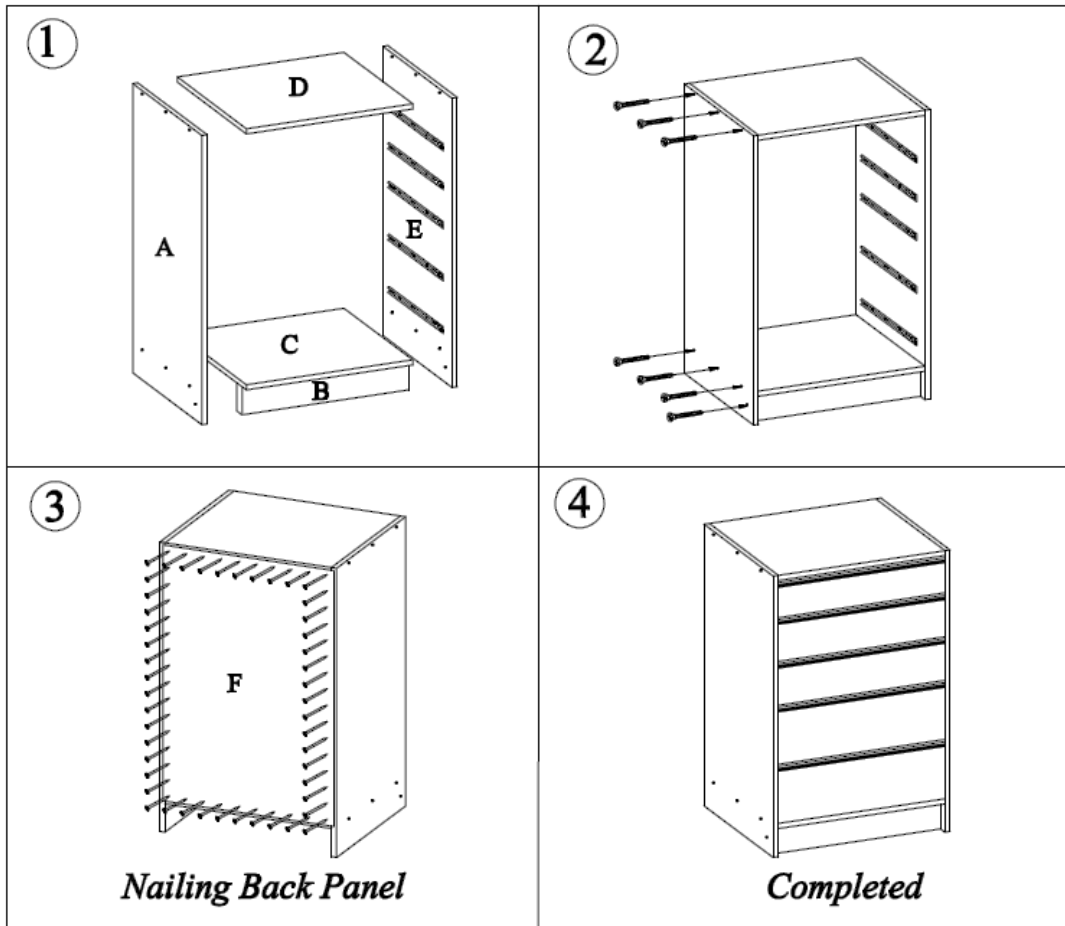

HARDWARE LIST

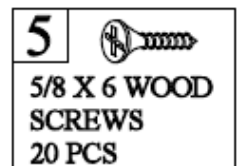
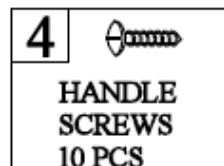
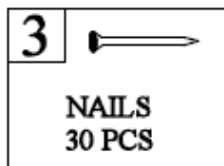
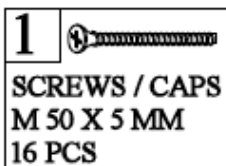

METAL RUNNER POSITIONING FOR MSM C06

CABINET GABLES: (H 1065 X L 500 X D 450 mm)

A = LEFT HAND
E = RIGHT HAND

CABINET RUNNERS:

CL = LEFT HAND
CR = RIGHT HAND

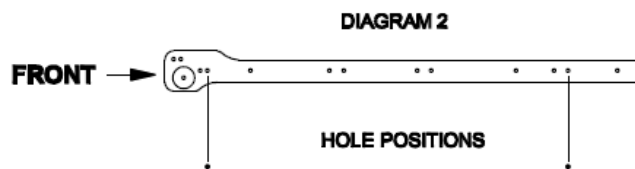

**7.5mm EURO SCREWS TO
ATTACH RUNNERS TO CABINET
GABLES**

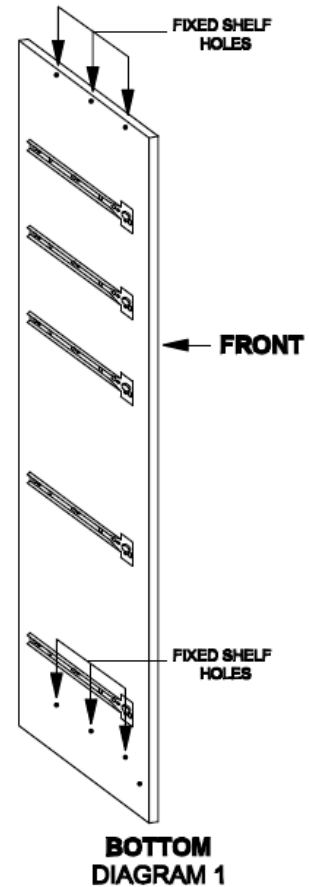

INSTRUCTIONS:

- Lay cabinet gables marked **A & E** on floor and attach the metal cabinet runners to the cabinet gables refer to **Diagram 1**.
- It is important that the runners are fixed to the correct cabinet gables, fix runner marked **CL** to cabinet gable **A** and fix runner marked **CR** to cabinet gable **E** using the special 7.5mm Euro screws provided.
- **Important:** Please note **DIAGRAM 2** this shows the positions of the holes that the metal runners are fixed into.

ASSEMBLY INSTRUCTIONS FOR DRAWER BOX AND METAL RUNNER

STEP 1.

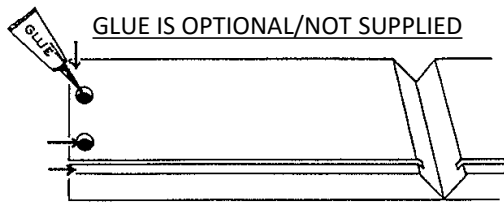

CAREFULLY REMOVE DRAWERS FROM THE CARTON AND LAY FLAT ON THE FLOOR. PLACE A FEW DROPS OF WOOD GLUE (NOT SUPPLIED) IN DOWEL HOLES AND V JOINTS (REFER DIAGRAM)

STEP 2.

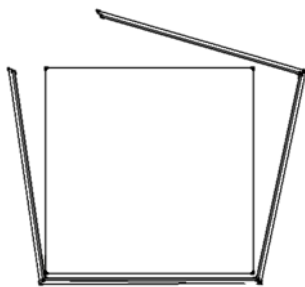

DRAWER BOTTOM

PLACE THE DRAWER BOTTOM INTO GROOVE ON THE DRAWER WITH THE WHITE SIDE TO THE TOP OF THE DRAWER. GENTLY FOLD THE REMAINING SIDES AROUND THE DRAWER BOTTOM UNTIL DOWELS ARE ALIGNED WITH HOLES, PUSH DOWN FIRMLY AND WIPE OFF ANY EXCESS GLUE FROM JOINTS.

STEP 3.

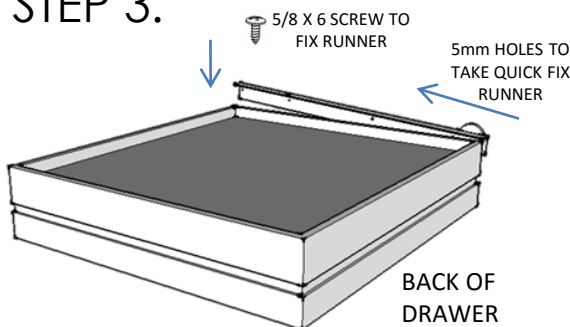

TURN DRAWER BOX UPSIDE DOWN. TAKE RUNNER, INSERT THE TAB INTO 5mm HOLE IN BACK OF DRAWER PUSH FORWARD AND THEN PUSH DOWN SO THE FRONT OF THE TAB WILL ALIGN WITH 5mm HOLES IN THE FRONT OF THE DRAWER ONCE FIRMLY IN PLACE USE 5/8 X 6 SCREWS PROVIDED TO FIX RUNNER.

STEP 4.

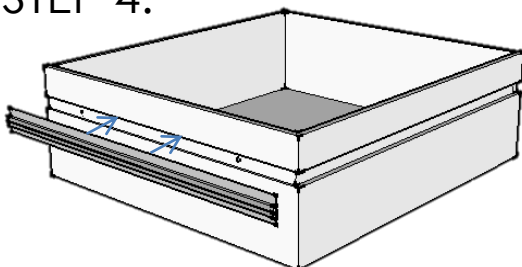

BY USING THE 12mm X 5mm BOLT SUPPLIED INSERT INTO 5mm PRE-DRILLED HOLES IN FRONT OF DRAWER. ALIGN THE ALUMINIUM HANDLE WITH ONE END OF THE DRAWER AND TIGHTEN SCREW. DO THE SAME FOR THE OTHER END. DO NOT OVER TIGHTEN SCREWS.