

21

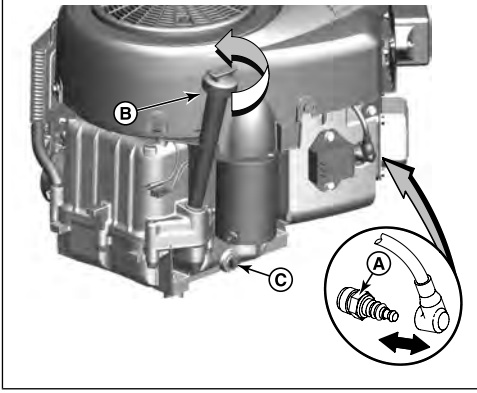

24

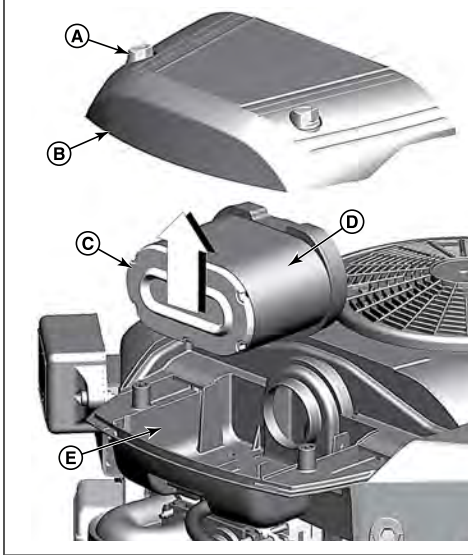

22

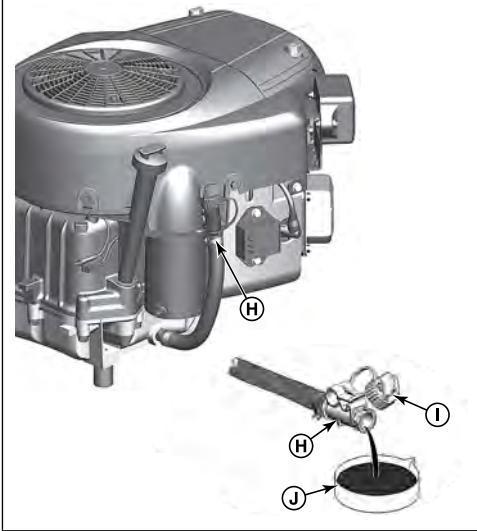

25

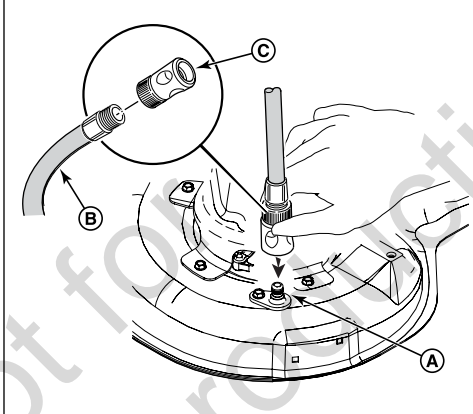

23

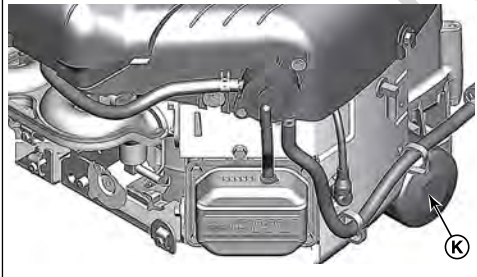

Products Covered by This Manual

The following products are covered by this manual:

2691379-00, 2691380-00, 2691381-00, 2691384-00,
2691385-00, 2691386-00, 2691420-00, 2691420C-00

Manual Contents:

Operator Safety.....	5
Safety Interlock Systems Checks.....	12
Features and Controls.....	12
Operation.....	13
Maintenance.....	17
Troubleshooting.....	20
Specifications.....	21

Save these instructions. This manual contains safety information to make you aware of the hazards and risks associated with the product and how to avoid them. It also contains important instructions that should be followed during the initial set-up, operation, and maintenance of the product.

Save these original instructions for future reference.













Note: For instructions to install, remove, and level the mower deck (including belt replacement), see the Mower Deck Manual supplied with this machine.









Note: The engine information contained in this manual applies to Briggs & Stratton engines only. For information regarding non-Briggs engines, refer to the engine manual supplied with your unit.

The images in this document are representative, and are meant to compliment the instructional copy they accompany. Your unit may vary from the images displayed. *LEFT* and *RIGHT* are as seen from the operator's position.

Operator Safety

Safety Symbols And Meanings

			
Fire	Moving Parts	Shock	Stop
			
Toxic Fumes	Kickback	Explosion	On / Off
			
Wear Eye Protection	Hazardous Chemical	Hot Surface	Choke

			
Read Manual	Fast	Slow	Oil
			
Fuel	Fuel Shut-Off	Roll-Over Hazard	Amputation Hazard

Safety Alert Symbol and Signal Words

The safety alert symbol  is used to identify safety information about hazards that can result in personal injury. A signal word (DANGER, WARNING, or CAUTION) is used with the alert symbol to indicate the likelihood and the potential severity of injury. In addition, a hazard symbol may be used to represent the type of hazard.

 **DANGER** indicates a hazard which, if not avoided, **will result in death or serious injury**.

 **WARNING** indicates a hazard which, if not avoided, **could result in death or serious injury**.

 **CAUTION** indicates a hazard which, if not avoided, **could result in minor or moderate injury**.

NOTICE indicates an situation that **could result in damage to the product**.



U.S.A. Models: The engine exhaust from this product contains chemicals known to the State of California to cause cancer, birth defects, or other reproductive harm.



Battery posts, terminals, and related accessories contain lead and lead compounds, chemicals known to the State of California to cause cancer and birth defects or other reproductive harm. Wash hands after handling.

California Spark Arrester Warning



It is a violation of California Public Resource Code, Section 4442, to use or operate the engine on any forest-covered, brush-covered, or grass-covered land unless the exhaust system is equipped with a spark arrester, as defined in Section 4442, maintained in effective working order. Other states or federal jurisdictions may have similar laws. Contact the original equipment manufacturer, retailer, or dealer to obtain a spark arrester designed for the exhaust system installed on this engine.

Carbon Monoxide Warning



WARNING

POISONOUS GAS HAZARD. Engine exhaust contains carbon monoxide, a poisonous gas that could kill you in minutes. You **CANNOT** see it, smell it, or taste it. Even if you do not smell exhaust fumes, you could still be exposed to carbon monoxide gas. If you start to feel sick, dizzy, or weak while using this product, shut it off and get to fresh air **RIGHT AWAY**. See a doctor. You may have carbon monoxide poisoning.

- Operate this product **ONLY** outside far away from windows, doors and vents to reduce the risk of carbon monoxide gas from accumulating and potentially being drawn towards occupied spaces.
- Install battery-operated carbon monoxide alarms or plug-in carbon monoxide alarms with battery back-up according to the manufacturer's instructions. Smoke alarms cannot detect carbon monoxide gas.
- **DO NOT** run this product inside homes, garages, basements, crawlspaces, sheds, or other partially-enclosed spaces even if using fans or opening doors and windows for ventilation. Carbon monoxide can quickly build up in these spaces and can linger for hours, even after this product has shut off.
- **ALWAYS** place this product downwind and point the engine exhaust away from occupied spaces.

Operating Safety



Power equipment is only as safe as the operator. If it is misused, or not properly maintained, it can be dangerous! Remember, you are responsible for your safety and that of those around you.

Use common sense, and think through what you are doing. If you are not sure that the task you are about to perform can be safely done with the equipment you have chosen, ask a professional: contact your local authorized dealer.

Read the Manual

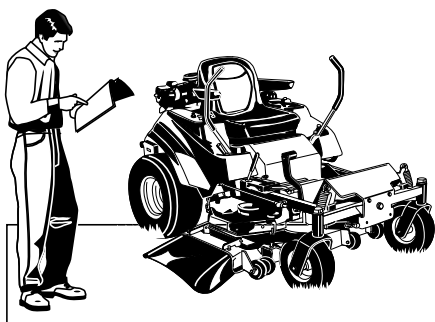

The operator's manual contains important safety information you need to be aware of **BEFORE** you operate your unit as well as **DURING** operation.

Safe operating techniques, an explanation of the product's features and controls, and maintenance information is included to help you get the most out of your equipment investment.

Be sure to completely read the Safety Rules and Information found on the following pages. Also completely read the Operation section.

Children

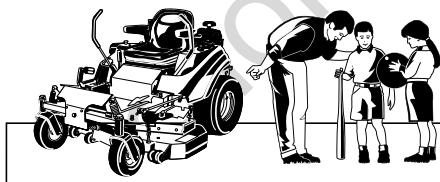

Tragic accidents can occur with children. Do not allow them anywhere near the area of operation. Children are often attracted to the unit and mowing activity. Never assume that children will remain where you last saw them. If there is a risk that children may enter the area where you are mowing, have another responsible adult watch them.

DO NOT GIVE CHILDREN RIDES ON THIS UNIT! This encourages them to come near the unit in the future while it is running, and they could be seriously hurt. They may then approach the unit for a ride when you are not expecting it, and you may run over them.

Reverse

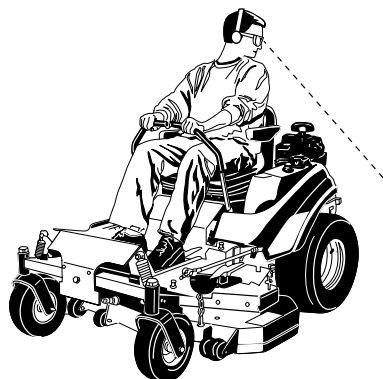

Do not mow in reverse unless absolutely necessary. Always look down and behind before and while traveling in reverse even with the mower blades disengaged.

Slope Operation

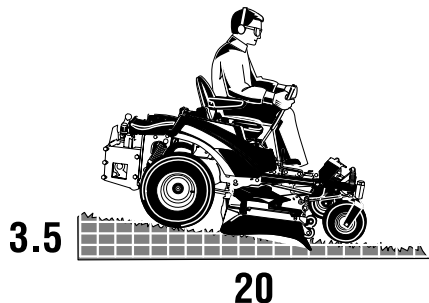

You could be seriously injured or even killed if you use this unit on too steep an incline. Using the unit on a slope that is too steep or where you don't have adequate traction can cause you to lose control or roll over.

A good rule of thumb is to not operate on any slope you cannot back up (in 2-wheel drive mode). You should not operate on inclines with a slope greater than a 3.5 ft (1,1 m) rise over a 20.0 ft (6,0 m) length. Always drive up and down slopes: never cross the face.

Also note that the surface you are driving on can greatly impact stability and control. Wet grass or icy pavement can seriously affect your ability to control the unit.

If you feel unsure about operating the unit on an incline, don't do it. It's not worth the risk.

Moving Parts

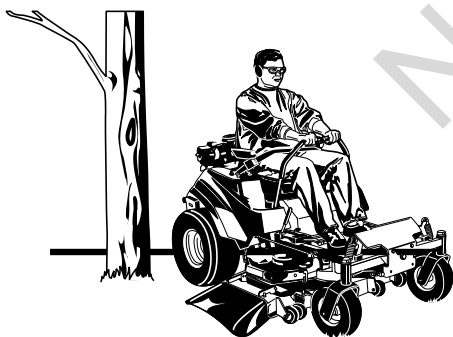

This equipment has many moving parts that can injure you or someone else. However, if you are seated in the seat properly, and follow all the rules in this book, the unit is safe to operate.

The mower deck has spinning mower blades that can amputate hands and feet. Do not allow anyone near the equipment while it is running!

To help you, the operator, use this equipment safely, it is equipped with an operator present safety system. Do NOT attempt to alter or bypass the system. See your dealer immediately if the system does not pass all the safety interlock system tests found in this manual.

Thrown Objects

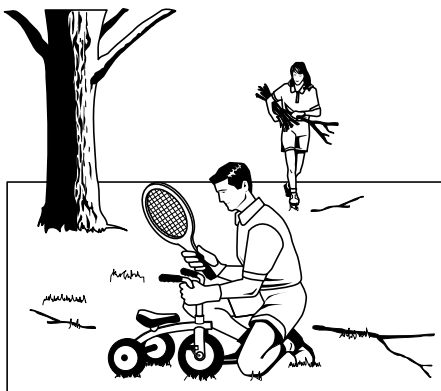

This unit has spinning mower blades. These blades can pick up and throw debris that could seriously injure a bystander. Be sure to clean up the area to be mowed BEFORE you start mowing.

Do not operate this unit without the entire grass catcher or discharge guard (deflector) in place.

Also, do not allow anyone in the area while the unit is running! If someone does enter the area, shut the unit off immediately until they leave.

Fuel and Maintenance

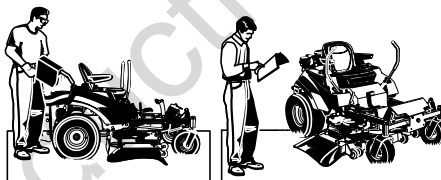

Always disengage all drives, shutoff the engine, and remove the key before doing any cleaning, refueling, or servicing.

Gasoline and its vapors are extremely flammable. Do not smoke while operating or refueling. Do not add fuel while engine is hot or running. Allow engine to cool for at least 3 minutes prior to adding fuel.

Do not add fuel indoors, in an enclosed trailer, garage, or any other enclosed area that is not well ventilated. Gasoline spills should be cleaned up promptly and before operation begins.

Gasoline should be stored only in sealed containers approved for fuel.

Proper maintenance is critical to the safety and performance of your unit. Keep the unit free of grass, leaves, and excess oil. Be sure to perform the maintenance procedures listed in this manual, especially periodically testing the safety system.

Retaining Walls, Drop-Offs, and Water

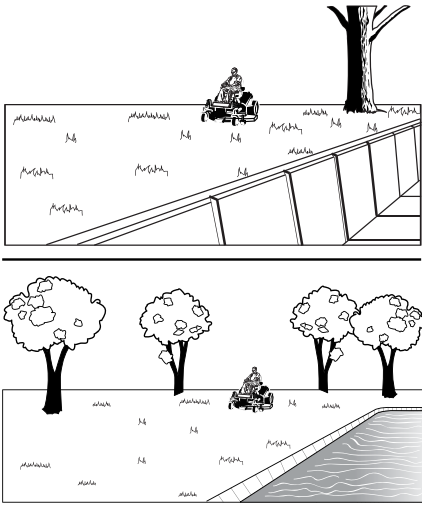

Retaining walls and drop-offs around steps and water are a common hazard. Give yourself a minimum of two mower widths of clearance around these hazards and hand-trim with a walk behind mower or string trimmer. Wheels dropping over retaining walls, edges, ditches, embankments, or into water can cause rollovers, which may result in serious injury, death, or drowning.

General Operating Safety Instructions



WARNING

Read these safety rules and follow them closely. Failure to obey these rules could result in loss of control of unit, severe personal injury or death to you, or bystanders, or damage to property or equipment. **This mowing deck is capable of amputating hands and feet and throwing objects.** The triangle in text signifies important cautions or warnings which must be followed.

General Operation

1. Read, understand, and follow all instructions in the manual and on the unit before starting.
2. Do not put hands or feet near rotating parts or under the machine. Keep clear of the discharge opening at all times.
3. Only allow responsible adults, who are familiar with the instructions, to operate the unit (local regulations can restrict operator age).
4. Clear the area of objects such as rocks, toys, wire, etc., which could be picked up and thrown by the blade(s).
5. Be sure the area is clear of other people before mowing. Stop the unit if anyone enters the area.
6. Never carry passengers.
7. Do not mow in reverse unless absolutely necessary. Always look down and behind before and while traveling in reverse.
8. Never direct discharge material toward anyone. Avoid discharging material against a wall or obstruction. Material may ricochet back toward the operator. Stop the blade(s) when crossing gravel surfaces.
9. Do not operate the machine without the entire grass catcher, discharge guard (deflector), or other safety devices in place.
10. Slow down before turning.
11. Never leave a running unit unattended. Always disengage the PTO, set parking brake, stop engine, and remove keys before dismounting.
12. Disengage blades (PTO) when not mowing. Shut off engine and wait for all parts to come to a complete stop before cleaning the machine, removing the grass catcher, or unclogging the discharge guard.
13. Operate the machine only in daylight or good artificial light.
14. Do not operate the unit while under the influence of alcohol or drugs.
15. Watch for traffic when operating near or crossing roadways.
16. Use extra care when loading or unloading the unit into a trailer or truck.
17. Always wear eye protection when operating this unit.
18. Data indicates that operators, age 60 years and above, are involved in a large percentage of power equipment-related injuries. These operators should evaluate their ability to operate the equipment safely enough to protect themselves and others from injury.
19. Follow the manufacturer's recommendations for wheel weights or counterweights.
20. Keep in mind the operator is responsible for accidents occurring to other people or property.
21. All drivers should seek and obtain professional and practical instruction.
22. Always wear substantial footwear and trousers. Never operate when barefoot or wearing sandals.
23. Before using, always visually check that the blades and blade hardware are present, intact, and secure. Replace worn or damaged parts.
24. Disengage attachments before: refueling, removing an attachment, making adjustments (unless the adjustment can be made from the operator's position).
25. When the machine is parked, stored, or left unattended, lower the cutting means unless a positive mechanical lock is used.
26. Before leaving the operator's position for any reason, disengage the PTO, engage the parking brake (if equipped), stop the engine, and remove the key.
27. To reduce fire hazard, keep the unit free of grass, leaves, & excess oil. Do not stop or park over dry leaves, grass, or combustible materials.
28. It is a violation of California Public Resource Code Section 4442 to use or operate the engine on or near any forest-covered, brush-covered, or grass-covered land unless the exhaust system is equipped with a spark arrester meeting any applicable local or state laws. Other states or federal areas may have similar laws.

Transporting And Storage

1. When transporting the unit on an open trailer, make sure it is facing forward, in the direction of travel. If the unit is facing backwards, wind lift could damage the unit.
2. Always observe safe refueling and fuel handling practices when refueling the unit after transportation or storage.
3. Never store the unit (with fuel) in an enclosed poorly ventilated structure. Fuel vapors can travel to an ignition source (such as a furnace, water heater, etc.) and cause an explosion. Fuel vapor is also toxic to humans and animals.
4. Always follow the engine manual instructions for storage preparations before storing the unit for both short and long term periods.
5. Always follow the engine manual instructions for proper start-up procedures when returning the unit to service.
6. Never store the unit or fuel container inside where there is an open flame or pilot light, such as in a water heater. Allow unit to cool before storing.



WARNING

Unsafe Operation Hazard

Do not load this zero-turn rider on a trailer or truck using two separate ramps. Only use a single ramp that is at least one foot wider than the width of the rear wheels of this rider. This rider has a zero turning radius and the rear wheels could fall off the ramps, or the rider could tip over injuring the operator or bystanders.



Slope Operation

Slopes are a major factor related to loss-of-control and tipover accidents, which can result in severe injury or death. Operation on all slopes requires extra caution. If you feel uneasy on a slope, do not operate on it.

Control of a walk-behind or ride-on machine sliding on a slope will not be regained by the application of the brake. The main reasons for loss of control are: insufficient tire grip on the ground, speed too fast, inadequate braking, the type of machine is unsuitable for its task, lack of awareness of the ground conditions, incorrect hitching and load distribution.

1. Mow up and down slopes, not across.
2. Watch for holes, ruts, or bumps. Uneven terrain could overturn the unit. Tall grass can hide obstacles.

3. Choose a slow speed so that you will not have to stop or change speeds while on the slope.
4. Do not mow on wet grass. Tires may lose traction.
5. Always keep unit in gear especially when traveling down slopes. Do not shift to neutral and coast downhill.
6. Avoid starting, stopping, or turning on a slope. If tires lose traction, disengage the blade(s) and proceed slowly straight down the slope.
7. Keep all movement on slopes slow and gradual. Do not make sudden changes in speed or direction, which could cause the machine to rollover.
8. Use extra care while operating machines with grass catchers or other attachments; they can affect the stability of the unit. Do not use on steep slopes.
9. Do not try to stabilize the machine by putting your foot on the ground (ride-on units).
10. Do not mow near drop-offs, ditches, or embankments. The mower could suddenly turn over if a wheel is over the edge of a cliff or ditch, or if an edge caves in.
11. Do not use grass catchers on steep slopes.
12. Do not mow slopes you cannot back up.
13. See your authorized dealer/retailer for recommendations of wheel weights or counterweights to improve stability.
14. Remove obstacles such as rocks, tree limbs, etc.
15. Use slow speed. Tires may lose traction on slopes even through the brakes are functioning properly.
16. Do not turn on slopes unless necessary, and then, turn slowly and gradually downhill, if possible.



WARNING

Unsafe Operation Hazard

Never operate on slopes greater than 17.6 percent (10°) which is a rise of 3-1/2 feet (106 cm) vertically in 20 feet (607 cm) horizontally.

When operating on slopes use additional wheel weights or counterweights. See your dealer/retailer to determine which weights are available and appropriate for your unit.

Select slow ground speed before driving onto slope. In addition to front weights, use extra caution when operating on slopes with rear-mounted grass catchers.

Mow UP and DOWN the slope, never across the face, use caution when changing directions and DO NOT START OR STOP ON SLOPE.

Towed Equipment (Ride-On Units)

1. Tow only with a machine that has a hitch designed for towing. Do not attach towed equipment except at the hitch point.
2. Follow the manufacturer's recommendations for weight limit for towed equipment and towing on slopes.

- Never allow children or others in or on towed equipment.
- On slopes, the weight of the towed equipment may cause loss of traction and loss of control.
- Travel slowly and allow extra distance to stop.
- Do not shift to neutral and coast down hill.
- Remove gas-powered equipment from the truck or trailer and refuel it on the ground. If this is not possible, then refuel such equipment on a trailer with a portable container, rather than from a gasoline dispenser nozzle.
- Keep nozzle in contact with the rim of the fuel tank or container opening at all times until fueling is complete. Do not use a nozzle lock-open device.
- If fuel is spilled on clothing, change clothing immediately.
- Never over-fill the fuel tank. Replace gas cap and tighten securely.
- Use extra care in handling gasoline and other fuels. They are flammable and vapors are explosive.
- If fuel is spilled, do not attempt to start the engine but move the machine away from the area of spillage and avoid creating any source of ignition until fuel vapors have dissipated.
- Replace all fuel tank caps and fuel container caps securely.

Children

Tragic accidents can occur if the operator is not alert to the presence of children. Children are often attracted to the unit and the mowing activity. Never assume that children will remain where you last saw them.

- Keep children out of the mowing area and under the watchful care of another responsible adult.
- Be alert and turn unit off if children enter the area.
- Before and during reverse operation, look behind and down for small children.
- Never carry children, even with the blade(s) off. They may fall off and be seriously injured or interfere with safe unit operation. Children who have been given rides in the past may suddenly appear in the mowing area for another ride and be run over or backed over by the machine.
- Never allow children to operate the unit.
- Use extra care when approaching blind corners, shrubs, trees, or other objects that may obscure vision.

Emissions

- Engine exhaust from this product contains chemicals known, in certain quantities, to cause cancer, birth defects, or other reproductive harm.
- Look for the relevant Emissions Durability Period and Air Index information on the engine emissions label.

Ignition System

- This spark ignition system complies with Canadian Standard ICES-002.

Service And Maintenance

Safe Handling Of Gasoline

- Extinguish all cigarettes, cigars, pipes, and other sources of ignition.
- Use only approved gasoline containers.
- Never remove the gas cap or add fuel with the engine running. Allow the engine to cool before refueling.
- Never fuel the machine indoors.
- Never store the machine or fuel container where there is an open flame, spark, or pilot light such as near a water heater or other appliance.
- Never fill containers inside a vehicle or on a truck bed with a plastic bed liner. Always place containers on the ground away from your vehicle before filling.

Service & Maintenance

- Never run the unit in an enclosed area where carbon monoxide fumes may collect.
- Keep nuts and bolts, especially blade attachment bolts, tight and keep equipment in good condition.
- Never tamper with safety devices. Check their proper operation regularly and make necessary repairs if they are not functioning properly.
- Keep unit free of grass, leaves, or other debris buildup. Clean up oil or fuel spillage. and remove any fuel-soaked debris. Allow machine to cool before storage.
- If you strike an object, stop and inspect the machine. Repair, if necessary, before restarting.
- Never make adjustments or repairs with the engine running.
- Check grass catcher components and the discharge guard frequently and replace with manufacturer's recommended parts, when necessary.
- Mower blades are sharp. Wrap the blade or wear gloves, and use extra caution when servicing them.
- Check brake operation frequently. Adjust and service as required.
- Maintain or replace safety and instructions labels, as necessary.
- Do not remove the fuel filter when the engine is hot as spilled gasoline may ignite. Do not spread fuel line clamps further than necessary. Ensure clamps grip hoses firmly over the filter after installation.
- Do not use gasoline containing METHANOL, gasohol containing more than 10% ETHANOL, gasoline additives, or white gas because engine/fuel system damage could result.
- If the fuel tank must be drained, it should be drained outdoors.
- Replace faulty silencers/mufflers.

15. Use only factory authorized replacement parts when making repairs.
16. Always comply with factory specifications on all settings and adjustments.
17. Only authorized service locations should be utilized for major service and repair requirements.
18. Never attempt to make major repairs on this unit unless you have been properly trained. Improper service procedures can result in hazardous operation, equipment damage and voiding of manufacturer's warranty.
19. On multiple blade mowers, take care as rotating one blade can cause other blades to rotate.
20. Do not change engine governor settings or over-speed the engine. Operating the engine at excessive speed can increase the hazard of personal injury.
21. Disengage drive attachments, stop the engine, remove the key, and disconnect the spark plug wire(s) before: clearing attachment blockages and chutes, performing service work, striking an object, or if the unit vibrates abnormally. After striking an object, inspect the machine for damage and make repairs before restarting and operating the equipment.
22. Never place hands near the moving parts, such as a hydro pump cooling fan, when the tractor is running. (Hydro pump cooling fans are typically located on top of the transaxle).
23. Units with hydraulic pumps, hoses, or motors: **WARNING:** Hydraulic fluid escaping under pressure may have sufficient force to penetrate skin and cause serious injury. If foreign fluid is injected into the skin it must be surgically removed within a few hours by a doctor familiar with this form of injury or gangrene may result. Keep body and hands away from pin holes or nozzles that eject hydraulic fluid under high pressure. Use paper or cardboard, and not hands, to search for leaks. Make sure all hydraulic fluid connections are tight and all hydraulic hoses and lines are in good condition before applying pressure to the system. If leaks occur, have the unit serviced immediately by your authorized dealer.
24. **WARNING:** Stored energy device. Improper release of springs can result in serious personal injury. Springs should be removed by an authorized technician.
25. Models equipped with an engine radiator: **WARNING:** Stored energy device. To prevent serious bodily injury from hot coolant or steam blow-out, never attempt to remove the radiator cap while the engine is running. Stop the engine and wait until it is cool. Even then, use extreme care when removing the cap.

Safety and Instructional Decals

Before operating your unit, read and understand the safety and instructional decals (compare Figure 1 with the table below).

The cautions, warnings, and instructions are for your safety. To avoid personal injury or damage to the unit, understand and follow all the decals.

If any safety or instructional decals become worn or damaged, and cannot be read, order replacement decals from your dealer.

A	Decal, Tracking Adjustment Part No. 1759724	
B	Decal, Main Safety (ANSI-Export Models) Part No. 1759648	
C	Decal, Cutting Height Part No. 1759253	
D	Decal, Engine Speed (Choke) Part No. 7105770	
D	Decal, Engine Speed (No Choke) Part No. 7105868	
E	Decal, Danger, Thrown Objects (ANSI-Export Models) Part No. 7106109	
F	Decal, Transmission Release Part No. 1758366	
F	Decal, Transmission Release (Suspension Models) Part No. 1758366	

Safety Decal Icon Definitions

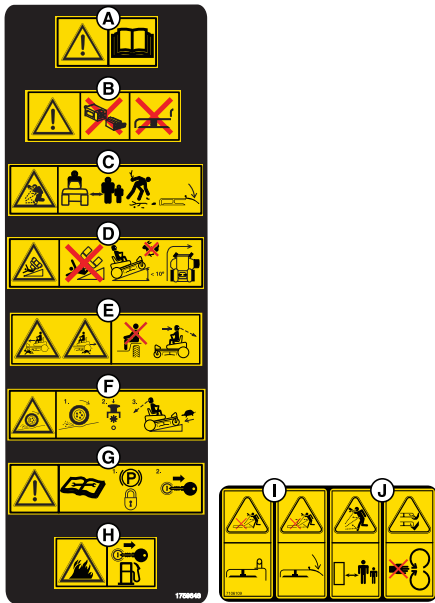

A	WARNING: Read and understand the Operator's Manual before using this machine. Know the location and function of all controls. Do not operate this machine unless you are trained.
B	DANGER - AMPUTATION AND DISMEMBERMENT HAZARD: To avoid injury from rotating blades and moving parts, keep safety devices (guards, shields and switches) in place and working.
C	DANGER - THROWN OBJECTS AND AMPUTATION HAZARD: To avoid injury, keep bystanders and children away. Remove objects that can be thrown by the blades. Do not mow without discharge chute or entire grass catcher in place.
D	DANGER - TIPOVER / ROLLOVER HAZARD: Mow up and down slopes, not across. Do not operate on slopes over 10 degrees. Slow down when turning.
E	DANGER - AMPUTATION HAZARD: Never carry riders, especially children, even with the blades off. Do not mow in reverse unless absolutely necessary. Look down and behind - before and while backing.
F	DANGER - CONTROL HAZARD: If traction is lost on slope, stop forward movement, turn off PTO, and slowly back down slope.
G	DANGER: Engage parking brake, remove key, and consult technical literature before performing service or maintenance.
H	DANGER - FIRE HAZARD: Remove key and wait three (3) minutes before refueling.
I	DANGER - THROWN OBJECTS HAZARD: Do not mow without discharge chute or entire grass catcher in place.
J	DANGER - THROWN OBJECTS AND AMPUTATION HAZARD: To avoid injury from rotating blades, stay clear of deck edge and keep others away.

Safety Interlock Systems Checks



DO NOT operate machine if any safety interlock or safety device is not in place and functioning properly. Contact your dealer immediately for assistance. DO NOT attempt to defeat, modify or remove any safety device.

TEST 1 - Engine must not crank if:

- PTO switch is engaged, OR,
- Ground speed levers are not locked in their START / PARK positions.

TEST 2 - Engine should crank if:

- PTO switch is NOT engaged, AND,
- Ground speed levers are locked in their START / PARK positions.

TEST 3 - Engine must shut off if:

- Operator rises off seat with PTO engaged, OR
- Operator rises off seat with ground speed levers not locked in their START / PARK positions.

TEST 4 - Check mower blade stopping time









The mower blades and mower drive belt should come to a complete stop within five seconds after the electric PTO switch is turned off. If mower drive belt does not stop within five seconds, see your dealer.

Note: Once the engine has stopped, the PTO switch must be turned off and the ground speed levers must be locked in their START/PARK positions in order to start the engine.

Features and Controls

Compare the features and controls in Figure 2 with the table below.

Ref.	Description / Function	Icon(s)	Definition / Operation
A	Deck Lift Pedal, Cutting Height Adjustment Pin and Deck Lift Lock Lever - adjusts cutting height		See Cutting Height Adjustment
B	Right Ground Speed Lever - controls speed and direction of right drive wheel; also engages parking brake		Forward ground speed increase - push lever forward
			Neutral - release lever
			Engine start - move lever out
			Reverse ground speed increase - pull lever back
			Parking brake engage - move lever out
C	Ignition Switch - starts engine		Engine off
			Engine on (run)
			Engine start

D	Engine Speed Control - controls engine speed		Choke on (closed) - Briggs engines only
			Engine speed fast
			Engine speed slow
E	PTO Switch - engages and disengages mower blade clutch		PTO engage - pull up on switch
F	Hour Meter		Indicates total hours of engine operation
G	Transmission Release Levers - release transmissions so unit can roll freely		See <i>Pushing the Unit by Hand</i>
H	Fuel Tank Cap		Turn cap counterclockwise to remove
I	Operator's Seat Adjust		See <i>Seat Adjustments</i>
J	Left Ground Speed Lever - controls speed and direction of left drive wheel		Forward ground speed increase - push lever forward
			Neutral - release lever
			Engine start - move lever out
			Reverse ground speed increase - pull lever back

B	10W-30 - Above 80 °F (27 °C) the use of 10W-30 may cause increased oil consumption. Check oil level more frequently.
C	Synthetic 5W-30
D	5W-30

Check Oil Level

See Figure: 3

Before adding or checking the oil

- Make sure the engine is level.
- Clean the oil fill area of any debris.

1. Remove the dipstick (A, Figure 3) and wipe with a clean cloth.
2. Install and tighten the dipstick (A, Figure 3).
3. Remove the dipstick and check the oil level. Correct oil level is at the top of the full indicator (B, Figure 3) on the dipstick.
4. If oil level is low, slowly add oil into the engine oil fill (C, Figure 3). **Do not overfill.** After adding oil, wait one minute and then recheck the oil level.

Note: Do not add oil at the quick oil drain, if equipped. For location, see *Features and Controls*.

5. Reinstall and tighten the dipstick (A, Figure 3).

Oil Pressure

If the oil pressure is too low, a pressure switch (if equipped) will either stop the engine or activate a warning device on the equipment. If this occurs, stop the engine and check the oil level with the dipstick.

If the oil level is below the ADD mark, add oil until it reaches the FULL mark. Start the engine and check for proper pressure before continuing to operate.

If the oil level is between the ADD and FULL marks, **do not start the engine.** Contact an authorized dealer to have the oil pressure problem corrected.

Fuel Recommendations

Fuel must meet these requirements:

- Clean, fresh, unleaded gasoline.
- A minimum of 87 octane / 87 AKI (91 RON). For high altitude use, see below.
- Gasoline with up to 10% ethanol (gasohol) is acceptable.

NOTICE Do not use unapproved gasolines, such as E15 and E85. Do not mix oil in gasoline or modify the engine to run on alternate fuels. Use of unapproved fuels will cause damage to engine components, **which will not be covered under warranty.**

To protect the fuel system from gum formation, mix a fuel stabilizer into the fuel. See **Storage**. All fuel is not the same. If starting or performance problems occur, change fuel providers or change brands. This engine is certified to operate on gasoline.

Operation

Oil Recommendations

Oil Capacity: See the *Specifications* section.

We recommend the use of Briggs & Stratton Warranty Certified oils for best performance. Other high-quality detergent oils are acceptable if classified for service SF, SG, SH, SJ or higher. Do not use special additives.

Outdoor temperatures determine the proper oil viscosity for the engine. Use the chart to select the best viscosity for the outdoor temperature range expected.

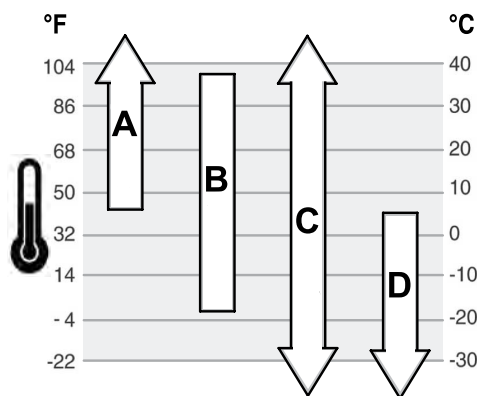

A	SAE 30 - Below 40 °F (4 °C) the use of SAE 30 will result in hard starting.
---	--

The emissions control system for this engine is EM (Engine Modifications).

High Altitude

At altitudes over 5,000 feet (1524 meters), a minimum 85 octane/85 AKI (89 RON) gasoline is acceptable.

For carbureted engines, high altitude adjustment is required to maintain performance. Operation without this adjustment will cause decreased performance, increased fuel consumption, and increased emissions. Contact a Briggs & Stratton Authorized Service Dealer for high altitude adjustment information. Operation of the engine at altitudes below 2,500 feet (762 meters) with the high altitude adjustment is not recommended.

For Electronic Fuel Injection (EFI) engines, no high altitude adjustment is necessary.

Adding Fuel



Fuel and its vapors are extremely flammable and explosive.

Fire or explosion can cause severe burns or death.

When Adding Fuel

- Turn engine off and let engine cool at least 3 minutes before removing the fuel cap.
 - Fill fuel tank outdoors or in well-ventilated area.
 - Do not overfill fuel tank. To allow for expansion of the fuel, do not fill above the bottom of the fuel tank neck.
 - Keep fuel away from sparks, open flames, pilot lights, heat, and other ignition sources.
 - Check fuel lines, tank, cap, and fittings frequently for cracks or leaks. Replace if necessary.
 - If fuel spills, wait until it evaporates before starting engine.
1. Clean the fuel cap area of dirt and debris. Remove the fuel cap (A, Figure 4).
 2. Fill the fuel tank with fuel. To allow for expansion of the fuel, do not fill above the bottom of the fuel tank neck (B).
 3. Reinstall the fuel cap.

Starting the Engine



- If you do not understand how a specific control functions, or have not yet thoroughly read the *Features & Controls* section, do so now.
- Do NOT attempt to operate the tractor without first becoming familiar with the location and function of all controls.

1. While sitting in the operator's seat, make sure the PTO switch is disengaged and the ground speed control levers are locked in the START/PARK position.

Note: The parking brake is automatically engaged when the ground speed levers are locked in the START/PARK position.

2. Set the engine speed control past the FAST position to the CHOKE position.

Note: A warm engine does not require choking.

Note: Some engines are equipped with a separate choke control.

Note: Some engines are equipped with a ReadyStart® feature, and do not feature a choke.

3. Insert the key into the ignition switch and turn it to START.
4. After the engine starts, turn off the choke (if equipped), and warm up the engine by running it for at least a minute before engaging the PTO switch or driving the rider.
5. After warming the engine, always operate the unit at full engine speed when mowing.

In the event of an emergency the engine can be stopped by simply turning the ignition switch to STOP. Use this method only in emergency situations. For normal engine shut down follow the procedure given in ***Stopping The Rider And Engine.***

Stopping the Rider

1. Return the ground speed levers to the middle (or *neutral* 'N') position to stop rider movement. Pivot the levers outward to lock them in the START/PARK position.

Note: Moving the ground speed levers to the START/ PARK position automatically engages the parking brake.

2. Disengage the PTO by pushing down on the PTO switch.
3. Move the engine speed control to the SLOW position and turn the ignition switch to OFF. Remove the key.

Mowing

1. Make sure the PTO switch is disengaged, the ground speed control levers are locked in their START/PARK positions, and the operator is in the seat.
2. Start the engine. See ***Starting the Engine.***
3. Set the mower cutting height. See ***Cutting Height Adjustment.***
4. Set the engine speed control to FAST.
5. Engage the PTO by pulling up on the PTO switch.
6. Pivot the ground speed levers in from the START/PARK position to the neutral 'N' position.
7. Begin mowing. See ***Operator Safety*** for tips on safe mowing practices.
8. When finished, shut off the PTO.

9. Stop the engine. See *Stopping The Rider And Engine*.

Pushing the Rider By Hand



WARNING

Unsafe Operation Hazard.

DO NOT disengage the transmissions and coast down slopes. DO NOT use Roll Release to disengage the transmissions unless machine motion can be controlled and engine is off.

NOTICE

Do not tow rider. Towing the unit will cause transmission damage. Do not use another vehicle to push or pull this unit.

1. Disengage the PTO, lock the ground speed levers into their START/PARK positions, turn the ignition OFF, remove the key, and wait for all moving parts to stop.
2. To disengage the transmissions, move the roll release levers (A or B, Figure 5, depending on model), into the PUSH position as shown.
3. Pivot the ground speed levers in from the START/ PARK position to the neutral 'N' position to disengage the parking brake. The rider can now be pushed by hand.
4. After moving the rider, re-engage the transmissions by moving the roll release levers back to the DRIVE position.

Driving

Zero Turn Driving Practice

Before attempting to drive the zero-turn riding mower make sure you have read the *Features and Controls* section and understand the location and function of all of the unit's controls.

The ground speed control levers of this zero-turn riding mower are responsive, and learning to gain a smooth and efficient control of the unit's forward, reverse, and turning movements will take some practice.

Spending some time going through the maneuvers shown and becoming familiar with how the unit accelerates, travels, and steers, **before you begin mowing**, is absolutely essential to getting the most out of the zero-turn riding mower.

Locate a smooth, flat area of your lawn, one with plenty of room to maneuver. Clear the area of objects, people, and animals before you begin. Operate the unit at mid-throttle during this practice session (ALWAYS operate at full throttle when mowing), and turn slowly to prevent tire slippage and damage to your lawn.

We suggest you begin with the *Smooth Travel* procedure, and then advance through the forward, reverse, and turning maneuvers.

Smooth Travel

The lever controls of the Zero Turn rider are responsive.

The BEST method of handling the ground speed control levers is in three steps — as shown in Figure 6.

FIRST place your hands onto the levers as shown.

SECOND, to go forward gradually push the levers forward with your palms.

THIRD, to speed up move the levers farther forward. To slow down smoothly, slowly move the levers toward neutral.

Basic Driving

Forward Travel Practice

Gradually move both ground speed control levers — evenly FORWARD from neutral. Slow down and repeat.

NOTE: Straight forward travel takes practice. If necessary, top speed can be balance-adjusted — see the Speed Balancing Adjustment in the Adjustments section near the back of this manual.

Reverse Travel Practice

LOOK DOWN & BEHIND, then gradually move both ground speed control levers evenly BACK from neutral. Slow down and repeat.

NOTE: Practice backing up for several minutes before attempting to do so near objects. The rider turns sharply in reverse as well as forward, and backing up straight takes practice.

Practice Turning Around A Corner

While traveling forward allow one handle to gradually return back toward neutral. Repeat several times.

NOTE: To prevent pivoting directly on the tire tread, it is best to keep both wheels going at least slightly forward.

Practice Turning in Place

To turn in place, "Zero Turn," gradually move one ground speed control lever forward from neutral and one lever back from neutral simultaneously. Repeat several times.

NOTE: Changing the amount each lever is pulled—forward or back, changes the "pivot point" you turn on.

Advanced Driving

Executing an End-Of-Row Zero Turn

Your Zero Turn Rider's unique ability to turn in place allows you to turn around at the end of a cutting row rather than having to stop and Y-turn before starting a new row.

For example, to execute a left end-of row zero turn:

1. Slow down at the end of the row.
2. Move the RIGHT ground speed control lever forward slightly while moving the LEFT ground speed control lever back to center and then slightly back from center.
3. Begin mowing forward again.

This technique turns the rider LEFT and slightly overlaps the row just cut —eliminating the need to back up and re-cut missed grass.

As you become more familiar and experienced with operating the Zero Turn rider, you will learn more maneuvers that will make your mowing time easier and more enjoyable.

Remember, the more you practice, the better your control of the Zero Turn will be!

Attaching a Trailer

Secure the trailer with an appropriately sized clevis pin (A, Figure 12) and clip (B). See **Operator Safety** for additional safety information regarding trailers and towing.



WARNING

Towing Hazard

Towed loads can be hazardous and cause loss of control on slopes.

- The max gross (trailer & load) weight of trailer is 200 lbs (91kg).
- Do not operate on slope exceeding 5 degrees.
- Reduce speed and use extreme caution on slopes.

Cutting Height Adjustment

The cutting height adjust pedal adjusts the mower cutting height. See **Specifications** for cutting height adjustment range.

To adjust cutting height:

1. Fully depress the cutting height adjust pedal (A, Figure 13) until the transport release rod (B) locks the deck into the highest position (transport position).
2. Remove the pin (C, Figure 13) from the adjustment bracket, and insert it in the desired hole.

Note: Make sure the pin is inserted into the holes in both upper and lower plates of the adjustment bracket.

3. Depress the cutting height adjust pedal, move the transport release rod outward, and slowly release the pedal until it rests against the pin.

Mower Removal And Installation

Refer to the Mower Deck Manual for instructions on removing and installing the mower deck.

Mower Deck Leveling

Refer to the Mower Deck Manual for instructions on leveling the mower deck.

Cargo Bed (select models)

The cargo bed is designed to carry up to 50 lbs (22,7 kg). Slots in the rear of the bed will accommodate a 2 x 4 or 2 x 6 to help secure loads during transport.



WARNING

Amputation Hazard

Rotating blades cut off arms and legs. Do not carry riders (especially children) even with the blades off. They may fall off or return for another ride when you are not expecting it.



WARNING

Loss of Control and Roll-Over Hazard

Operating with loads in the cargo bed greater than 50 lbs can be hazardous and cause loss of control and roll-overs.

The cargo bed can be raised to access the engine compartment without removing it.

To raise the cargo bed

1. Raise the seat (A, Figure 14).
2. Pull up firmly on the rear of the bed (B, Figure 14).
3. When lowering the bed, press down firmly to secure the rear of the bed in place with the locking clips (D).

To remove the cargo bed

1. Remove the pins (C, Figure 14) securing the front of the bed to the rider frame.
2. Pull up firmly on the rear of the bed to release the locking clips (D, Figure 14).
3. Lift and remove the cargo bed from the rider.



CAUTION

To avoid injury, assistance is required when removing or installing the cargo bed.

To install the cargo bed

1. Position the bed over the engine compartment, aligning the holes in the front of the bed with the holes in the frame brackets.
2. Install the pins (C, Figure 14) into the holes.
3. Lower the rear of the bed, pressing down firmly to secure with the locking clips (D, Figure 14).



CAUTION

To avoid injury, assistance is required when removing or installing the cargo bed.

Suspension Adjustment (if equipped)

The shock assemblies (A, Figure 15 - front shown, rear similar) can be adjusted to vary the amount of pre-load applied to the springs. This allows the operator to customize the ride according to operator's weight and operating conditions.

Less Pre-Load:

- Light operator weight
- Softer, more cushioned ride
- Best for relatively flat terrain

More Pre-Load:

- Heavy operator weight
- Stiffer, more rigid ride
- Better handling and greater stability on hilly terrain

To Adjust the Spring Pre-Load:

1. Park machine on a flat, level surface. Disengage the PTO, pivot the ground speed levers out to the START/ PARK position, and stop the engine.
2. Turn the pre-load adjustment collar (B, Figure 15) to a higher notch (-) to decrease the pre-load, or to a lower notch (+) to increase the pre-load. Make sure all shocks are set to the same amount of pre-load.

Maintenance

Maintenance Schedule



WARNING

Unintentional sparking can result in fire or electric shock.

Unintentional start-up can result in entanglement, traumatic amputation, or laceration.

Before performing adjustments or repairs:

- Disconnect the spark plug wire and keep it away from the spark plug.
- Disconnect battery at negative terminal (only engines with electric start).
- Use only correct tools.
- Do not tamper with governor spring, links, or other parts to increase engine speed.
- Replacement parts must be of the same design and installed in the same position as the original parts. Other parts may not perform as well, may damage the unit, and may result in injury.
- Do not strike the flywheel with a hammer or hard object because the flywheel may shatter during operation.

TRACTOR AND MOWER
Every 8 Hours or Daily
Check safety interlock system
Clean debris off tractor and mower deck
Clean debris from engine compartment
Every 25 Hours or Annually *
Check mower blade stopping time
Check tractor and mower for loose hardware
Check tire pressure
Every 50 Hours or Annually *

TRACTOR AND MOWER
Check tractor brakes
Clean battery and cables
See Dealer Annually to
Lubricate tractor and mower
Check mower blades **

* Whichever comes first

** Check blades more often in regions with sandy soils or high dust conditions.

ENGINE
First 5 Hours
Change engine oil
Every 8 Hours or Daily
Check engine oil level
Every 25 Hours or Annually *
Clean engine air filter and pre-cleaner **
Every 50 Hours or Annually *
Change engine oil
Replace oil filter
Annually
Replace air filter
Replace pre-cleaner
See Dealer Annually to
Inspect muffler and spark arrester
Replace spark plug
Replace fuel filter
Clean engine air cooling system

* Whichever comes first

** Clean more often in dusty conditions or when airborne debris is present.

Emissions Control Service

Maintenance, replacement, or repair of the emissions control devices and systems may be performed by any off-road engine repair establishment or individual. However, to obtain "no charge" emissions control service, the work must be performed by a factory authorized dealer. See the Emissions Control Statements.

Checking Tire Pressures

Tire pressure should be checked periodically (see Figure 16), and maintained at the levels shown in the **Specifications** chart. Note that these pressures may differ slightly from the "Max Inflation" stamped on the side-wall of the tires. The pressures shown provide proper traction and extend tire life.

Check Mower Blade Stopping Time

Mower blades and mower drive belt should come to a complete stop within five seconds after the electric PTO switch is turned off.



WARNING

Unsafe Operation Hazard

If the mower blade does not come to a complete stop within 5 seconds, the blade must be adjusted. Do not operate the machine until the proper adjustment has been performed by an authorized dealer.

Check the mower blade for proper function. See Safety Interlock System Tests. The blade should stop rotating in 5 seconds or less after moving the blade control to the OFF position.

Battery Maintenance



WARNING

Explosion and Fire Hazard

When removing or installing battery cables, disconnect the negative cable FIRST and reconnect it LAST. If not done in this order, the positive terminal can be shorted to the frame by a tool.

Cleaning the Battery and Cables

1. Disconnect the cables from the battery, negative cable first (B, Figure 17).
2. Clean the battery terminals and cable ends with a wire brush until shiny.
3. Reinstall the battery and reattach the battery cables, positive cable first (A, Figure 17).
4. Coat the cable ends and battery terminals with petroleum jelly or non-conducting grease.
5. Be sure to replace the terminal cover over the positive battery terminal (A, Figure 17).

Charging The Battery



WARNING

Explosion and Fire Hazard

Keep open flames and sparks away from the battery; the gasses coming from it are highly explosive. Ventilate the battery well during charging.

A dead battery or one too weak to start the engine may be the result of a defect in the charging system or other electrical component. If there is any doubt about the cause of the problem, see your dealer.

To charge the battery, follow the instructions provided by the battery charger manufacturer as well as all warnings included in the **Operator Safety** section of this manual. Charge the battery until fully charged. Do not charge at a rate higher than 10 amps.

Seat And Ground Speed Lever Adjustments

The seat and ground speed levers should be adjusted so that the ground speed levers can be moved through their full range of motion without contacting the operator's legs.

Seat Adjustment

1. Raise the seat.
2. Loosen the adjustment hardware (A or B, Figure 18, depending on seat type) under the seat base.
3. Slide the seat forward or backward to the desired position.
4. Tighten the hardware to 80 lb-in (9 Nm).

Ground Speed Lever Adjustment

1. Loosen the ground speed lever mounting hardware (A, Figure 19) to adjust the levers forward and backward.
2. Remove the hardware to raise or lower the levers.
3. Always be sure to adjust both levers so that they are aligned (B, Figure 19).
4. After adjustment is complete, tighten the hardware to 13 lb-ft (18 Nm).

Speed Balancing (Tracking) Adjustment

If the rider drifts to the right or left when the ground speed levers are in the maximum forward position, the top speed of each of these levers can be balanced. Only adjust the speed of the wheel that is traveling faster.

1. Tighten the knob (A, Figure 20) of the faster wheel by 1/2-turn (clockwise) increments until the rider travels (tracks) straight.



WARNING

Unsafe Operation Hazard

DO NOT adjust the rider for a faster overall speed forward or reverse than it was designed.

Changing The Oil

Used oil is a hazardous waste product and must be disposed of properly. Do not discard with household waste. Check with your local authorities, service center, or dealer for safe disposal/recycling facilities.

Draining The Oil

1. With engine off but still warm, disconnect the spark plug wire (A, Figure 21) and keep it away from the spark plug.
2. Remove the dipstick (B, Figure 21).

Standard Oil Drain Plug

1. Remove the oil drain plug (C, Figure 21). Drain the oil into an approved container.

2. After the oil has drained, install and tighten the oil drain plug.

Optional Quick Oil Drain

1. Disconnect the oil drain hose (H, Figure 22) from the side of the engine.
2. Turn and remove the oil drain cap (I, Figure 22). Carefully lower the quick oil drain (H) into an approved container (J).
3. After the oil has drained, install the oil drain cap. Attach the oil drain hose to the side of the engine.

Changing The Oil Filter

For replacement intervals, see **Maintenance Schedule**.

1. Drain the oil from the engine. See **Draining The Oil**.
2. Remove the oil filter (K, Figure 23) and dispose of properly.
3. Before installing the new oil filter, lightly lubricate the oil filter gasket with fresh, clean oil.
4. Install the oil filter by hand until the gasket contacts the oil filter adapter, then tighten the oil filter 1/2 to 3/4 turns.
5. Add oil. See **Operation - Check Oil Level**.
6. Start and run the engine. As the engine warms up, check for oil leaks.
7. Stop the engine and check the oil level.

Servicing The Air Filter



Fire and Explosion Hazard

Fuel and its vapors are extremely flammable and explosive.

Fire or explosion can cause severe burns or death.

- Never start or run the engine with the air cleaner assembly or air filter removed.

NOTICE

Do not use pressurized air or solvents to clean the filter. Pressurized air can damage the filter and solvents will dissolve the filter.

1. Loosen the fasteners (A, Figure 24) and remove the cover (B).
2. To remove the filter (C, Figure 24), lift the end of the filter.
3. Remove the pre-cleaner (D, Figure 24), if equipped, from the filter.
4. To loosen debris, gently tap the filter on a hard surface. If the filter is excessively dirty, replace with a new filter.
5. Wash the pre-cleaner in liquid detergent and water. Then allow it to thoroughly air dry. Do not oil the pre-cleaner.
6. Assemble the dry pre-cleaner to the filter.
7. Install the filter into the engine base (E, Figure 24) and push down until the filter snaps in place.
8. Install the cover.

Cleaning

1. Clean dirt and debris from the rider and mower deck.
Note: Some mower decks feature a washout port. See **Washing The Mower Deck**.
2. Clean any debris buildup in the engine compartment and from on or around the engine.



Fire Hazard

Yard debris is combustible.

- Clean dirt and debris from the rider and mower deck.
- Clean build-up from around the engine.

Washing The Mower Deck

The washout port allows you to connect a typical garden hose to the left-hand side of the mower deck to remove grass and debris from the underside.



Amputation and Thrown Object Hazard

Contact with the mower blades, or with objects thrown by the mower blades, could result in death or serious injury.

- Before running the mower, make sure the hose is properly connected and does not come into contact with the blades.
- When the mower is running and the blades are engaged, the person cleaning the mower deck must be in the operator position, with no bystanders in the area.

1. Place the unit on a smooth level surface.
2. Attach the quick disconnect (A, Figure 25) to garden hose (B) and connect to the washout port (C) on the mower deck.
3. Run water to remove grass and debris from the underside of the mower deck.
4. Turn the mower on and place in the highest cutting position.
5. Turn the mower off.
6. Remove the garden hose and quick disconnect from the washout port when completed.

Storage



Fire and Explosion Hazard

Never store the unit (with fuel) in an enclosed, unventilated structure. Fuel vapors can travel to an ignition source (such as a furnace, water heater, etc.) and cause an explosion. Fuel vapor is also toxic to humans and animals.

When Storing Fuel Or Equipment With Fuel in Tank

- Store away from furnaces, stoves, water heaters, or other appliances that have pilot lights or other ignition sources because they can ignite fuel vapors.

Equipment

Disengage the PTO, lock the ground speed levers in the START/PARK position, and remove the key.

Battery life will be increased if it is removed. Put in a cool, dry place and keep fully charged during storage. If the battery is left in the unit, disconnect the negative cable.

Fuel System

Fuel can become stale when stored over 30 days. Stale fuel causes acid and gum deposits to form in the fuel system or on essential carburetor parts. To keep fuel fresh, use **Briggs & Stratton® Advanced Formula Fuel Treatment & Stabilizer**, available wherever Briggs & Stratton genuine service parts are sold.

There is no need to drain gasoline from the engine if a fuel stabilizer is added according to instructions. Run the engine for 2 minutes to circulate the stabilizer throughout the fuel system. The engine and fuel can then be stored up to 24 months.

If gasoline in the tank has not been treated with a fuel stabilizer, it must be drained into an approved container. Run the engine until it stops from lack of fuel. The use of a fuel stabilizer in the storage container is recommended to maintain freshness.

Engine Oil

While the engine is still warm, change the engine oil.

Before starting the unit after it has been stored:

- Check all fluid levels. Check all maintenance items.
- Perform all recommended checks and procedures found in this manual.
- Allow the engine to warm up for several minutes before use.

Troubleshooting

Troubleshooting The Rider

PROBLEM	LOOK FOR	REMEDY
Engine will not turnover or start.	Ground speed levers not in START/PARK positions.	Lock ground speed levers in START/ PARK positions.
	PTO (electric clutch) switch in ON position.	Place in OFF position.
	Out of fuel.	If engine is hot, allow it to cool, then refill the fuel tank.
	Fuel valve closed (if equipped).	Open fuel valve.
	Engine flooded.	Open the choke (if equipped).
	Gas is old or stale.	Drain fuel and replace with fresh fuel.
	Battery terminals require cleaning.	Clean the battery terminals.
	Battery discharged or dead.	Recharge or replace.
	Spark plug(s) faulty, fouled or incorrectly gapped.	Clean and gap or replace.
	Water in fuel.	Drain fuel and refill with fresh fuel.
Engine starts hard or runs poorly.	Fuel mixture too rich.	Clean air filter. Check the choke (if equipped).
	Spark plug faulty, fouled, or incorrectly gapped.	Clean and gap or replace.
	Fuel filter dirty.	Replace fuel filter.
Engine knocks.	Low oil level.	Check/add oil as required.
	Using wrong grade oil.	See Oil Recommendations .
Excessive oil consumption.	Engine running too hot.	Check engine fins, blower screen, and air cleaner.
	Using wrong grade oil.	See Oil Recommendations .
	Too much oil in crankcase.	Drain excess oil.
Engine exhaust is black.	Dirty air filter.	Replace air filter.
	Engine choke control is in closed position.	Open choke control (if equipped).
Engine runs, but rider will not drive.	Transmission(s) disengaged.	Unlock roll release lever(s).
Rider drive belt slips.	Pulleys or belt greasy or oily.	Clean as required.
Rider steers or handles poorly.	Steering linkage is loose.	Check and tighten any loose connections.

For all other issues, see authorized dealer.

Troubleshooting The Mower

PROBLEM	LOOK FOR	REMEDY
Mower will not raise.	Mower deck not properly installed.	See Mower Removal And Installation .

PROBLEM	LOOK FOR	REMEDY
Mower cut is uneven.	Mower not leveled properly.	See Mower Deck Leveling .
	Rider tires not inflated equally or properly.	See Maintenance section.
Mower cut is rough looking.	Engine speed too slow.	See engine speed control to FAST.
	Ground speed too fast.	Decrease ground speed.
Engine stalls easily with mower engaged.	Engine speed too slow.	Set engine speed control to FAST.
	Ground speed too fast.	Decrease ground speed.
	Cutting height set too low.	Cut tall grass at maximum cutting height during first pass.
	Discharge chute jamming with cut grass.	Cut grass with discharge pointing toward previously cut area.
Excessive mower vibration.	Blade mounting hardware is loose.	Tighten to 50-60 ft-lbs (68-81 Nm).

For all other issues, see authorized dealer.

Specifications

ENGINE

Briggs & Stratton

Intek™ Series	
Displacement	44.18 cu in. (724 cc)

Power Ratings

The gross power rating for individual gasoline engine models is labeled in accordance with SAE (Society of Automotive Engineers) code J1940 Small Engine Power & Torque Rating Procedure, and is rated in accordance with SAE J1995. Torque values are derived at 2600 RPM for those engines with “rpm” called out on the label and 3060 RPM for all others; horsepower values are derived at 3600 RPM. The gross power curves can be viewed at www.BRIGGSandSTRATTON.COM. Net power values are taken with exhaust and air cleaner installed whereas gross power values are collected without these attachments. Actual gross engine power will be higher than net engine power and is affected by, among other things, ambient operating conditions and engine-to-engine variability. Given the wide array of products on which engines are placed, the gasoline engine may not develop the rated gross power when used in a given piece of power equipment. This difference is due to a variety of factors including, but not limited to, the variety of engine components (air cleaner, exhaust, charging, cooling, carburetor, fuel pump, etc.), application limitations, ambient operating conditions (temperature, humidity, altitude), and engine-to-engine variability. Due to manufacturing and capacity limitations, Briggs & Stratton may substitute an engine of higher rated power for this engine.

Note: The engine information contained in this manual applies to Briggs & Stratton engines only. For information regarding non-Briggs engines, refer to the engine manual supplied with your unit.

Parts And Accessories

See an Authorized Service Dealer.

Professional Series™	
Displacement	44.18 cu in. (724 cc)
All Engines	
Oil Capacity	64 oz (1,9 L)
Spark Plug Gap	0.030 in. (0,76 mm)
Spark Plug Torque	180 in-lbs (20 Nm)

CHASSIS

Fuel Tank Capacity	3 gal (11,4 L)
Inflation Pressure	
- Front Wheels	22 psi (1,52 bar)
- Rear Wheels	12 psi (0,83 bar)

TRANSMISSION

Type	Hydro-Gear® EZT® Hydro-Gear® ZT-2800®
------	--

MOWER

Width of Cut	42" (107 cm)
	44" (112 cm)
	46" (117 cm)
	48" (122 cm)
	52" (132 cm)
Cutting Height	1.5" - 3.75" (3,8 - 9,5 cm)
	1.5" - 4.5" (3,8 - 11,7 cm)

Not for
Reproduction

Not for
Reproduction

Not for
Reproduction