

VISIT: tuffbounce.com.au



OR FOR PARTS OR GENERAL ENQUIRIES: info@tuffbounce.com.au





TRAMPOLINE

10 FOOT

- Safe Spring Bounce System
- Certified to Australian Standard (AS 4989 - 2015)
- 150kg Rated
- High and Durable Safety Net
- Fun for the Whole Family



 **WARNING** 

	<p>SOMERSAULTS OR FLIPS CAN CAUSE SERIOUS INJURY, PARALYSIS OR DEATH</p>	
	<p>ENSURE THE FRAME PADS AND ENCLOSURE SYSTEM ARE ATTACHED AND IN GOOD CONDITION BEFORE USE</p>	
	<p>NO MORE THAN ONE PERSON AT A TIME</p> <p>MAXIMUM USER WEIGHT '150KG'</p> <p>USE TRAMPOLINE UNDER ADULT SUPERVISION</p>	



SAFETY INFORMATION

MUST READ BEFORE USE

**THE FOLLOWING SAFETY STEPS MUST BE APPLIED
WHEN USING THIS PRODUCT.
IMPROPER USE COULD LEAD TO SERIOUS INJURY OR DEATH.**

1. - Two people are required in order to assemble this product. Assembly can take two hours to fully complete.
2. - Never use this product if the assembly process has not been completed as per the instructions in this user guide.
3. - Springs and moving parts during assembly are treated as parts under pressure. Children should be at least 5m from adults assembling the product. Children should never be involved during this stage. Children are at far greater risk of serious injury from improper assembly. Take caution when attaching springs.
4. - If a part of the trampoline is faulty or ages excessively. Replace only with Tuff Bounce parts.
5. - Children under the age of 6 must not use this product.
6. - A legal adult must supervise use at all times.
7. - The trampoline must be exposed to the elements as little as possible.
8. - The trampoline must never be placed on a slope or gradient when in use or otherwise.
9. - The trampoline must always maintain a clearance of 5m vertically from the bounce mat upwards from surrounding objects (roofs or overhanging branches), as well as 1.5m on any given side. (Shown in diagram on page 3). This is to prevent users from making unwanted contact with overhanging or nearby objects.
10. - Trampoline must not be placed on top of objects, nor can objects be stored underneath or around it.
11. - Trampoline must only be used in daylight hours and never in poorly lit areas.
12. - The owner is responsible for assuring all users are aware of rules and guidelines within this book prior to use.
13. - Do not attempt flips or somersaults.
14. - Do not attempt to overload the trampoline. Ensure a 1 person maximum limit is observed at all times.
15. - Do not exceed the 150kg weight limit of the trampoline at any time.
16. - Ensure the safety net is properly assembled, secured and zipped closed before use. Failure to do this can result in serious injury or death.

TRAMPOLINE LOCATION REQUIREMENT

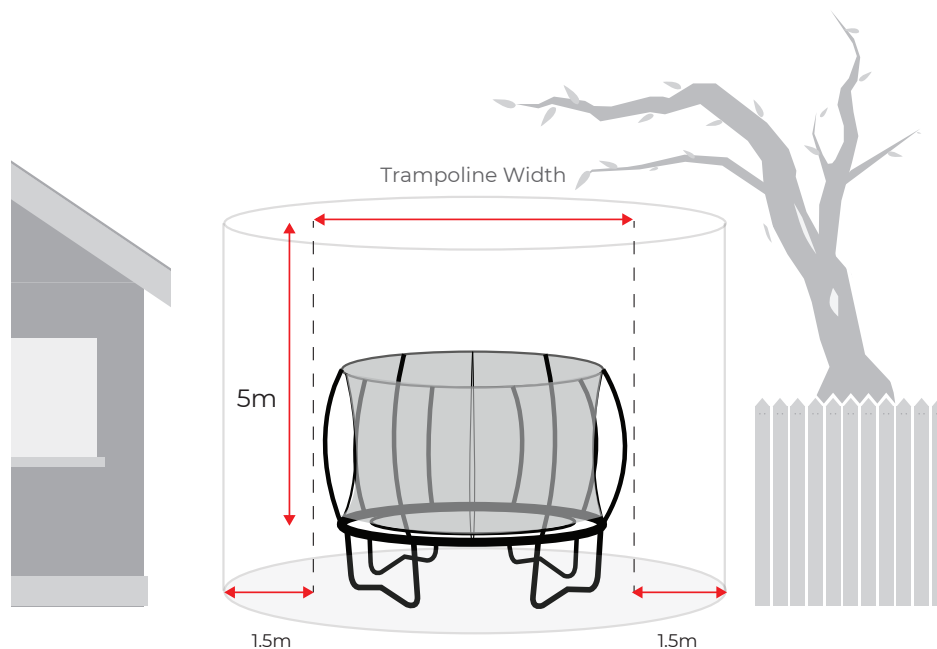

Correct Installation

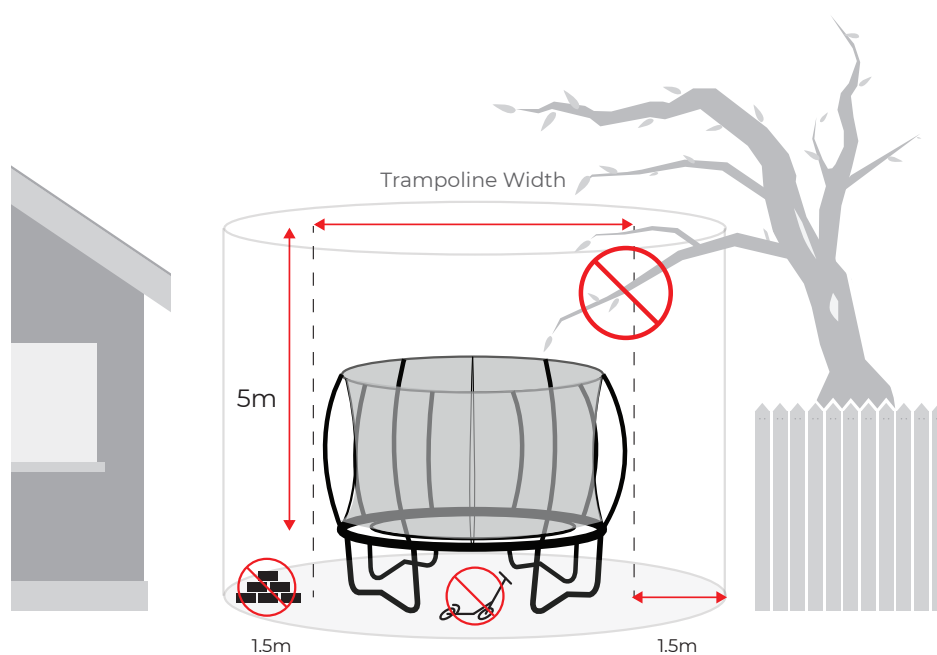

Incorrect Installation

Correct installation trampoline location requirements must be observed at all times.

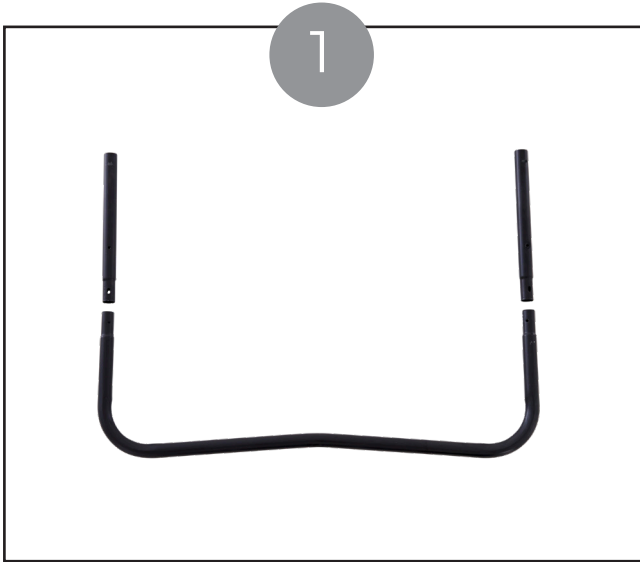

Locate the U-Shaped trampoline leg bases to form the underside of your trampoline.

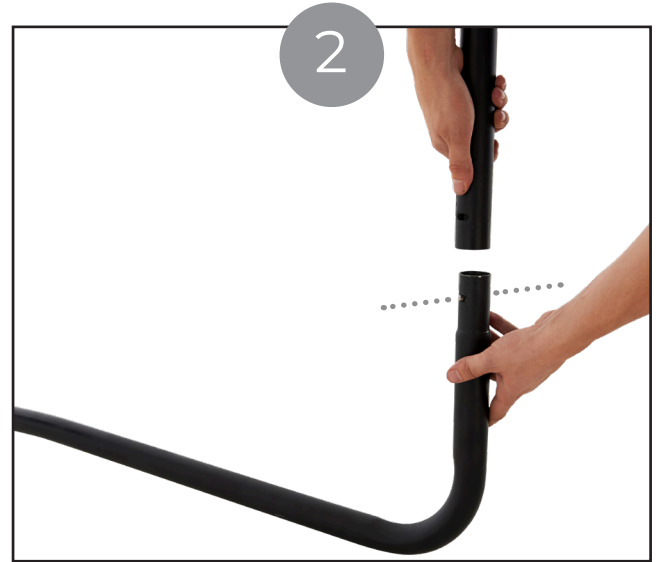

Align leg supports with their extensions, and connect together. Securing process shown in step 3.

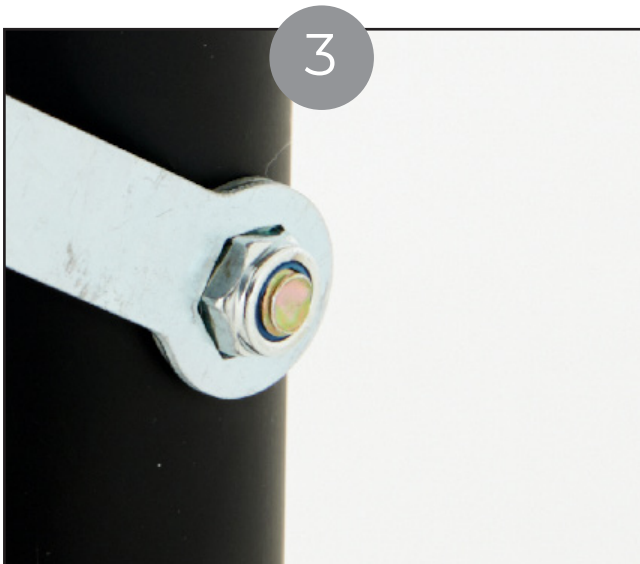

Locate the 8 medium length large bolts. Begin to secure the leg supports to their extensions using the spanner provided in your pack.



Locate the 8 curved poles and 'T' connector sleeves. Ensure a connector sleeve is placed between each curved pole.

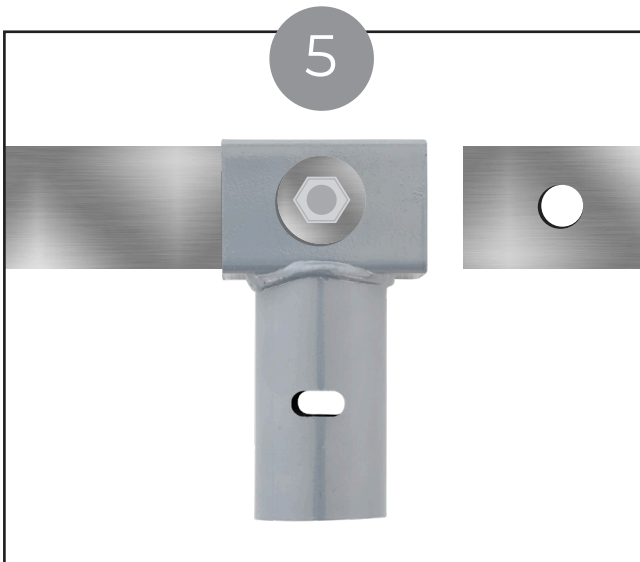

Your 8 'T' sleeve's may already be attached to one end of each curved pole. If this is the case it will contain a washer, screw and nut. Remove these, insert the connecting curved pole, then insert the screw back through the guide holes and fasten.

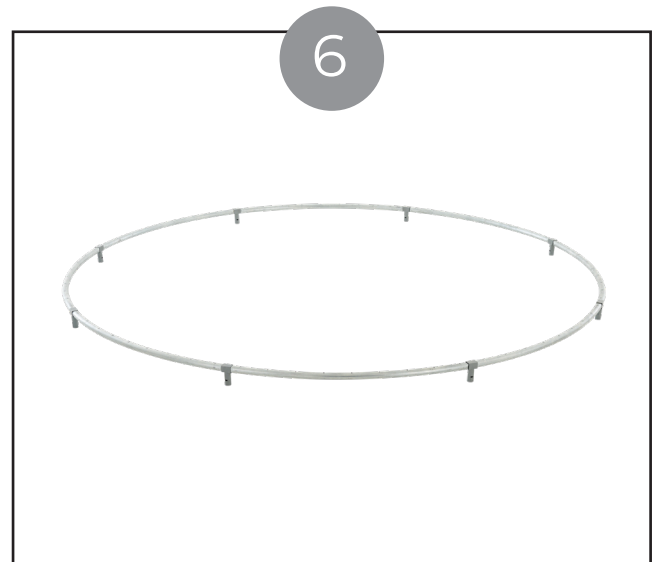

It should form a ring as shown above. A completed ring will include 8 curved poles, with 8 'T' connector sleeves between each.



Begin attaching your completed ring to each pair of trampoline legs. Do not secure with screws at this stage.

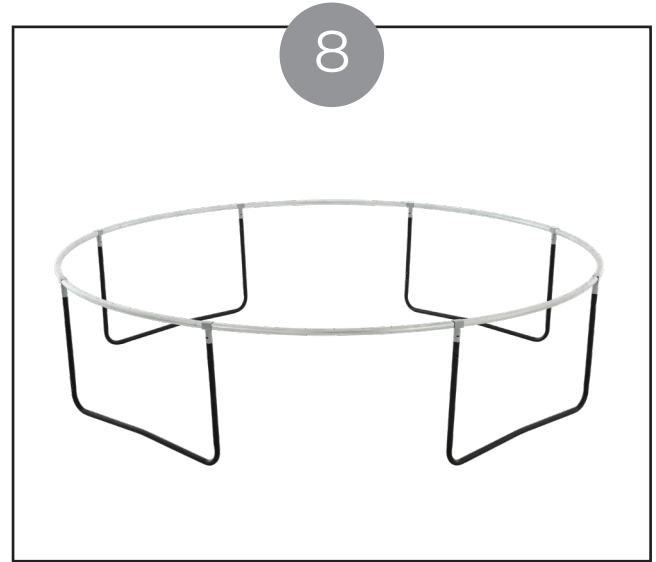

Once assembled your trampoline base is ready to stand on its own.



You will now attach the poles that will form the supports for the safety net. There are 8, and they are attached to the outside of each leg.



This diagram shows the parts required for this step in order.



Guide the long screw through both poles and secure. Ensure the new safety net pole is mounted on the outside of the trampoline leg.

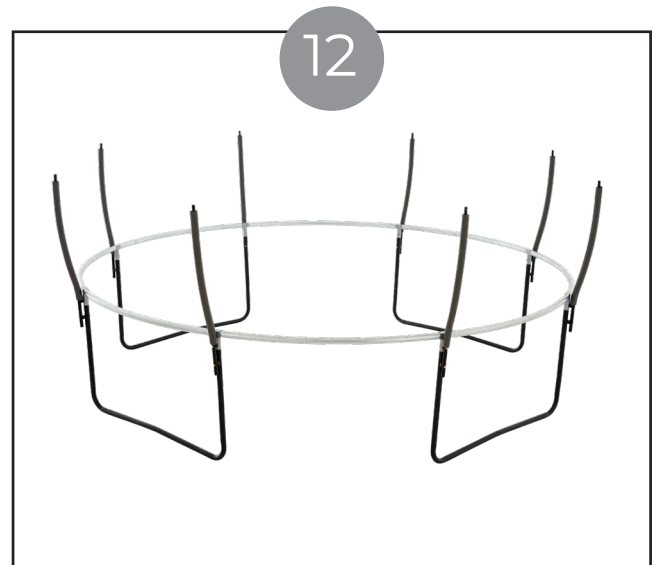

Your trampoline should look like this. The safety net poles should all bow away from the centre of the trampoline, as they are slightly curved.

13



Place your bounce mat on the ground in the middle of your trampoline frame.

14

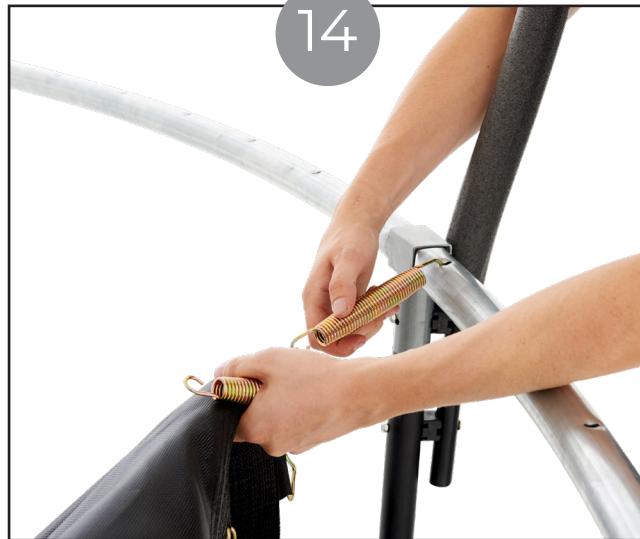

Begin to attach a spring on either side of each 'T' connector sleeves.

15



Your mat should look like this. Make sure the spring holes in the frame and mat buckles on the mat between each leg match in value.

16

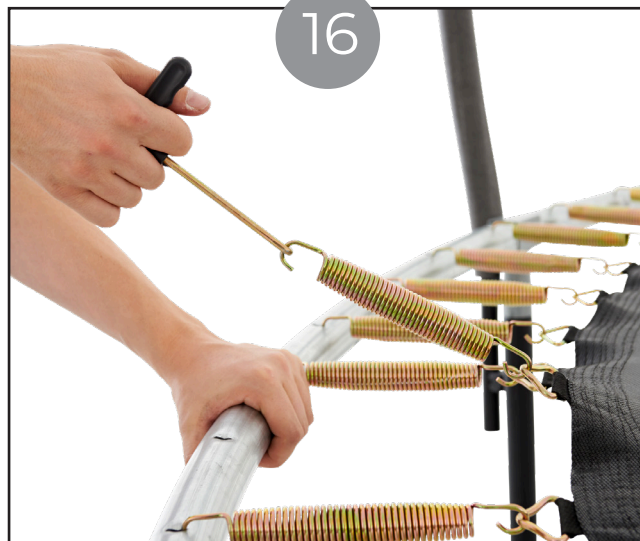

Using the spring puller provided, carefully extend and hook the springs one-by-one into their designated holes in the frame.

17

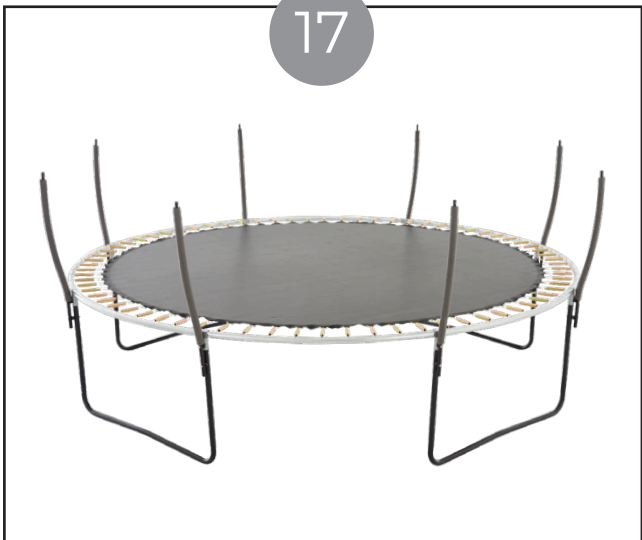

Your trampoline should be beginning to take form.

18



Locate your spring cover.



Lay spring cover over the springs equally around the trampoline, and locate the black elastic ties on its underside.



Begin to firmly tie the cover to the frame. This is essential for user safety so please ensure the knots are tight.

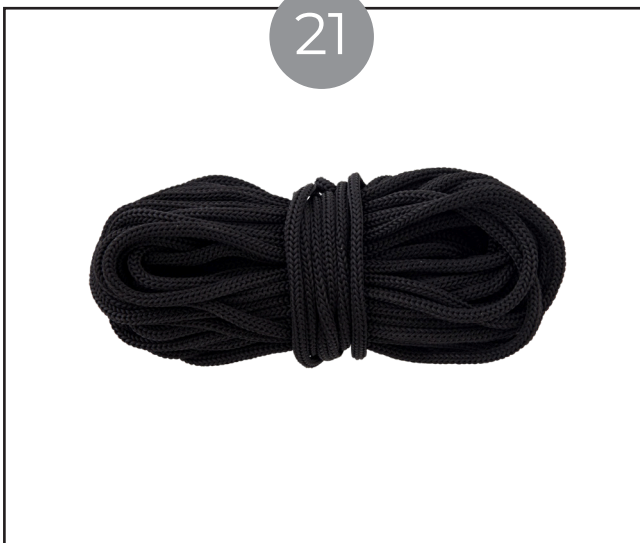

Locate your nylon string. This next step is paramount to safety in regard to underage use.

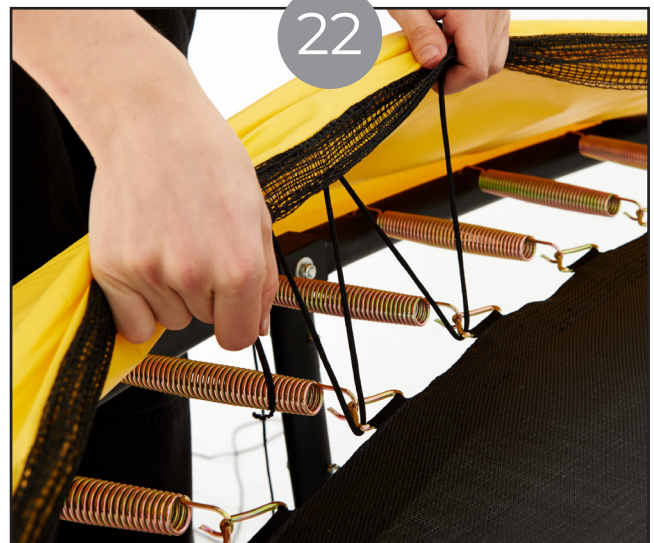

Weave the string between the mesh at the edge of the spring cover and the mat buckles in an even zig-zag fashion. Fasten until tight as possible, then tie off.



Locate the 8 extensions to your safety net poles.



Secure the 8 safety net pole extensions.

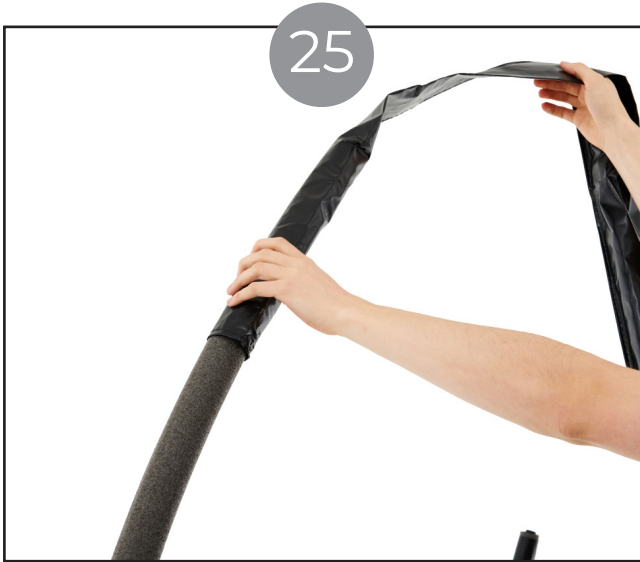

25
Locate the black safety net pole sleeves and apply them over each pole.



26
Locate your 2 fiberglass poles and form 1 large open loop. Feed the loop through the sleeves that will form the top of your safety net, then connect.



27
Sit your safety net on top of your bounce mat, ready to be connected to each safety net pole.



28
Locate each safety net pole clamp. Ensure the fiberglass runs through each designated plastic inlet, engage until you hear each metal button click.



29
When the clamp is engaged and connected it should look like this.



30
Ensure your safety net hangs inside the safety net poles and not over the top of them. Locate the safety net hooks and connect them to each mat buckle where appropriate.

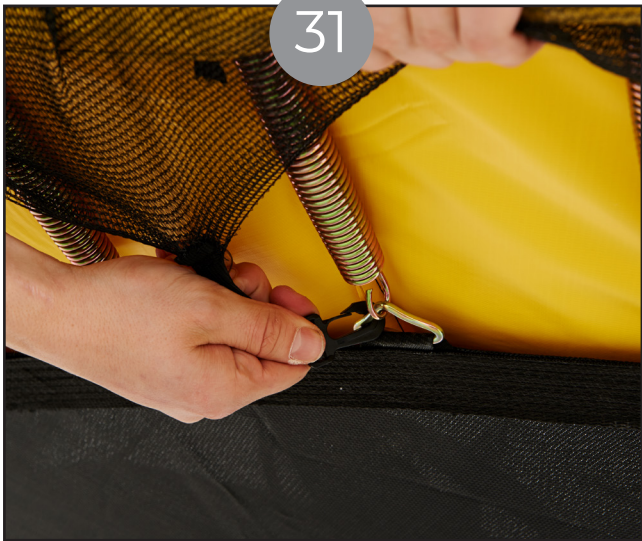

31

An engaged safety net hook should look like this.



32

Observe the net hangs within the poles, but over the outside of the frame. Your trampoline is now complete.

If you think anything is **missing** from your package, has been **damaged** in transit or you any other **issue**, please contact us at:

info@tuffbounce.com.au

tuffbounce.com.au

