



MATADOR



Before using the BBQ, remove any packaging material within and around the BBQ supplied for protection during transit.

TITAN 4

**4 BURNER BBQ WITH
CABINET AND SIDE BURNER**

Retain manual for future reference.

CONTENTS

FEATURES & BENEFITS	3
IMPORTANT INFORMATION & SAFETY	4
SAFETY	5
DO'S AND DON'TS	6
INSTALLATION & ASSEMBLY	7
POSITIONING THE BARBECUE	8
PORTABLE GAS CYLINDERS	9
LEAK TEST	10
USING THE BARBECUE	11
MAINTAINING YOUR BARBECUE	12
TROUBLESHOOTING	13
CONNECTING NATURAL GAS	14
REPLACING LIGHT BULB	15
PARTS DIAGRAM	16
ASSEMBLY INSTRUCTIONS	18
LIST OF SPARE PARTS	35
MATADOR WARRANTY	39

CONTACT INFORMATION

For spare parts order from your nearest Bunnings Warehouse.

Australia for service and warranty queries, please go to the Garth support website: www.garthsupport.com or call 1800 427 841

New Zealand for service and warranty queries, please go to your local Bunnings warehouse or call 09-9782200, Fax 09-9782222, Email Marketing@bunnings.co.nz
www.matadorbbqs.com.au



MATADOR.

FEATURES & BENEFITS



BARBEQUE DIMENSIONS

	Length	Width	Height
Hood & BBQ (4B)	850 mm	724 mm	519 mm
Cabinet (4B)	1534mm	727 mm	900 mm

NOMINAL HOURLY GAS CONSUMPTION

4 Burner	6 Burner	REAR BURNER	SIDE BURNER	SEAR BURNER
TOTAL INPUT ULPG:46 MJ/hr INJECTOR SIZE:1.1mm PRESSURE:2.75kPa	TOTAL INPUT ULPG:76MJ/hr INJECTOR SIZE:1.1mm PRESSURE:2.75kPa	TOTAL INPUT ULPG:39MJ/hr INJECTOR SIZE:0.86mm PRESSURE:2.75kPa	TOTAL INPUT ULPG:22MJ/hr INJECTOR SIZE:1.3mm PRESSURE:2.75kPa	TOTAL INPUT ULPG:20MJ/hr INJECTOR SIZE:1.22mm PRESSURE:2.75kPa
NATURAL GAS:37.5 MJ/hr INJECTOR SIZE:1.57mm PRESSURE:1.0kPa	NATURAL GAS:62.5 MJ/hr INJECTOR SIZE:1.57mm PRESSURE:1.0kPa	NATURAL GAS:9 MJ/hr INJECTOR SIZE:1.25mm PRESSURE:1.0kPa	NATURAL GAS:18MJ/hr INJECTOR SIZE:2.0mm PRESSURE:1.0 kPa	NATURAL GAS:20 MJ/hr INJECTOR SIZE:2 mm PRESSURE:1.0 kPa

IMPORTANT INFORMATION AND SAFETY

This barbecue has been tested and certified in accordance with Australia Standards AS 4557:2004 and is approved for sale and distribution in Australia and New Zealand.

- Read the Instruction Manual thoroughly before assembling or using the appliance.
- Use OUTDOORS ONLY.
- Before installing the barbecue, consider the location of the gas supply and routing of the gas line. When choosing a location for your barbecue, keep in mind that it should not be located under or against any burnable surface.
- Before using the BBQ, remove any packaging material supplied within and around the BBQ for protection during transit.
- Any modifications to this barbecue may be dangerous. Parts sealed by the manufacturer or their agent must not be manipulated by the user.
- Never alter or modify the regulator or gas supply assembly.
- **WARNING:** Accessible parts may be very hot, please keep young children away.
- Do not move the appliance during cooking.
- Turn off the gas supply at the gas cylinder after use.

WARNING LABELS & STICKERS

Each barbecue has a number of permanent labels and point of sale (POS) stickers. While all POS should be removed prior to using, the permanent heavy duty labels should NOT be removed.

DATA PLATE:

Located on the body of your barbecue you will find the silver data label which contains important information relating to the testing and approval of this product, as well as the serial number and manufacturing date.

Always refer to the details on this data plate, if you need to contact the manufacturer for information, technical support or to order spare parts.

Record the serial number, place and date of purchase on the Warranty pages at the end of this document, for quick future reference.

Garth Australia Pty Ltd Level 16, 545 William Street Melbourne, Victoria, 3000 AUSTRALIA T: +61 3 9998 7886 F: +61 3 9591 7887 www.garthaustralia.com									
MANAOKER 4 2000 WATTAGE <input type="checkbox"/>	MANAOKER 8 2000 WATTAGE <input type="checkbox"/>	MANAOKER REAR BURNER 2000 WATTAGE <input type="checkbox"/>	MANAOKER WOK BURNER 2000 WATTAGE <input type="checkbox"/>	MANAOKER SEAR BURNER 2000 WATTAGE <input type="checkbox"/>					
TOTAL INPUT <input type="checkbox"/> LPG 10 100psi SELECTOR SIZE: 4.1 mm PRESSURE: 2.75kPa NATURAL GAS 20 10psi SELECTOR SIZE: 1.67 mm PRESSURE: 1.0kPa	TOTAL INPUT <input type="checkbox"/> LPG 10 100psi SELECTOR SIZE: 4.1 mm PRESSURE: 2.75kPa NATURAL GAS 20 10psi SELECTOR SIZE: 1.67 mm PRESSURE: 1.0kPa	TOTAL INPUT <input type="checkbox"/> LPG 10 100psi SELECTOR SIZE: 4.1 mm PRESSURE: 2.75kPa NATURAL GAS 20 10psi SELECTOR SIZE: 1.67 mm PRESSURE: 1.0kPa	TOTAL INPUT <input type="checkbox"/> LPG 10 100psi SELECTOR SIZE: 4.1 mm PRESSURE: 2.75kPa NATURAL GAS 20 10psi SELECTOR SIZE: 1.67 mm PRESSURE: 1.0kPa	TOTAL INPUT <input type="checkbox"/> LPG 10 100psi SELECTOR SIZE: 4.1 mm PRESSURE: 2.75kPa NATURAL GAS 20 10psi SELECTOR SIZE: 1.67 mm PRESSURE: 1.0kPa					
6A1-400243									
<input type="checkbox"/> NZ									
CLEARANCE FROM COMBUSTIBLE MATERIALS									
R25 6262 SIDES AND BACK: 1800mm VERTICAL ABOVE: 1000mm									
Use licensed LPG retailer gas inlet pressure 2.75 kPa to cylinder pressure Natural gas inlet pressure 1.15 kPa to 3.6 kPa									
<input type="checkbox"/> INPUT: 230-240 Vac 50Hz pH=0.07 OUTPUT: 12Vdc 1.67A 20VA a. Use only with a GFI protected outlet. b. Use only outdoor units approved for outdoor use marked with W-A and rated for the power of this appliance.									
SERIAL NUMBER:					DATE:				
FOR OUTDOOR USE ONLY									

SAFETY COMPLIANCE LABEL:

While there is a requirement under the Regulations for all gas products to be safe, the Australia / New Zealand regulatory environment establishes the limits of fundamental safety.

The Safety Compliance Label confirms that this barbecue has been certified as compliant and deemed suitable for importing and operation in Australia / New Zealand.



WARNING: The appliance must not be used indoors.

Contact your local Municipality for any building codes regulating outdoor barbecue installations.

When using an ULPG supply system in an enclosure, ventilation must be provided. Gas vapour is highly explosive and can cause serious injury if allowed to accumulate in a confined space and ignited.



MATADOR

SAFETY

How do I use a ULPG Appliance Safely?

The safety record for gas appliances in Australia and New Zealand is excellent, and reflects both the high quality of appliances sold as well as growing consumer awareness about safe practice.

It is important that you READ THE MANUFACTURER'S INSTRUCTIONS thoroughly. If you have any questions or doubts, call the retailer or visit the Garth Support website.

www.garthsupport.com

If there is a leak:

- Turn the cylinder off.
- Ventilate the area to disperse gas.
- Check all connections.
- If the leak persists, keep the cylinder upright and take outside if possible. Keep skin away from any gas or liquid escaping from the cylinder.
- Keep the cylinder at least 20 metres away from any sparks or ignition sources, including electrical equipment, camera flashes, engines and motors.
- Disperse gas by encouraging maximum ventilation and spraying with a fine water spray.

If there is a fire:

- If the fire is at the barbecue, turn the gas off at the cylinder. Smother the flames with a wet cloth, fire blanket or extinguish using a fire extinguisher.
- If the fire is at the cylinder, or you can not get to the valve to turn the gas off, contact the fire brigade immediately.
- Using a garden hose, direct the water to the middle of the cylinder to keep it cool. Try not to extinguish the flame. At least if the gas is burning, it won't be able to build up pressure and explode.

Setting Up The Drip Tray

- Line the primary drip tray with foil.
- Put a fat absorbent material NOT sand or kitty litter in the small secondary drip tray.
- Ensure you regularly clean and replace the foil and fat absorber.
- Fat fires from the result of an excessive build up of grease and fats are NOT covered by Warranty.

A Note on Fire Prevention:

Most fires in outdoor barbecues are caused by a build up of fats and greases. Regularly cleaning of your barbecue is recommended. Refer to the Maintaining Your Barbecue section in this booklet for further information or visit the Garth Support website.

- NEVER operate this barbecue without a regulator.
- NEVER alter or modify the regulator or gas supply assembly.
- DO NOT connect your barbecue to an unregulated gas cylinder.
- DO NOT connect your gas barbecue to a gas cylinder exceeding this capacity
- TURN OFF the gas supply at the gas cylinder after use.
- DO NOT store empty or full spare gas cylinders under or near this or any other appliance
- Keep the gas hose away from hot surfaces and protect from dripping grease. Avoid unnecessary twisting of the hose. Visually inspect the hose prior to each use for cracks, excessive wear or other damage. Replace the hose if necessary.
- NEVER test for gas leaks with a lit match or open flame.
- NEVER light the barbecue with the hood closed or before checking the burner tubes are seated over the gas valve orifices.
- This barbecue must not be used indoors.
- WARNING: Accessible parts may be very hot. Keep young children away.
- This appliance must be kept away from flammable materials during use.
- Ensure that the barbecue is on a level and stable surface.
- DO NOT move this barbecue during use.
- Remove the drip tray before moving.

DO'S

- ✓ Have ULPG cylinder (LP units) filled by an authorised ULPG supplier.
- ✓ Check all gas line connections for leaks with a soapy solution prior to lighting and tighten until bubbles disappear.
- ✓ Preheat the barbecue for 2 - 5 minutes before cooking.
- ✓ After cooking, turn knob to hi setting for 5 minutes to burn off excess grease deposits. Then turn off gas at the knob and at the cylinder.
- ✓ Turn the gas off promptly should you be unable to light the barbecue immediately. Wait one minute before attempting to light again.
- ✓ Have proper tools, tongs, mittens and hot pads ready prior to removing foods.
- ✓ Trim excess fats from meats to minimize flare-ups.
- ✓ Let the barbecue cool before removing any parts for cleaning.
- ✓ Be careful of the control valve setting, hi - lo. A lower setting may generally be preferred.
- ✓ Minimum gas cylinder requirement is 9kg.



DON'TS

- ✗ Don't install the barbecue closer than 1000mm on the sides or 1000mm in the back to any combustible surface or less than 1 meter beneath any overhead combustible construction.
- ✗ Don't attempt any adjustment of the regulator. It has been preset and tested.
- ✗ Don't allow the ULPG cylinder to lie on its side. Keep it in an upright position.
- ✗ Don't turn a control knob on until a lighted match is inserted in the lighting hole ready to light burner (Manual ignition only).
- ✗ Don't use plastics or untempered glass utensils on the barbecue.
- ✗ Don't wear long loose flowing clothing around the barbecue. Long flowing hair is also easily ignited, especially by unexpected flare-ups. Tie hair back or wear a hat or scarf.
- ✗ Don't put food on the barbecue and leave it unattended or unwatched for long periods. Most fats can catch fire even on the lower setting.
- ✗ Don't use caustic materials to clean barbecue parts.
- ✗ Don't exceed temperature of 480°F or 250°C with the hood closed.



Do not replace the grill with an extra hotplate. You will violate the gas approval and your warranty will be voided. The grill provides the ventilation needed for the barbecue to operate safely, it is not designed to be a solid hotplate device.

WARNING!



MATADOR

INSTALLATION & ASSEMBLY

It is important to read these instructions thoroughly. If you have any problems, contact the manufacturer or contact the retailer.

1. The appliance must be installed in accordance with these Instructions and Installation requirements of the local Gas Authority and installation code AS-NZS 5601.
2. Before installing the barbecue, consider the location of the gas supply and routing of the gas line. If connecting to Natural Gas (approved models only), please refer to instructions on page 14. When choosing a location for your barbecue, keep in mind that it should not be located under any burnable surface. All sides, including the back, should not be any closer than 1000 mm for a combustible surface. A minimum clearance height of 1 meter is required from any combustible surfaces overhead.
3. After connecting the gas supply, turn on the gas ensuring all gas valves are in the OFF position and check for leaks by brushing a soap and water solution over all joints. The presence of bubbles indicates a leak. Under no circumstances should a naked flame be used to check for leaks. If a gas odour is present and no leaks can be found, do not use the barbecue and refer to place of purchase.
4. Light each burner separately and inspect the flames. They should be a soft blue colour, with an occasional yellow tip. If the burner is noisy and the flames are sharp and bright blue, or conversely, is hazy with considerable yellow or there is a lack of heat from the burner, please clean the burners as detailed under Maintaining your Barbecue. If this does not rectify the problem please refer to the place of purchase.
5. If, after following the instructions, satisfactory performance cannot be obtained, please refer to your place of purchase.
6. **Seasoning the Cooking Surfaces**
 - Before using the BBQ for the first time, the cooking surfaces should be washed with a mild soap and water solution to remove any dust.
 - Dry the cooking surfaces and then apply a light coating of cooking oil.
 - Light your barbecue for the first time and turn all the burners to the LO position.
 - Leave burners alight for 30 minutes for curing.
 - Your barbecue is now seasoned and ready for your first barbecue.
7. **Service**

Other than general cleaning, servicing of this barbecue must be carried out by an authorised person.

NOTE: The regulator thread that connects to the cylinder is threaded anticlockwise.

NOTE: If your appliance fails to operate Successfully, please go to the Garth Support website: www.garthsupport.com or call 1800427841 (Australia), 0800357050 (New Zealand) for warranty assistance

POSITIONING THE BARBECUE

This appliance should only be used in an above ground, open air situation with natural ventilation, without stagnant areas, where gas leakage and products of combustion are rapidly dispersed by wind and natural convection.

Any enclosure in which the appliance is used shall comply with one of the following:

- An enclosure with walls on one side, but at least one permanent opening at ground level and no overhead cover.
- Within a partial enclosure that includes an overhead cover and no more than two walls.

Within a partial enclosure that includes an overhead cover and no more than two walls, the following shall apply:

- At least 25% of the total wall area is completely open; and
- At least 30% of the remaining wall area is open and unrestricted.

In the case of balconies, at least 20% of the total of the side, back and front wall areas shall be and remain open and unrestricted.

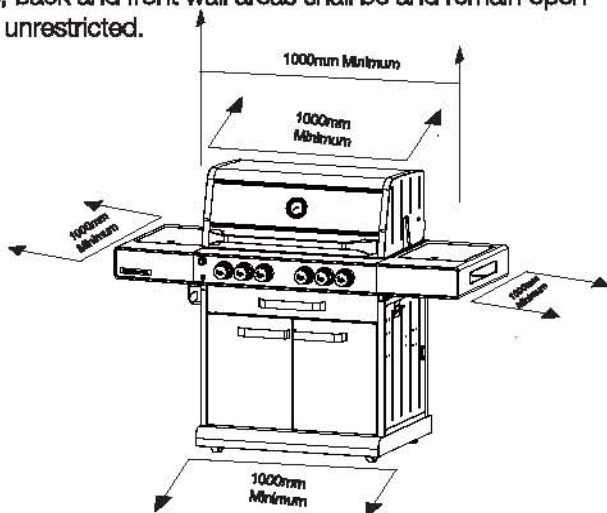

Minimum Distances from Combustible Material

The barbecue must not be installed under or on any combustible material. Minimum clearance from any combustible materials of ALL sides of the barbecue is 1000mm and 1000mm overhead.

BARBECUES MUST BE INSTALLED IN ACCORDANCE WITH THE MANUFACTURER'S INSTALLATION INSTRUCTIONS, LOCAL GAS FITTING REGULATIONS, MUNICIPAL BUILDING CODES AND THE GAS INSTALLATION CODE AS/NZS 5601.

The following figures are diagrammatical representations of outdoor areas described. Rectangular areas have been used in these figures - the same principle applies to any other shaped area.

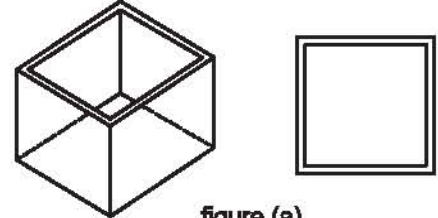

figure (a)

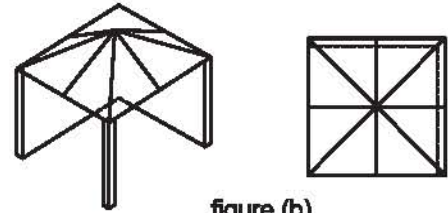

figure (b)

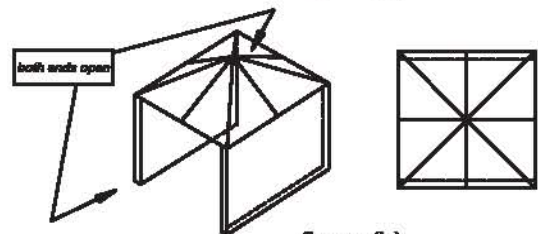

figure (b)

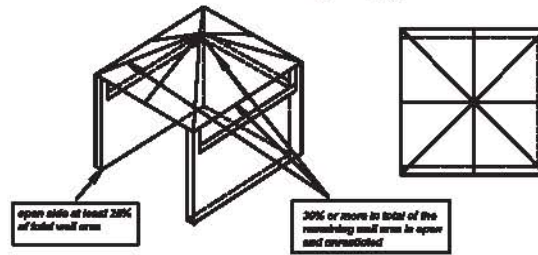

figure (c)

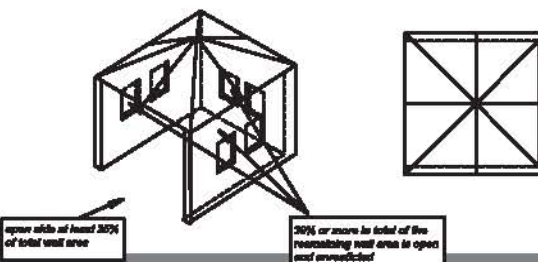

figure (d)

This appliance shall only be used in an above ground open-air situation with natural ventilation, without stagnant areas, where gas leakage and products of combustion are rapidly dispersed by wind and natural convection.

Any enclosure in which the appliance is used shall comply with one of the following:
An enclosure with walls on all sides, but at least one permanent opening at ground level and no overhead cover.
Within a partial enclosure that includes an overhead cover and no more than two walls.



MATADOR

PORTABLE GAS CYLINDERS

What is ULPG?

ULPG is fuel gas compressed until it turns to liquid, then stored in a bottle or cylinder under pressure for easy transport.

The minimum size gas bottle to be used for this BBQ is 9Kg

How is it different from Natural Gas?

ULPG is similar to natural gas. It is colorless, non-poisonous and does not pollute when burnt. Appliances, like heaters or barbecues, that can work on natural gas can often be converted to work on ULPG and vice versa. There is one important difference - ULPG is heavier than air so if it escapes it does not float away. Instead ULPG will collect and form in gas pools at ground level or at the bottom of your appliance.

How do I connect the appliance to the gas cylinder?

There are three types of connection to ULPG cylinder. Some appliances require a hose and regulator. The regulator is a device attached to the hose to reduce the gas pressure.

The Dataplate on these appliances should indicate the correct pressure – e.g. “ULPG pressure, 2.75kPa.”

Other appliances simply require a hose. These deliver gas at high pressure to the appliance. The dataplate on these should read “Cylinder Pressure Only”.

Finally, some appliances are designed for direct connection to a certain type of cylinder (e.g. Primus or Companion). The data plate on these appliances should read “Cylinder Pressure Only”.

How do I use the Gas Cylinder?

Most ULPG cylinders work basically the same. There is a valve handle at the top, which you turn to release the gas. This works the same as a water tap, except that the gas is released at high pressure. Portable appliances often have a short length of hose which connects the gas bottle to the appliance.

A few simple rules here:

1. Store the cylinder safely

When you are not using your ULPG cylinder, store it where it cannot be knocked around and damaged. Store it away from direct heat and make sure that the area is well ventilated in case of slow leaks building up. Also, keep away from any other bottles of compressed gases and if possible, use a cylinder sealing plug to prevent leaks.

2. Always keep the cylinder upright.

3. Refilling

When the cylinder runs out of ULPG, please swap the empty gas bottle for a full one through any gas exchange program.

4. Inspection

If you do not have a cylinder exchange program available in your area and have your gas cylinders filled, have the cylinder inspected EVERY 10 YEARS at an authorised testing station. The date of every inspection is imprinted onto the cylinder itself.

5. Repairs

Do not tamper with any fitting attached to any ULPG gas cylinder. Contact the supplier or an authorised testing station

6. Keep protected from heat

Heat will increase the pressure inside the bottle due to the ULPG expanding. This could cause the safety valve to open and allow gas to escape. If the cylinder feels hot to the touch, keep the cylinder shielded from the appliance.

7. Hose Inspection

Check the gas hose and fittings for deterioration once a year or whenever replacing the gas cylinder. The hose must be replaced if it is cracked, split, cut or damaged.

IF THERE IS A GAS LEAK

1. Turn the gas cylinder off.
2. Ventilate the area to disperse any accumulated gas.
3. Check all connections.
4. If the leak persists, keep the cylinder upright and take to an open area.
5. Keep skin away from any gas or liquid escaping from the cylinder.
6. Keep the cylinder at least 20 meters away from any sparks or ignition sources including electrical equipment, camera flash, engines or motors.
7. Disperse gas by providing maximum ventilation and spraying with a fine water spray.

Always turn off the gas supply at the gas cylinder after use.

GAS LEAK TEST

Before lighting your barbecue it is important to carry out this simple test to check whether the gas cylinder, hose and regulator are working / connected correctly.

NEVER TEST FOR GAS LEAKS USING A LIT MATCH OR OTHER NAKED FLAME

①

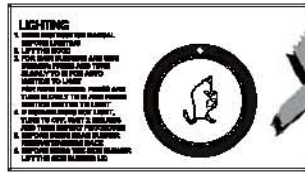
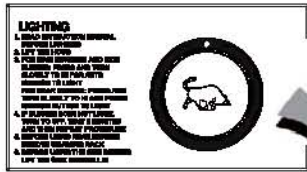

TURN OFF THE GAS VALVE

②

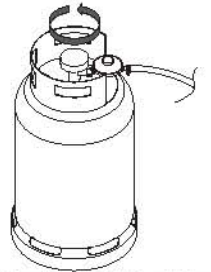

TURN ON THE GAS BOTTLE

③

MAKE SOAPY WATER SOLUTION

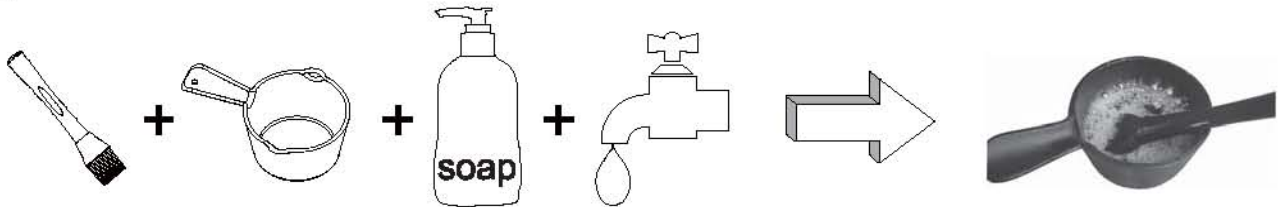

④

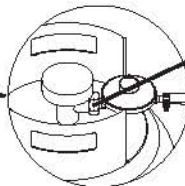
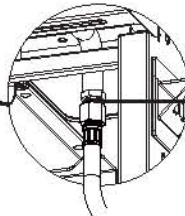
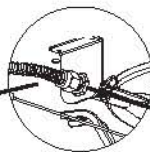
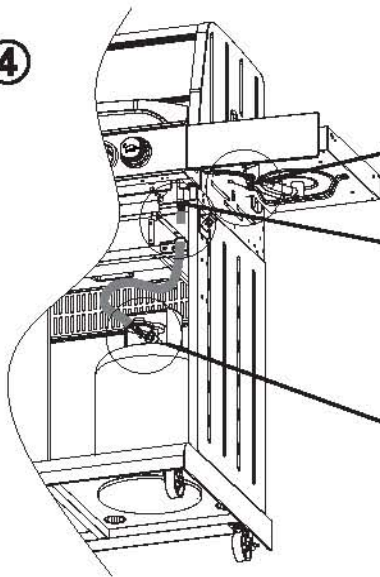

CHECK FOR LEAKS BY BRUSHING A SOAP AND WATER SOLUTION OVER ALL JOINTS. THE PRESENCE OF BUBBLES INDICATES A GAS LEAK.

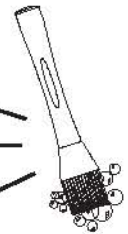

⑤

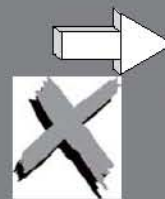
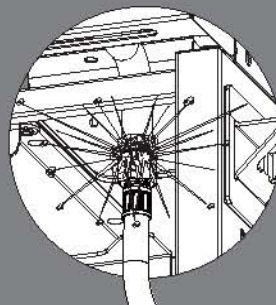
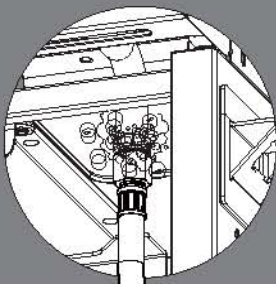

RE-TIGHTEN THE CONNECTION IF GAS LEAKAGE OCCURS



MATADOR.

USING THE BARBECUE

LIGHTING INSTRUCTIONS

This BBQ uses a new type of ignition system; please see below for lighting procedures

NOTE: Light all main burner before lighting the side burner.

1. READ INSTRUCTION MANUAL BEFORE LIGHTING
2. LIFT THE HOOD
3. FOR MAIN BURNERS AND SIDE BURNER: PRESS AND TURN SLOWLY TO HI FOR AUTO IGNITION TO LIGHT
FOR REAR BURNER: PRESS AND TURN SLOWLY TO HI AND PRESS IGNITION BUTTON TO LIGHT
4. IF BURNER DOES NOT LIGHT, TURN TO OFF, WAIT 2 MINUTES AND THEN REPEAT PROCEDURE
5. BEFORE USING REAR BURNER REMOVE WARMING RACK
6. BEFORE USING THE SIDE BURNER LIFT THE SIDE BURNER LID

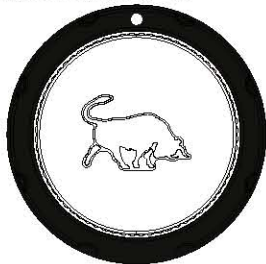

NOTE: It is important to ensure that all control valves, including the gas cylinder, are turned off after use.

FOR MANUAL IGNITION

1. Light a 90mm barbecue match or a lighting gun and hold adjacent to the lighter hole at the right end of the barbecue.

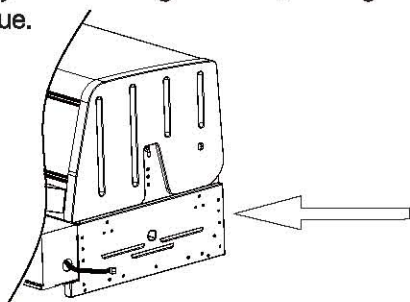

2. Turn the right hand gas control knob to the **HI** position. The burner will light from the match.
3. Once the right burner is lit, the burner next to it can be turned on and will light off the lit burner. Repeat till all burners are alight.

Each burner can be adjusted to provide a low setting by turning the gas control knob to the **LO** position.

PREHEATING

Light the burners as previously directed and turn to HI and allow the barbecue to preheat for 2 - 5 minutes.

PREPARE THE COOKING SURFACE

It is preferable to apply a light coat of cooking oil using a long handed brush to the cooking grills prior to lighting each time, the oil will keep food from sticking to the cooking surface.

USING THE HOOD WHEN COOKING

When using the barbecue with the hood closed, use the two outside burners only and do not exceed 250°C. Exceeding 250°C can damage the barbecue and void your warranty.

FLARE-UP CONTROL

Anytime you cook meat above an open flame you will have flare-ups which are caused when the natural juices from the meat fall on the flame tamers (diffusers) below the cooking plates.

Flare-ups, and the resulting smoke, are what give meat cooked over an open flame that delicious outdoor flavour. So expect and encourage some flare up.

However, excessive flaring can be caused by cooking extra fatty or marinated foods directly on the grill plates, by cooking with too high a temperature or by a build up of fats and residue in the drip tray beneath the burners.

These types of flare-ups should be controlled, or your food will burn.

To prevent excessive flare-ups, trim off excess fat from meat and poultry before placing on the grill, cook fatty or marinated meats on the barbecue plate and clean your drip tray regularly.

To control excessive flare-ups caused by too high a heat, turn the control knob down to a lower setting.

Throw a small amount of baking soda or gently spray a small amount of water (from a meat baster or spray bottle) directly onto the flame tamers to put out excessive flaring.

Do not spray aerosols in the vicinity of this appliance while it is in operation.

Do not use or store flammable materials in or near this appliance.

Do not place articles on or against this appliance.

Do not modify this appliance.

MAINTAINING YOUR BARBECUE

CARING FOR THE BURNERS & INJECTORS

To ensure continued satisfaction from your barbecue it is essential to keep the burners and injectors clean.

Under normal usage, your barbecue should be left burning for five minutes after cooking has ceased. This will burn off any excess fats, juices, etc.

Occasionally, after long cooking sessions, excess fats, juices and marinades can clog the burners. Remove the burners (see instructions below) and after brushing with a barbecue brush, wash in hot water and detergent – ensuring that all ports are free from detergent.

Rinse in water, shake of excess water and dry if possible. Return to the barbecue and light immediately to remove any remaining moisture.

Apply a light coating of cooking oil to the burners if the barbecue is not to be used for an extended period.

REMOVING THE BURNERS

1. Make sure the barbecue has been switched off and has completely cooled down if recently used.
2. Ensure all gas control knobs are set to the off position and the gas cylinder has been turned off.
3. Lift the grill plate and oil channel off the barbecue.

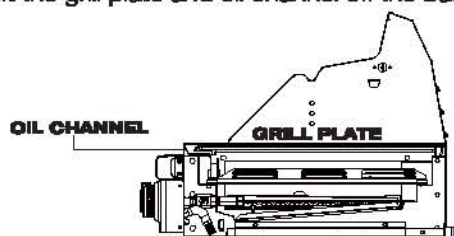

4. Lift the flame diffuser from position as shown below.

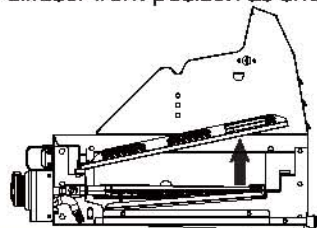

5. Remove the bolts at the rear of the BBQ from the burner.

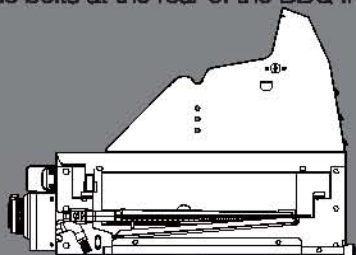

6. Lift and swing out the burner from position as shown below.

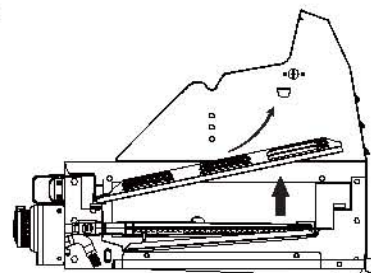

7. Simply reverse the previous procedure to reinstall the burners, flame diffuser and grill plate.

CARING FOR THE GRILLS & HOTPLATES

After cooking, turn the control knobs to the HI setting for five minutes to burn off any excess grease deposits.

Then turn off the gas at the control knob and at the cylinder. Let the barbecue cool before removing any parts for cleaning.

The grills and hotplates should be cleaned regularly depending upon usage and types of food cooked (ie sausages, fatty foods) to prevent a build up of fats and greases.

Cast Iron cooking surfaces should require washing. Simply heat the barbecue and use either a barbecue brush or tool to scrape the surface clean.

A light brushing with cooking oil should be applied to the grills and hotplates if the barbecue is not to be used for an extended period.

CLEANING THE BARBECUE

To ensure your barbecue is ready the next time you want to use it, turn all burners OFF and take a long handed brush and carefully brush off the cooking surfaces.

Remember to protect hands from the heat by using an oven mitt to hold the brush.

The barbecue body should also be cleaned regularly using hot water and detergent, depending upon usage to prevent a build up of fats and greases.

Remember to dry thoroughly and cover the barbecue securely with a weather proof cover.

Before use checks:

Remove accumulated grease and other cooking residue
Inspect the gas hose and regulator and periodically replace annually

Check all connections for gas leakage

Check gas cylinder date stamp is current



MATADOR

TROUBLESHOOTING

My BBQ will not light properly. Why?

- Check LPG gas supply.
- Check to insure all gas connections are secure, including the gas hose connection to your Side Burner (most models).
- Check that the end of each burner is positioned properly over each gas valve.

When first lighting my BBQ I have a strong smell of gas.

- Check all connections are tight & then perform a **LEAK TEST** section in this instruction.

CAUTION - BEWARE OF FLASH-BACK:

Spiders and small insects occasionally spin webs or make nests in the bbq burners during transit and warehousing. These webs can lead to a gas flow obstruction which could result in a fire in and around the front of the burner. This type of fire is known as a "FLASH-BACK" and can cause serious damage to your bbq and create an unsafe operating condition for the user.

Although an obstructed Burner is not the only cause of "FLASH-BACK", it is the most common cause.

To reduce the chance of "FLASH-BACK", you must clean the burner before assembling your barbecue. Also perform the burner cleaning procedure on page 7 if your bbq has not been used for an extended period of time.

I found a damaged part while unpacking my new barbecue from the box. How do I get a replacement part? or

While assembling my new barbecue, I realised a part is missing. Who do I contact to replace parts that were missing from my box?

Garth Australia Pty Ltd stocks replacement parts for your gas barbecue. Follow these steps for fast and accurate part replacement:

- Locate the serial number of your BBQ as found on the silver data Label. This could be located on the bottom of the front fascia of the BBQ, the right hand side of the BBQ frame, on the rear of the BBQ frame or behind the cabinet door, depending on your model. Then, it's a good idea to write the serial number & date of purchase in the **MATADOR WARRANTY** section for quick future reference.

- Then, refer to the **LIST OF SPARE PARTS** to identify the missing part(s) and go to our Garth Support website www.garthsupport.com, or contact us on our free call number:
Australia - 1800 427 841
New Zealand - 0800 357 050

Note: Recommended Maintenance

Recommended maintenance should be carried out by an authorised person every 12 (twelve) months for the life expectancy of the appliance.

For Technical Assistance

If you experience any technical issues with your barbecue, in the first instance review the instruction manual or contact the Garth Customer Support Department through the Garth Support website at www.garthsupport.com for assistance.

For Spare Parts

To order spare parts, you can return to your place of purchase and ask them to order a part for you. Alternatively, you can order directly through the Garth Support website at www.garthsupport.com

You will need to provide the following information:

- Model of Barbecue
- Year of Purchase
- Part requiring replacement (refer to the Spare Parts List in your Assembly Manual)
- Name of the warranty service company (if applicable)

CONNECTING NATURAL GAS

This barbecue model is approved for conversion from Propane to Natural Gas (for Australia only).
The following steps are required to complete the conversion:

1. Contact a registered Gas Fitter / Plumber to obtain a quote for the conversion and to confirm whether this appliance will work efficiently with the current gas supply to your household, in accordance with the Installation Code AS5601.
2. The Gas Fitter / Plumber will need to source the necessary parts for the conversion.
(Note: Replacement jets can be ordered directly from Garth with an official Purchase Order and by quoting of the Gas Fitter / Plumber's Registration Number.)
3. Upon completion of the conversion, the Gas Fitter / Plumber is LEGALLY required to issue a Compliance Certificate.
4. DO NOT attempt to complete the conversion yourself.
5. Failure to comply with these requirements and Installation Code AS 5601 will automatically void the Warranty for this product.
6. Remove the control knobs and bezels, then remove the Barbecue fascia. Replace the side burner valve with the new Natural Sear Burner N0059A

Restraining tether for appliances with hoses, for connection to fixed gas supply

Where a mobile appliance is to be connected to a fixed gas supply via a flexible hose connection, a restraining tether of adequate strength shall be fixed to the appliance and be suitable to be fixed to the wall within 50 mm of each connection point. The length of the tether shall not exceed 80% of the length of the hose assembly. NOTE: The restraining tether is intended to prevent stress being imparted onto the hose assembly when the appliance is moved out of its normal operating position.

Warning: Please make sure that the restraining tether is installed before use.

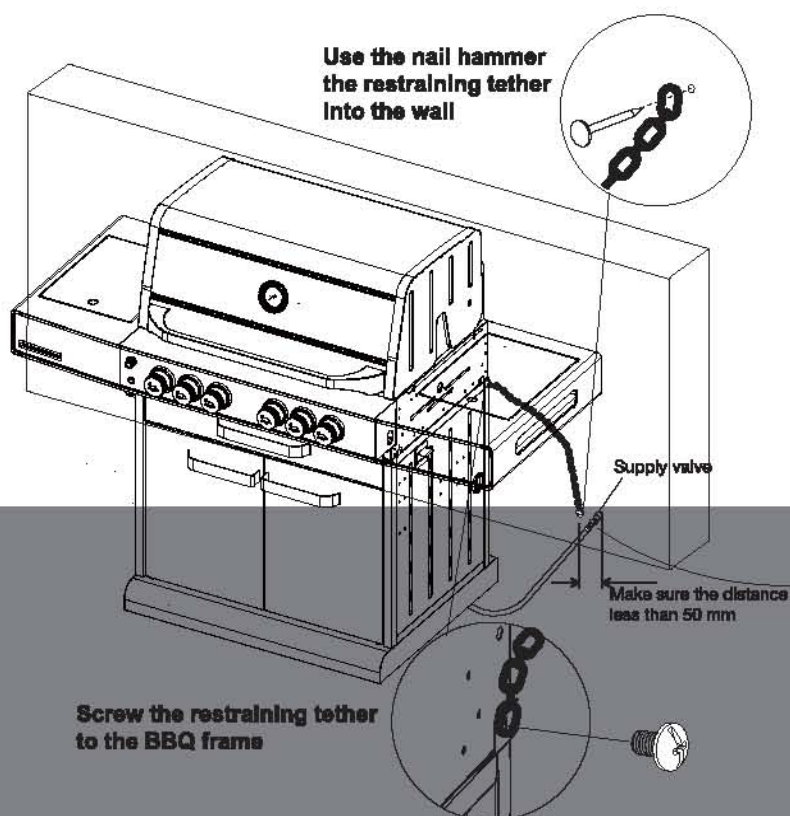

Attach the flex connector from the manifold assembly to the natural gas regulator supplied as illustrated in the Natural Gas Hose Attachment diagram. Tighten using two wrenches. (Do not use thread sealer/pipe dope.)

Note: The gas grill is designed to operate at an inlet pressure of 1.00 kPa and must be checked after installation by turning all burners on and measuring at the regulator outlet test point provided.

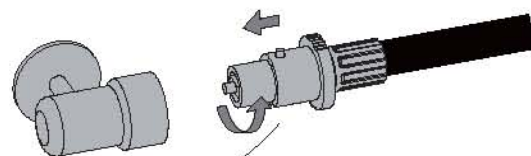

MATADOR

REPLACING LIGHT BULB

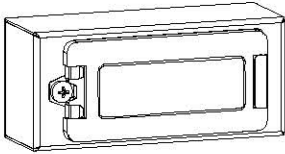

BBQ LIGHT

INPUT: 230-240 Vac 50Hz pf=0.97
 OUTPUT: 12Vac 1.67A 20VA

STEP 1.

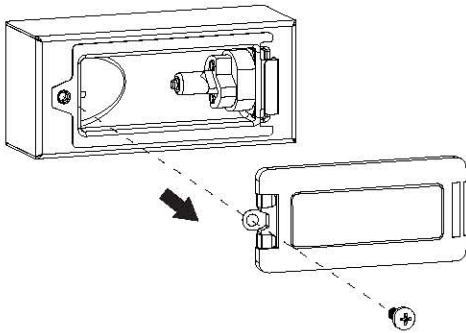

STEP 2.

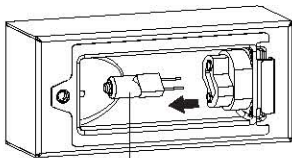

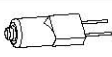
	Light Bulb Type	Maximum Voltage	Maximum Wattage
	G4	12V	10W

STEP 3.

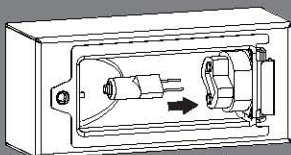

STEP 4.

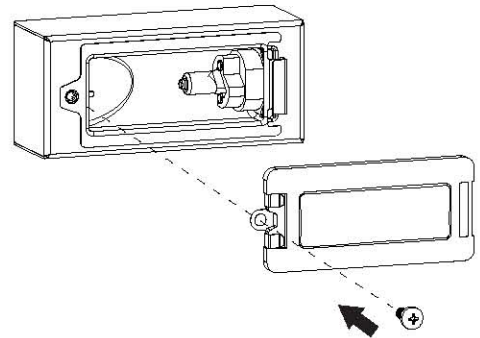

STEP 5.

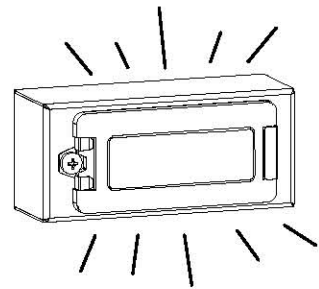

PARTS DIAGRAM

FOR 279-17



1. LOCKABLE CASTOR X2



2. UNLOCKABLE CASTOR X2

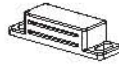

3. MAGNET X2

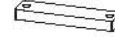

4. MAGNET HOLDER X2



5. BOTTLE OPENER



6. CABINET FRONT CROSS BAR

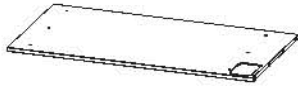

7. CABINET TOP PANEL



8. CABINET TOP PANEL HEAT SHIELD

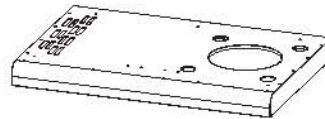

9. CABINET BOTTOM PANEL



10. SIDE SHELF ATTACHING PLATE X4

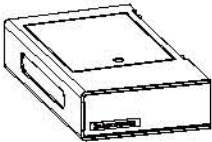

11. LEFT SIDE SHELF

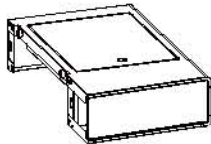

12. SIDE BURNER SHELF



13. DRAWER LEFT SLIDE



14. DRAWER RIGHT SLIDE

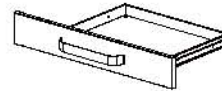

15. DRAWER



16. FAT TRAY CHANNEL X1



17. CABINET LEFT PANEL



18. CABINET RIGHT PANEL

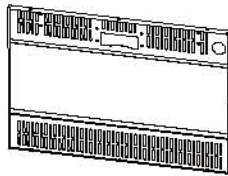

19. CABINET BACK PANEL

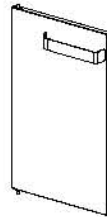

20. LEFT DOOR

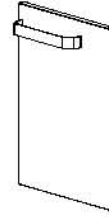

21. RIGHT DOOR



22. CONTROL KNOB X6



23. LEFT DOOR SUPPORT BRACKET



24. RIGHT DOOR SUPPORT BRACKET



25. OIL CUP



26. OIL CHANNEL



27. OIL CUP BOX

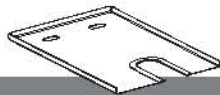

28. REGULATOR COVER

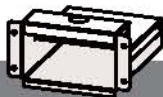

29. OIL CUP SHIELD

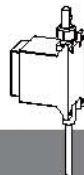

30. TRANSFORMER



31. WIRE CLIP

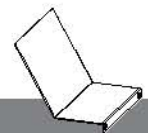

32. TRANSFORMER CABLE SEPARATION PANEL

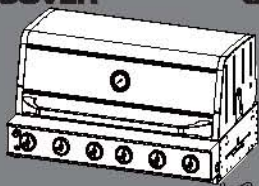

33. BBQ FRAME+HOOD X1



MATADOR

PARTS DIAGRAM

FOR B279-17

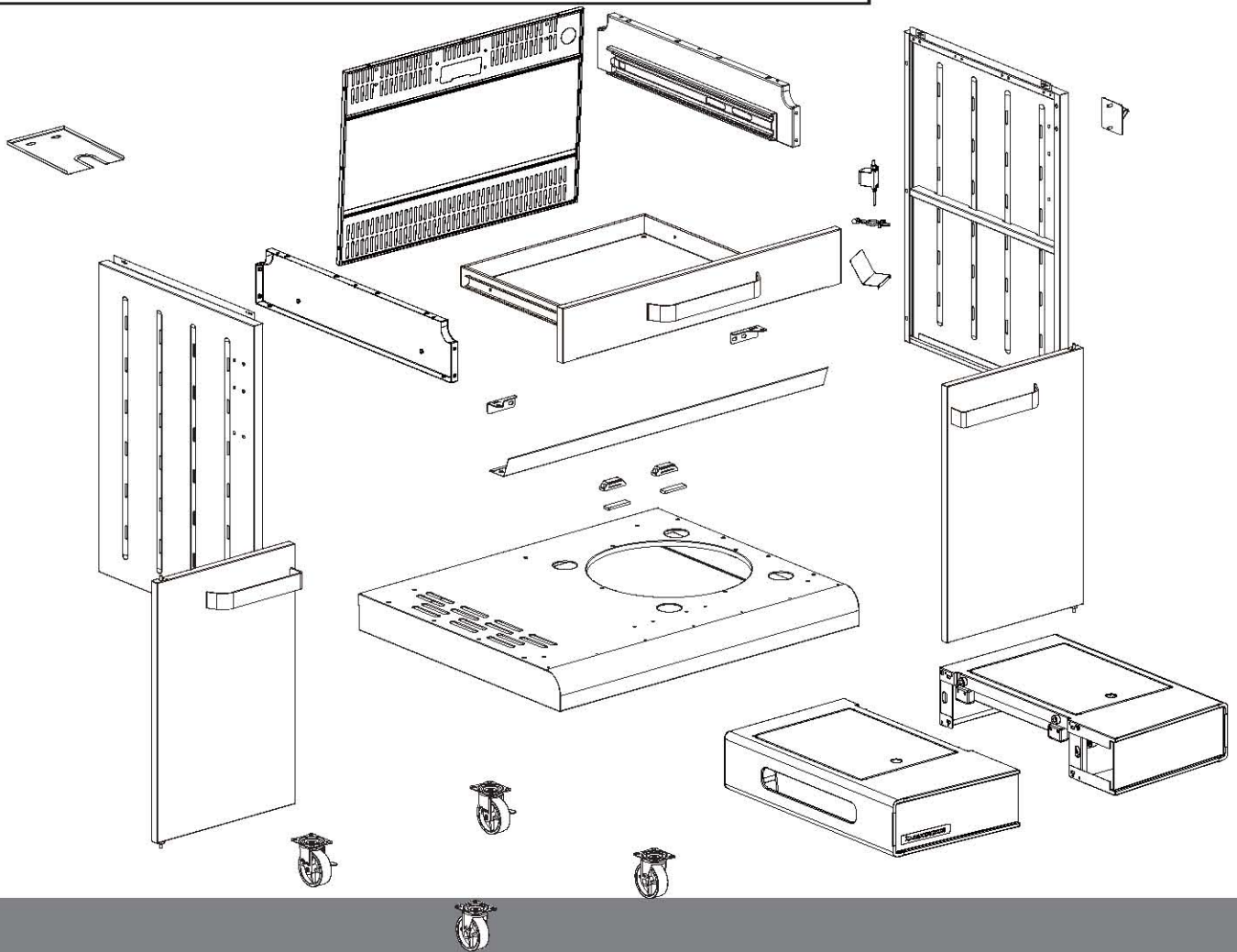
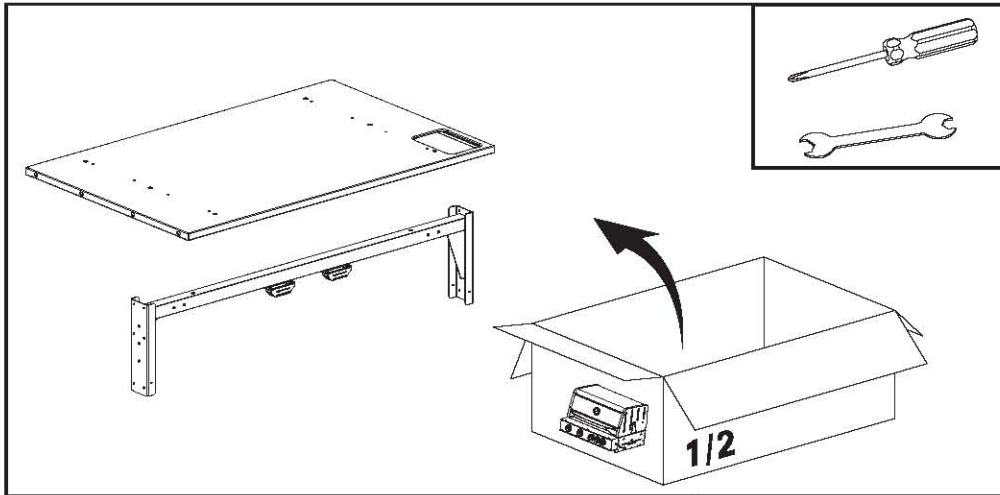

- | | | | | |
|----------------|----------------|-------------|-------------|---------------|
| 16: 6mm x 10mm | 10: 5mm x 40mm | 16: 6mm | 74: 5mm | 4: 5mm |
| 78: 5mm x 12mm | 4: 3mm x 20mm | 52: 5mm | 12: 6.5mm | 4: 5mm x 8mm |
| 2: 6mm(s/s) | 2: 5mm(s/s) | 2: 5mm(s/s) | 2: 5mm(s/s) | 4: 5mm x 20mm |

ASSEMBLY INSTRUCTIONS

STEP 1

 16: 6mm x 10mm

 16: 6mm

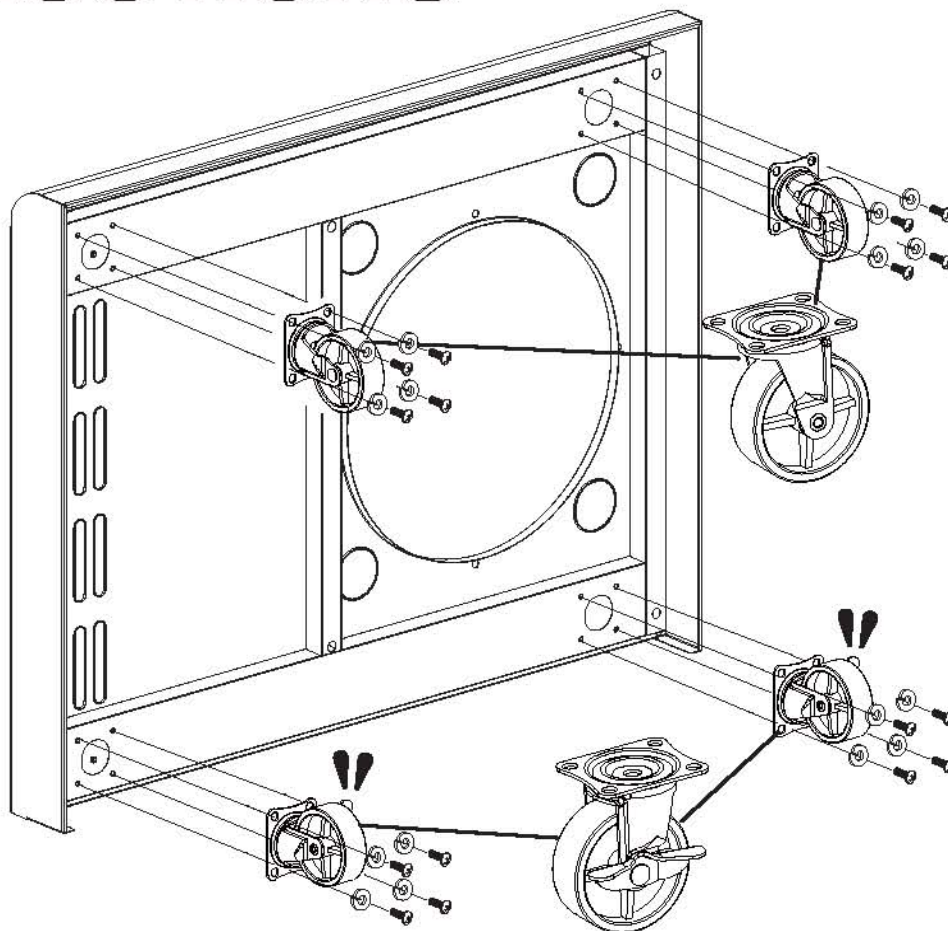

STEP 2

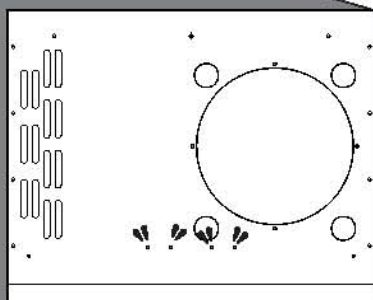
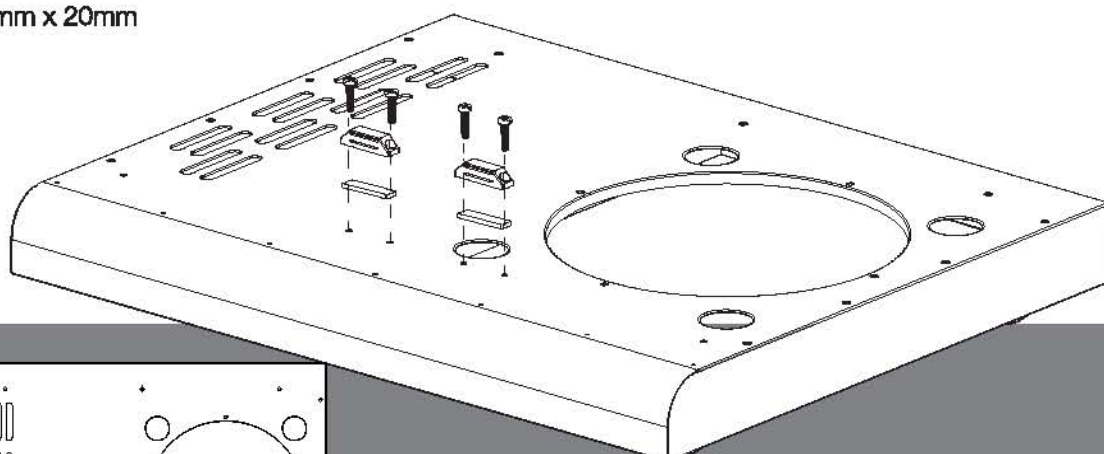

 4: 3mm x 20mm

 2:



MATADOR

STEP 3

-  4: 5mm x 40mm
-  4: 5mm
-  4: 5mm

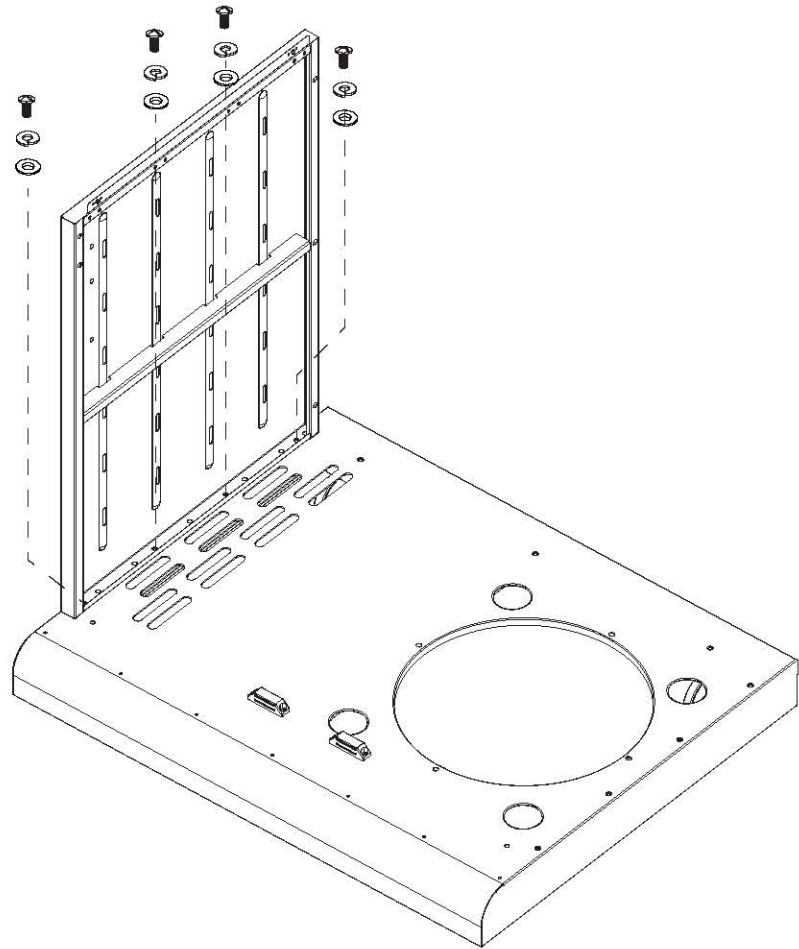

STEP 4

-  4: 5mm x 40mm
-  4: 5mm x 12mm
-  4: 5mm
-  8: 5mm
-  4: 5mm

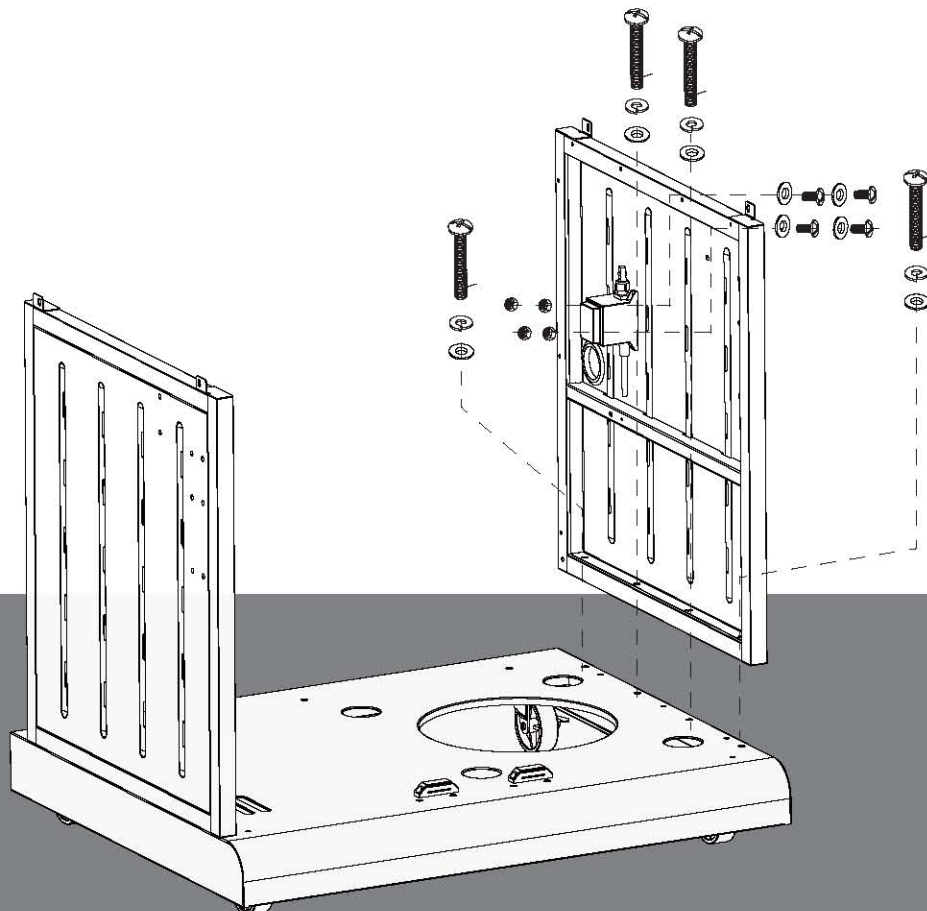

STEP 5

-  5: 5mm x 12mm
-  5: 5mm
-  5: 5mm

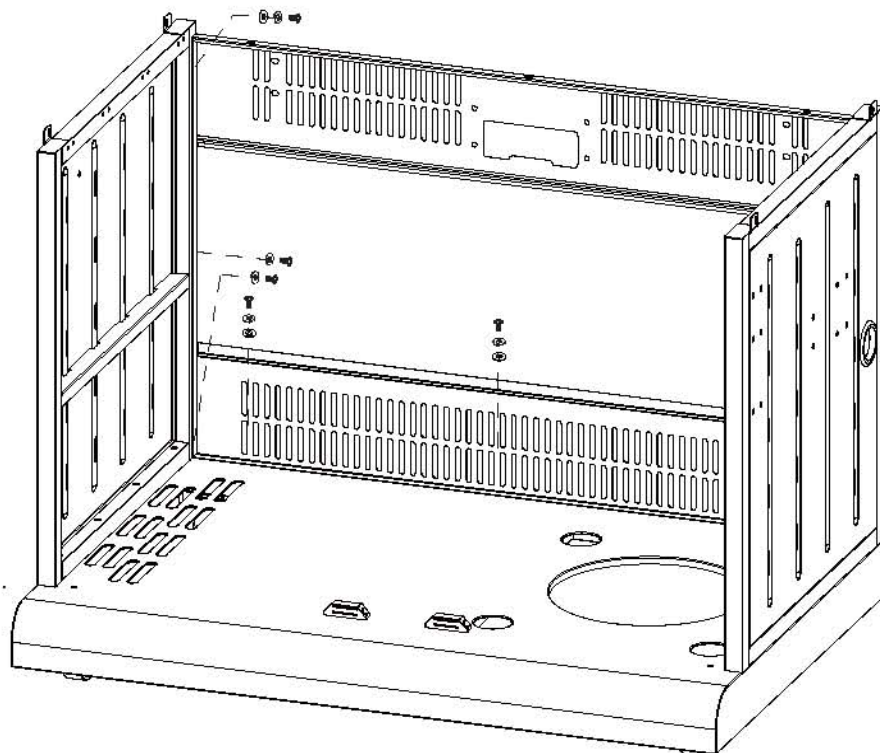

STEP 6

-  4: 5mm x 12mm
-  4: 5mm
-  4: 5mm

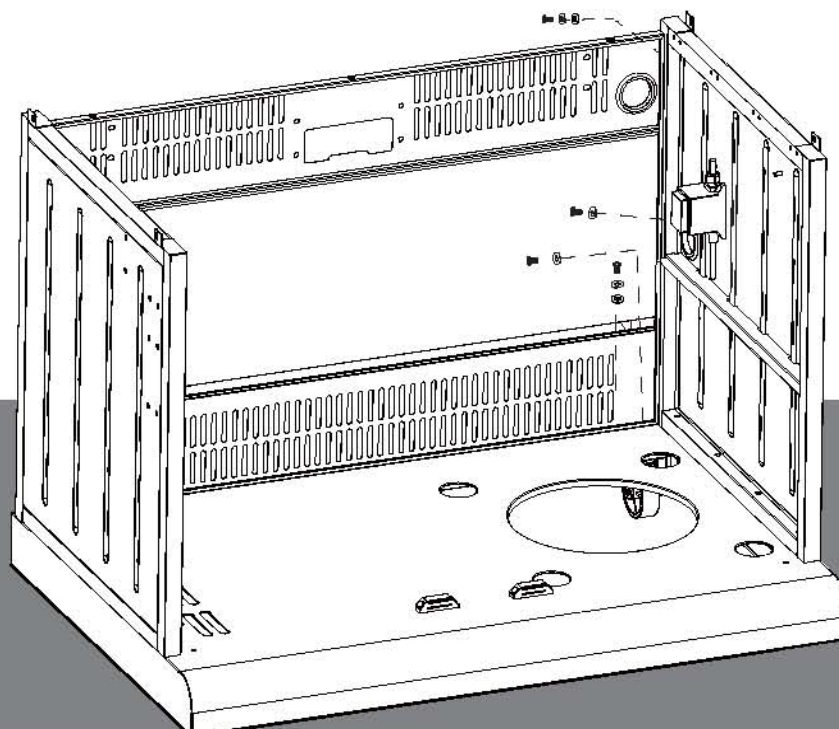

MATADOR

STEP 7

-  2: 5mm (S/S)
-  2: 5mm (S/S)
-  2: 5mm (S/S)

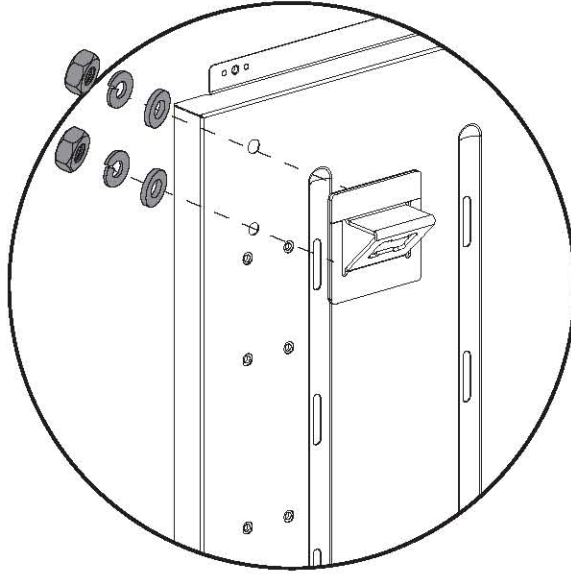

STEP 8

-  11: 5mm x 12mm
-  11: 5mm
-  11: 5mm

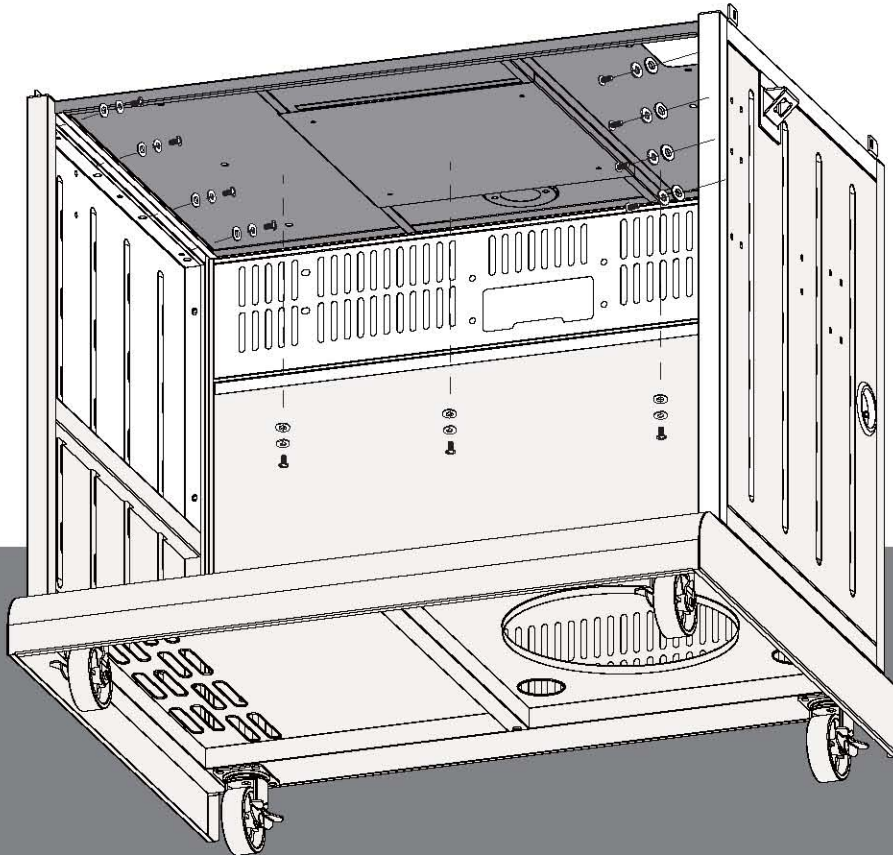

STEP 9

 18: 5mm x 12mm

 16: 5mm

 16: 5mm

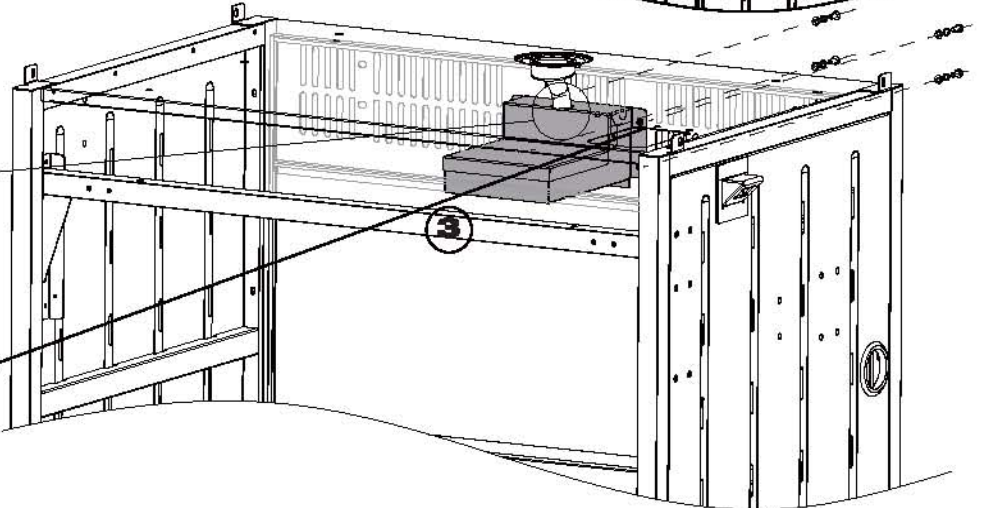
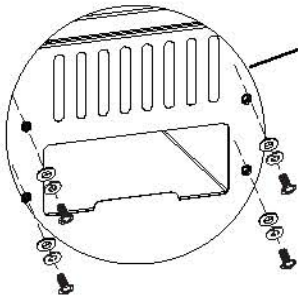
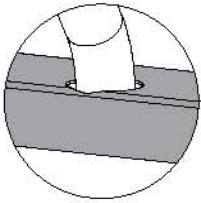
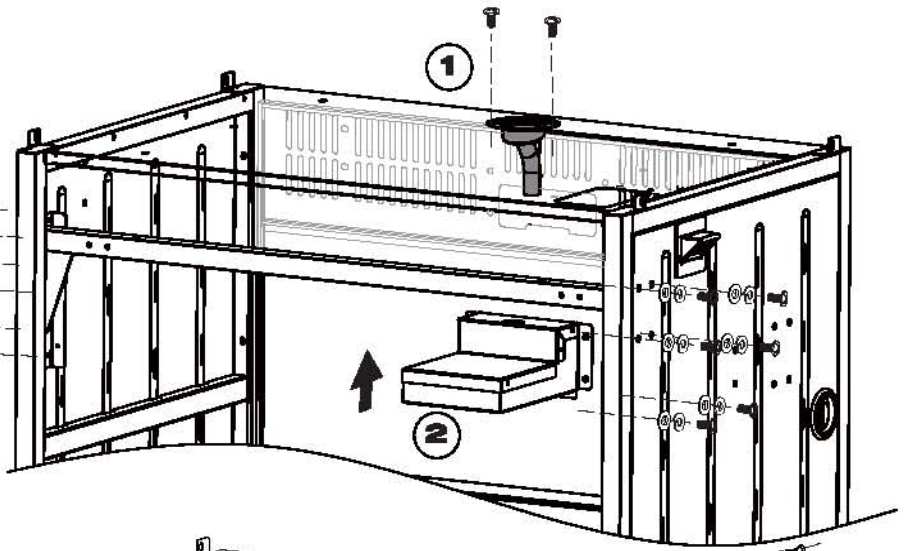
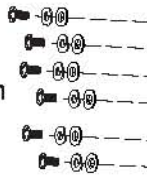

STEP 10

 6: 5mm x 12mm

 6: 5mm

 6: 5mm

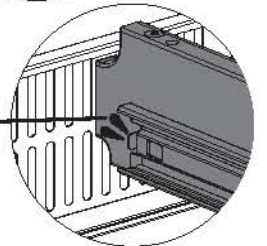
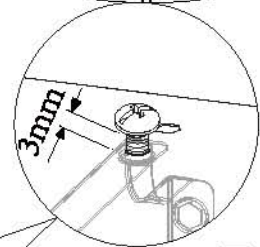
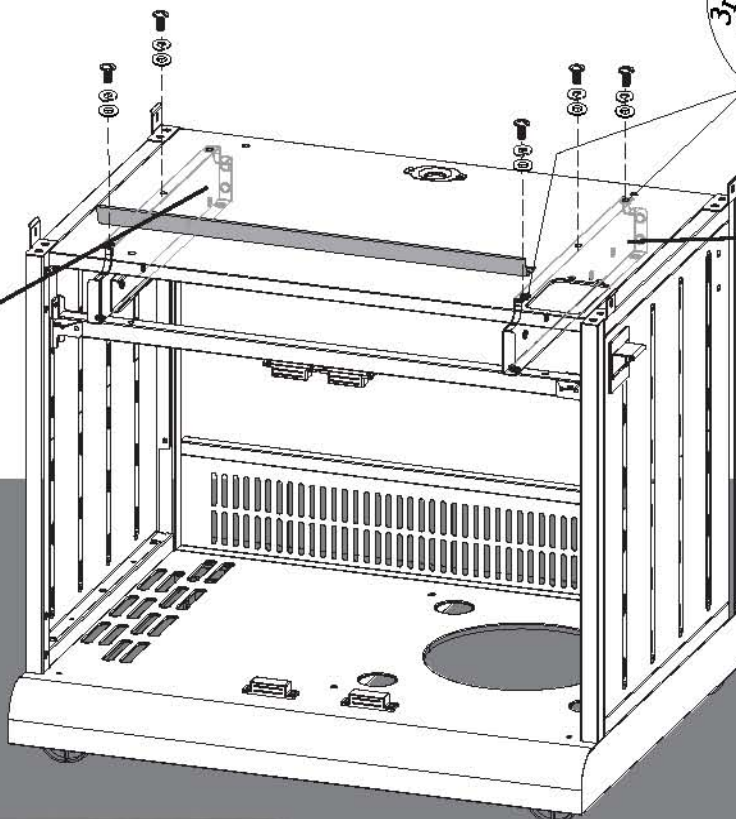
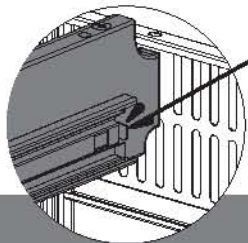

MATADOR

STEP 11

 2: 5mm x 40mm

 2: 5mm

 2: 5mm

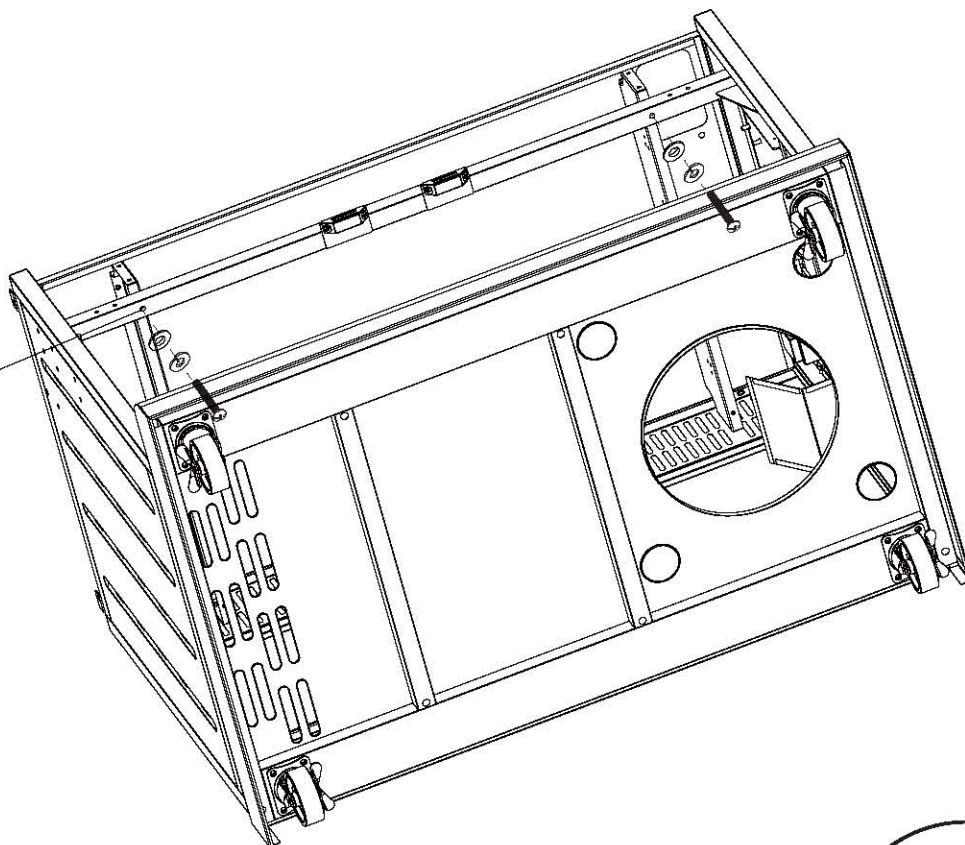
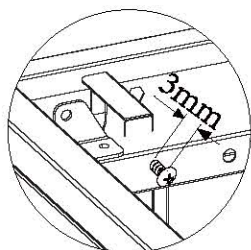

STEP 12

 4: 5mm x 12mm

 4: 5mm

 4: 5mm

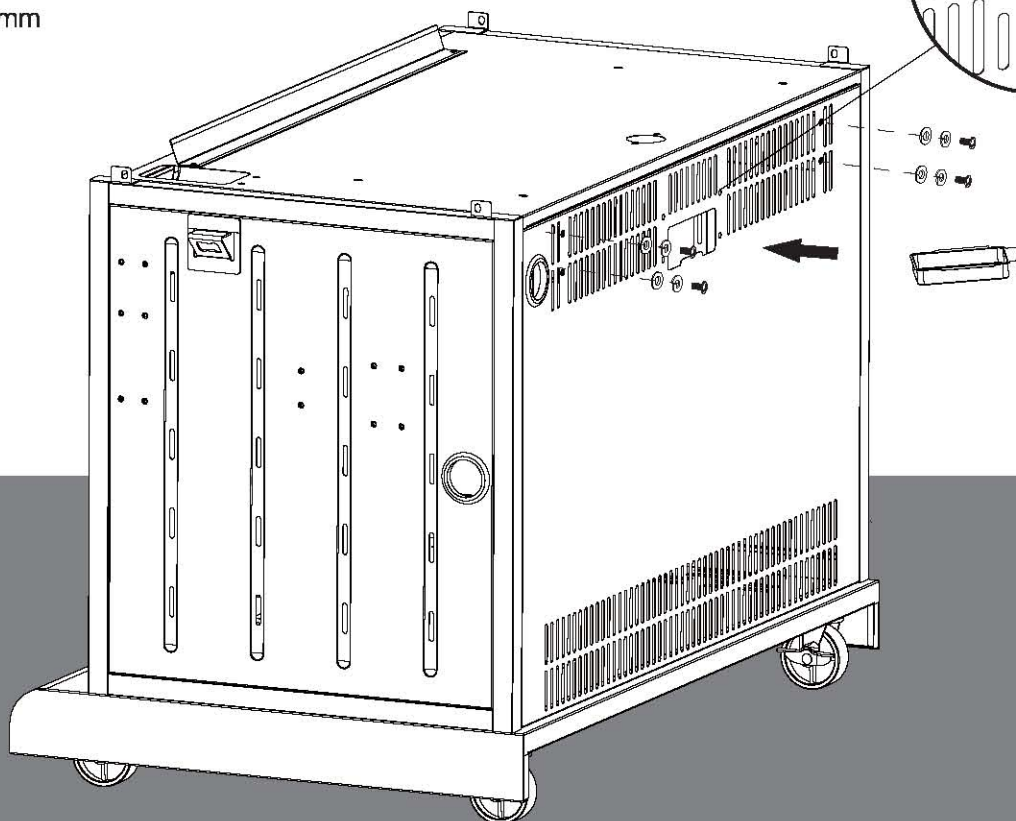
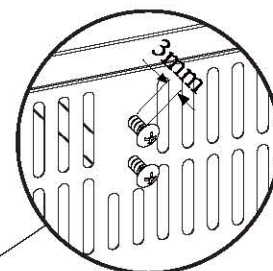

STEP 13

 6: 5mm x 12mm

 6: 5mm

 1:

 1:

 1:

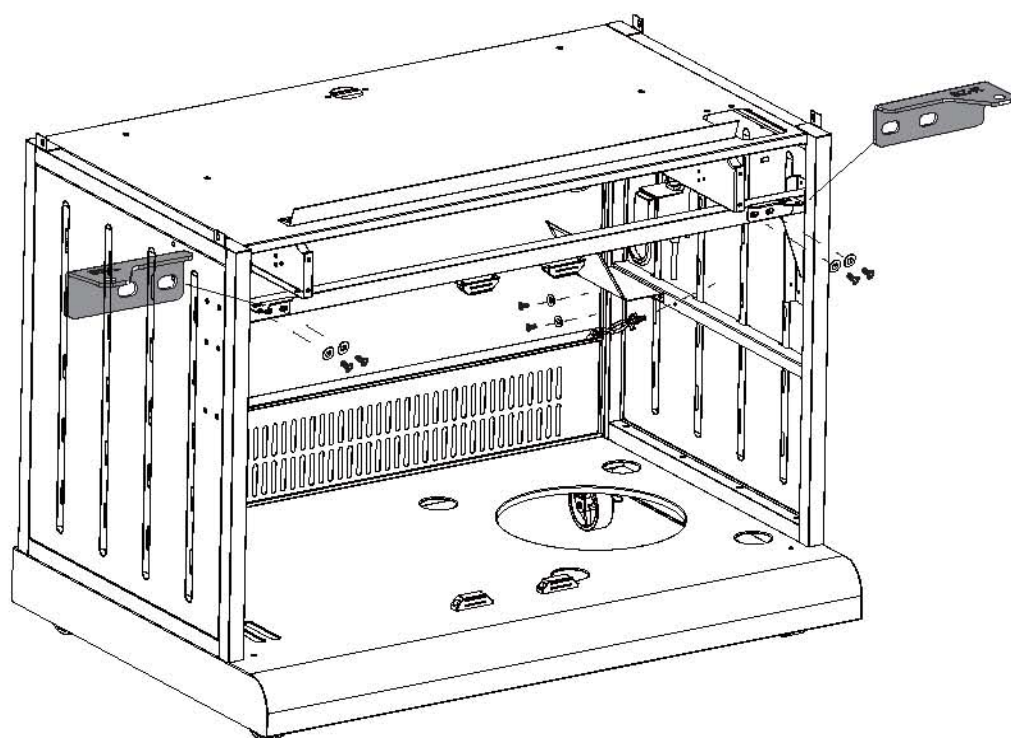

STEP 14

 2: 6mm (S/S)

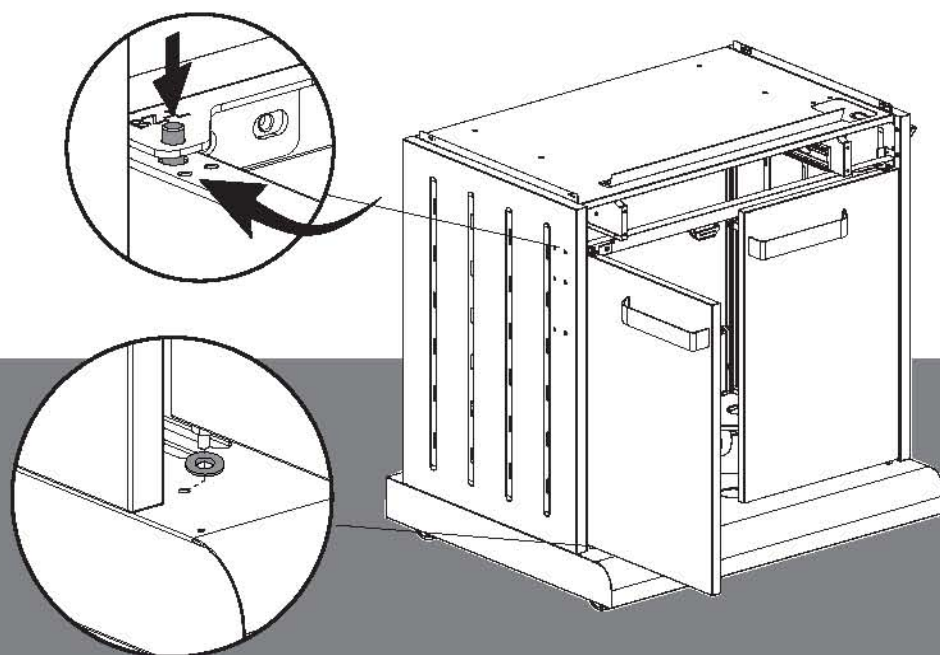

MATADOR

STEP 15

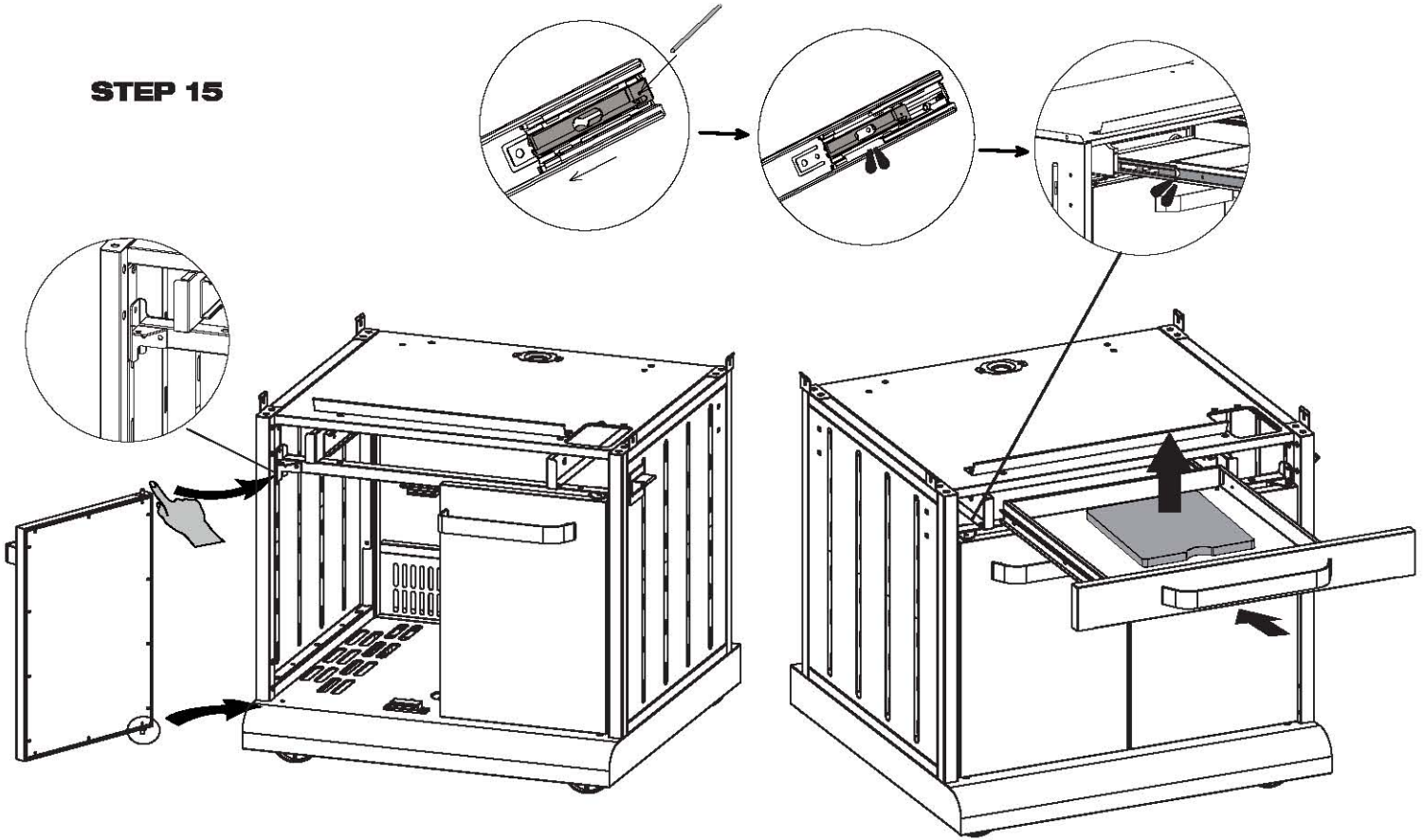

STEP 16

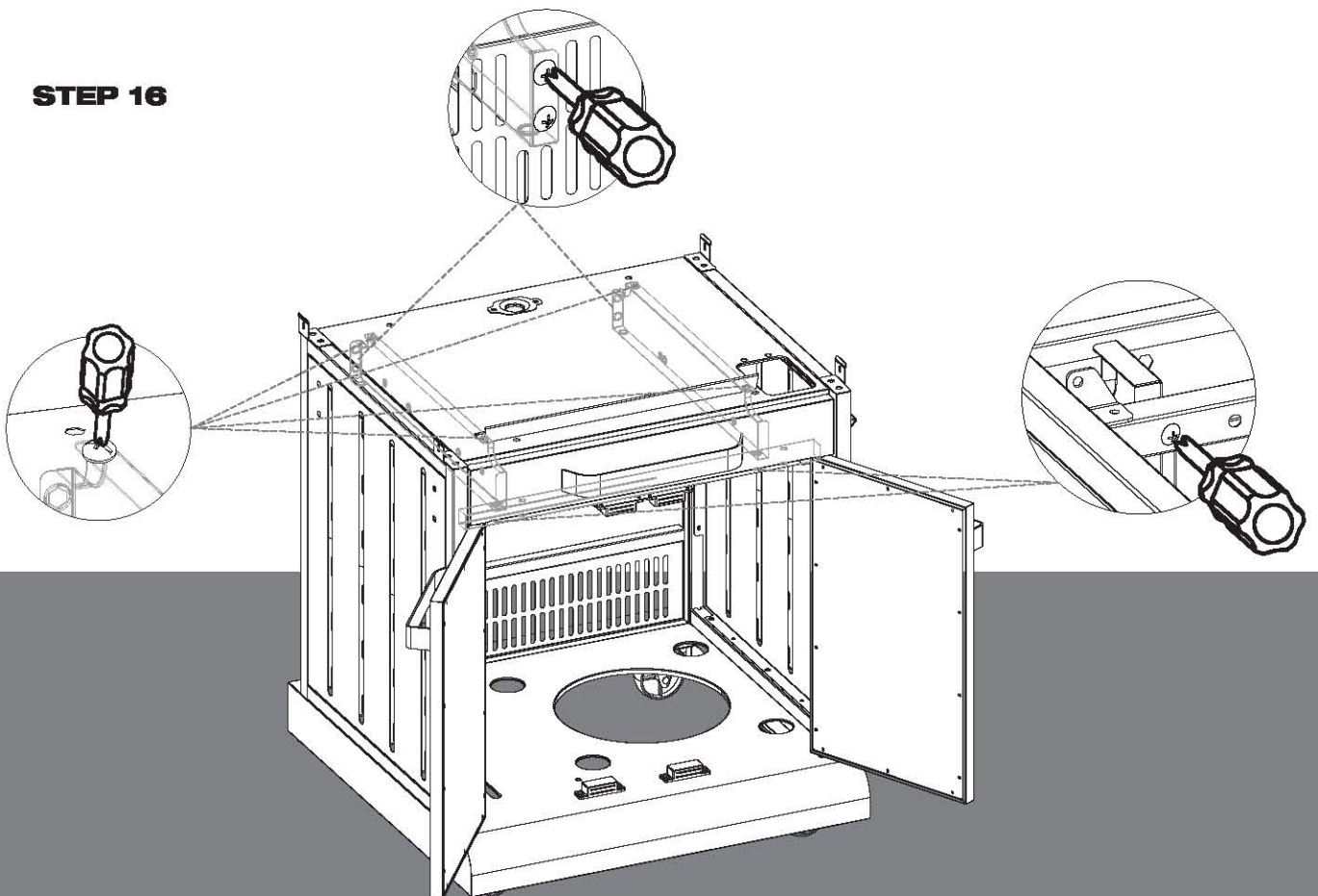

STEP 17

 2: 5mm x 12mm

 X6

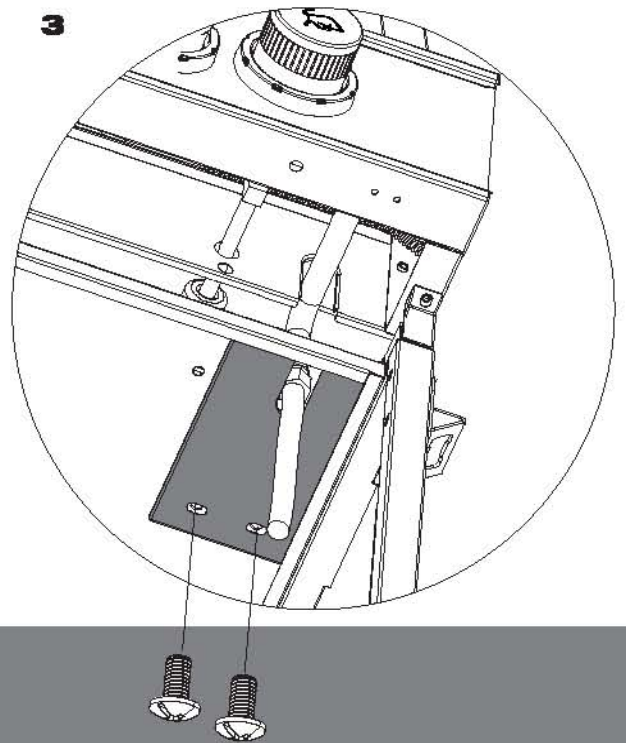
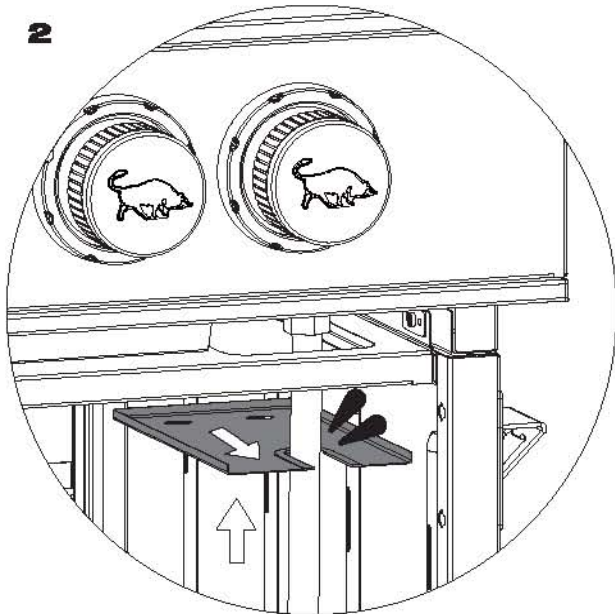
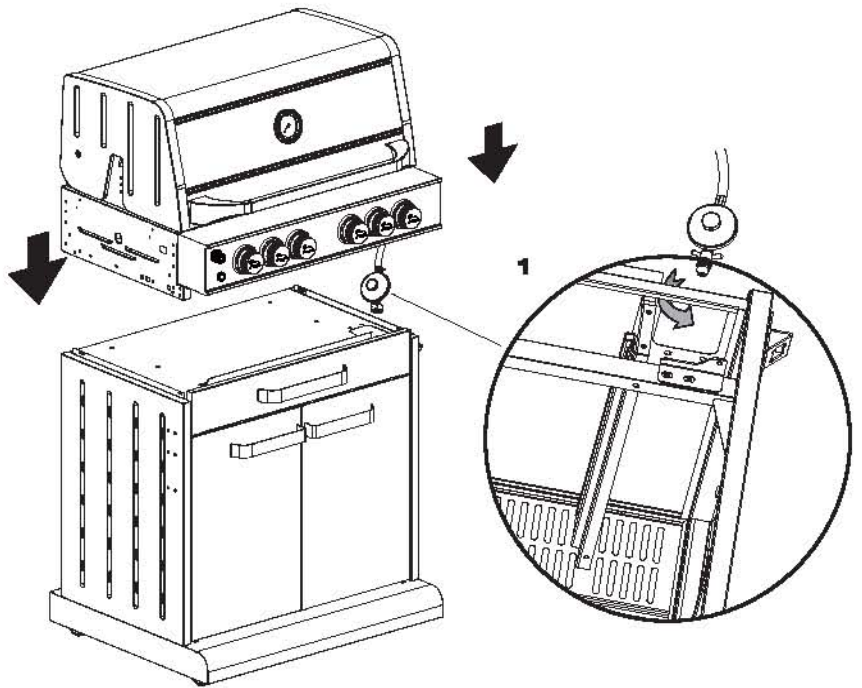
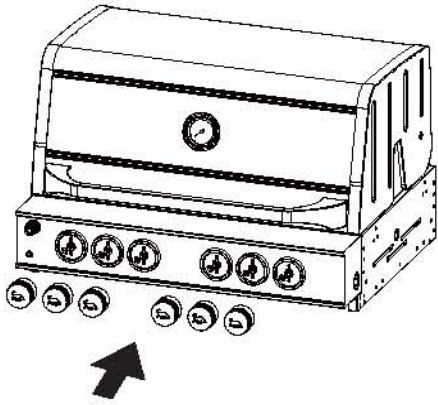

MATADOR.

STEP 18

 4: 5mm x 12mm

 4: 5mm

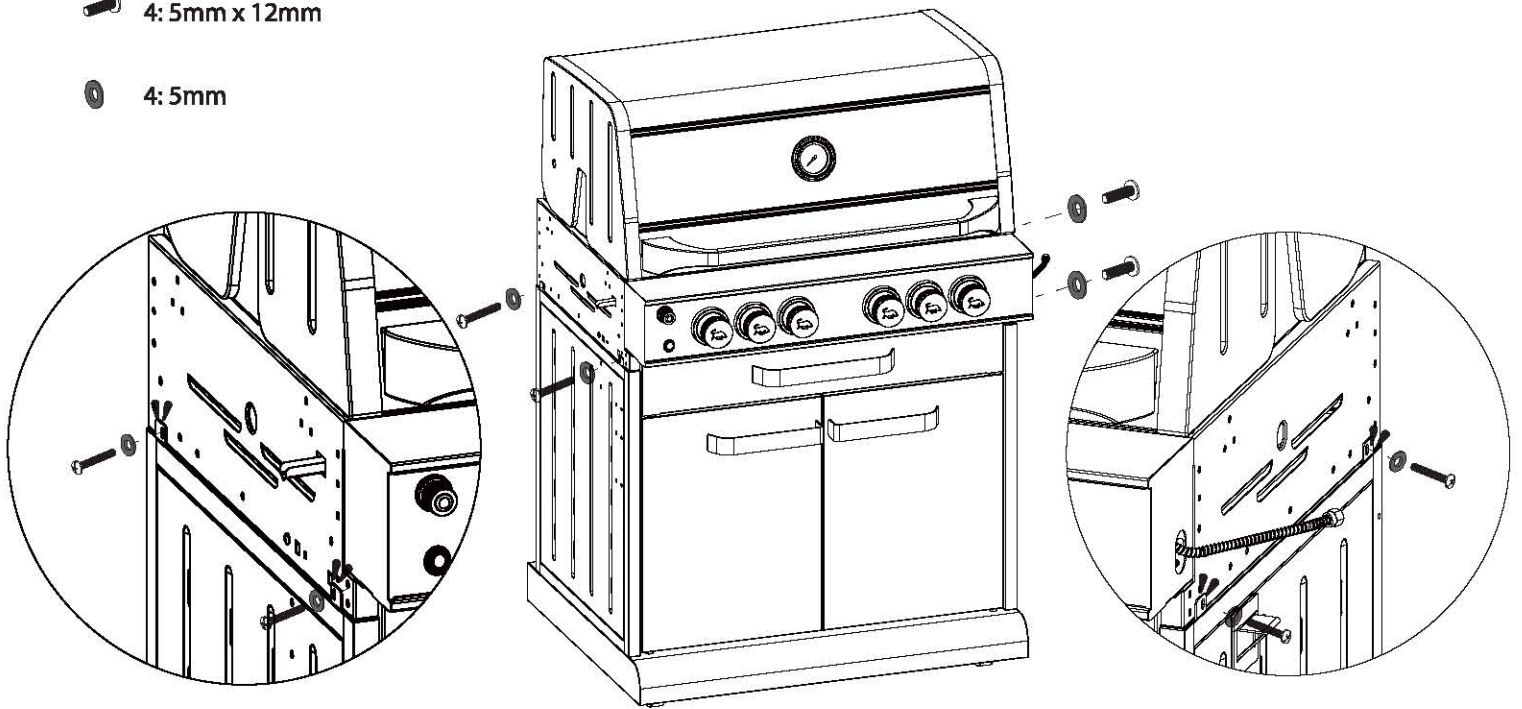

STEP 19

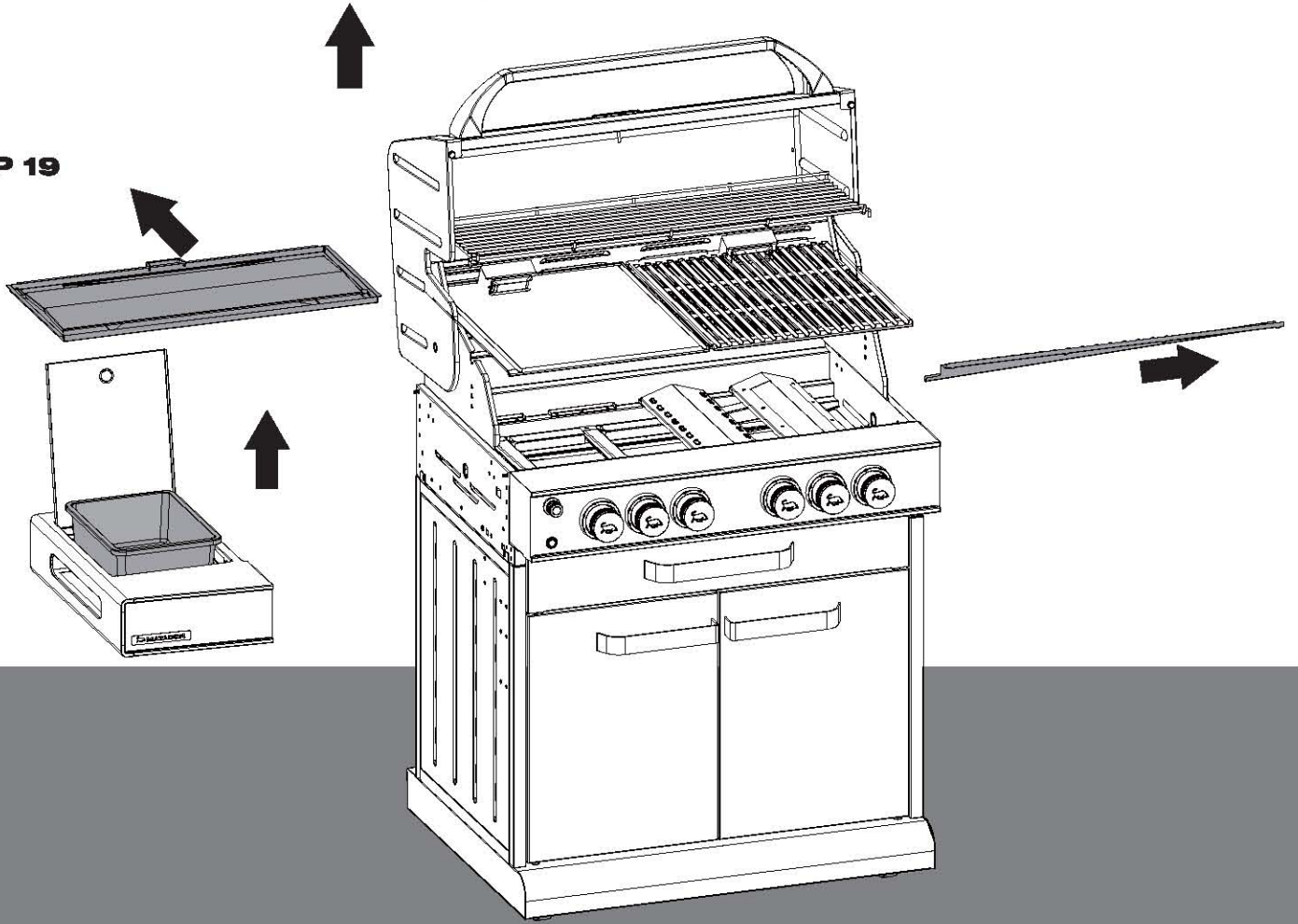

STEP 20

8: 5mm x 12mm

8: 5.5mm

4:

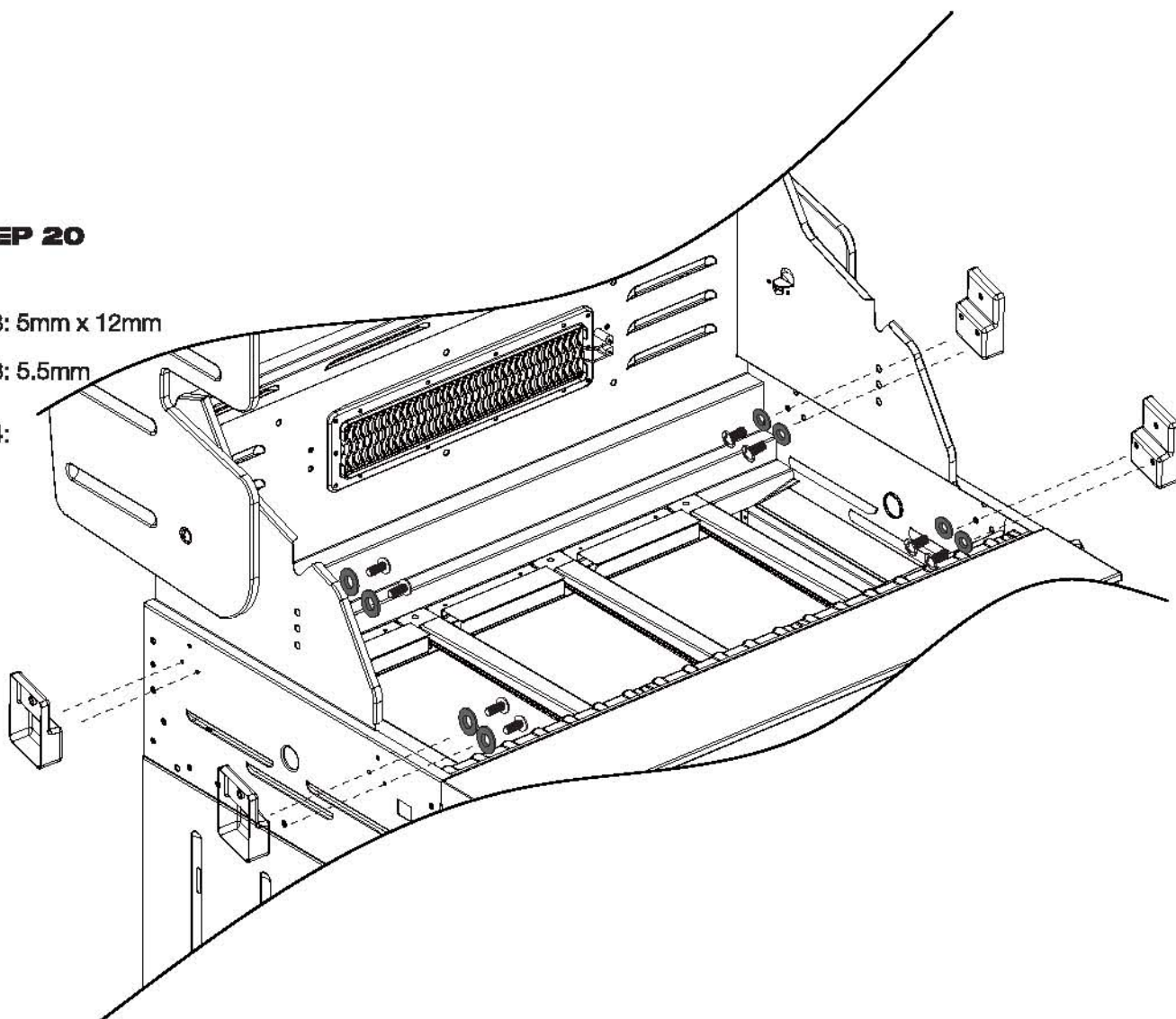

STEP 21

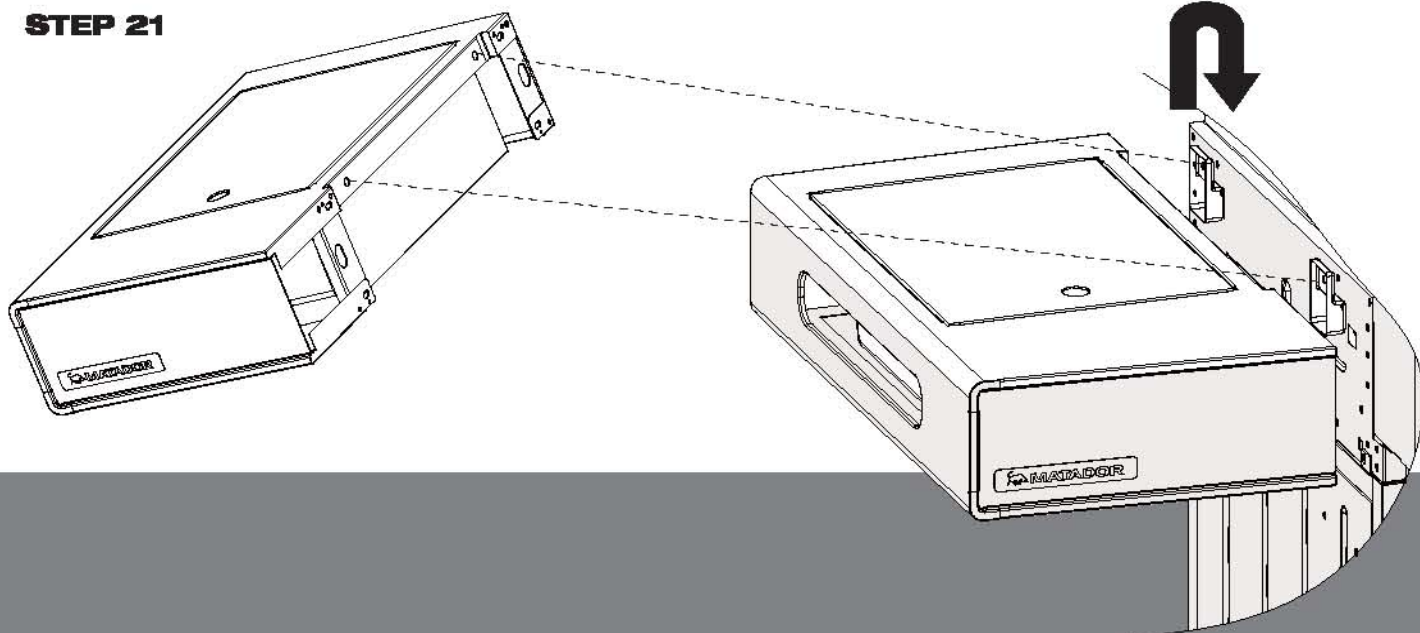

MATADOR

STEP 22

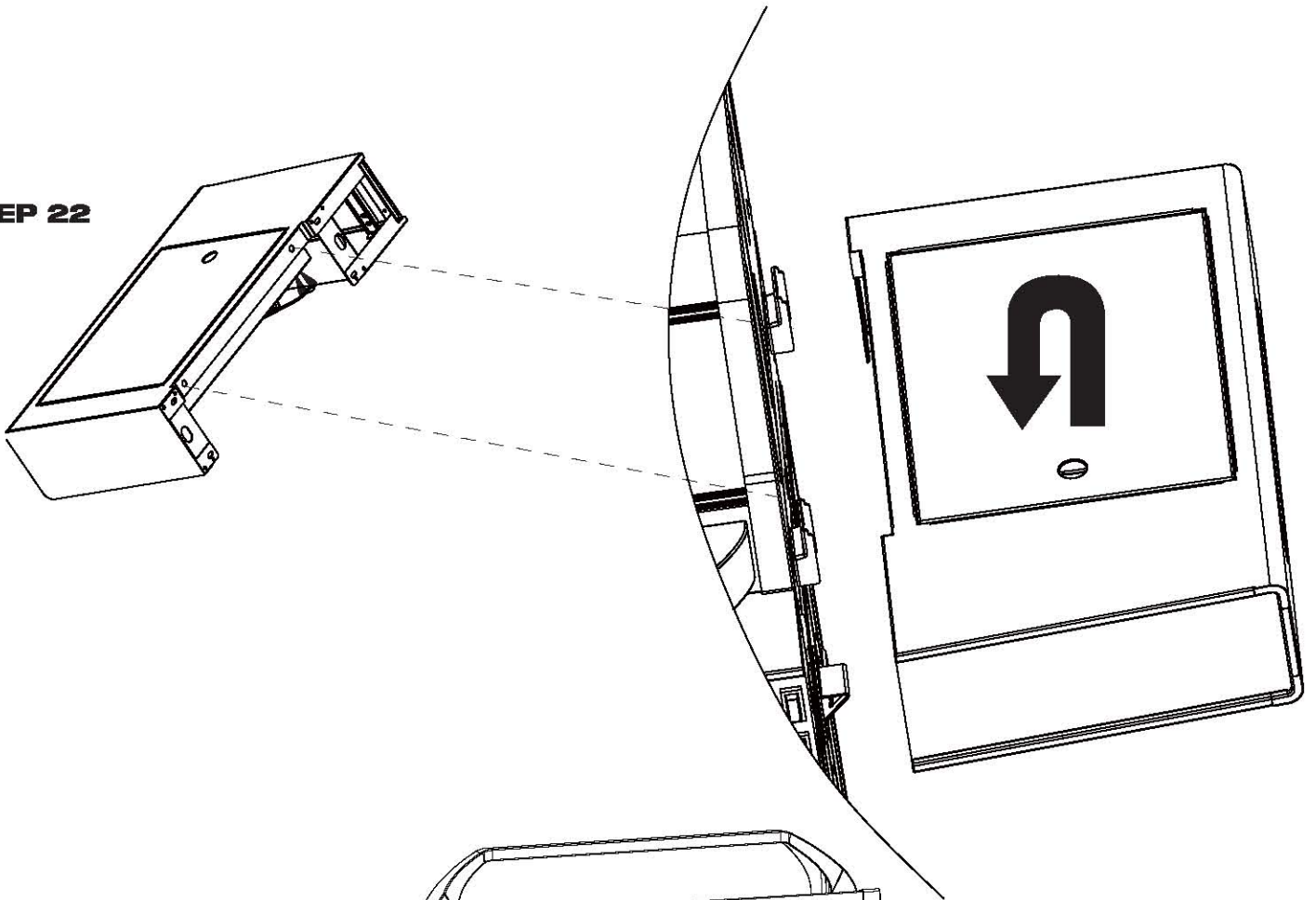

STEP 23

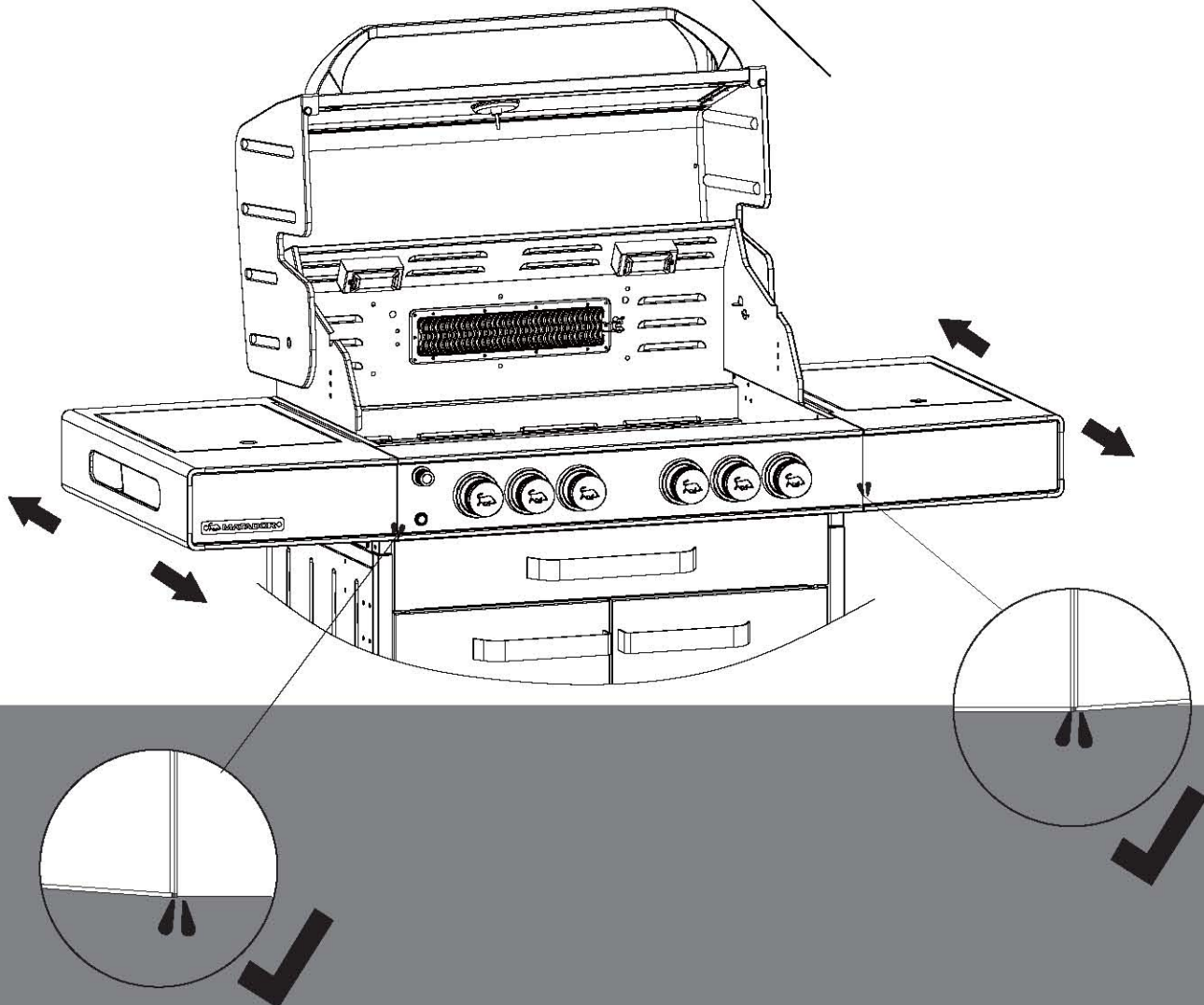

STEP 24

 4: 5mm x 20mm

 4: 5mm x 12mm

 4: 5mm

 4: 5.5mm

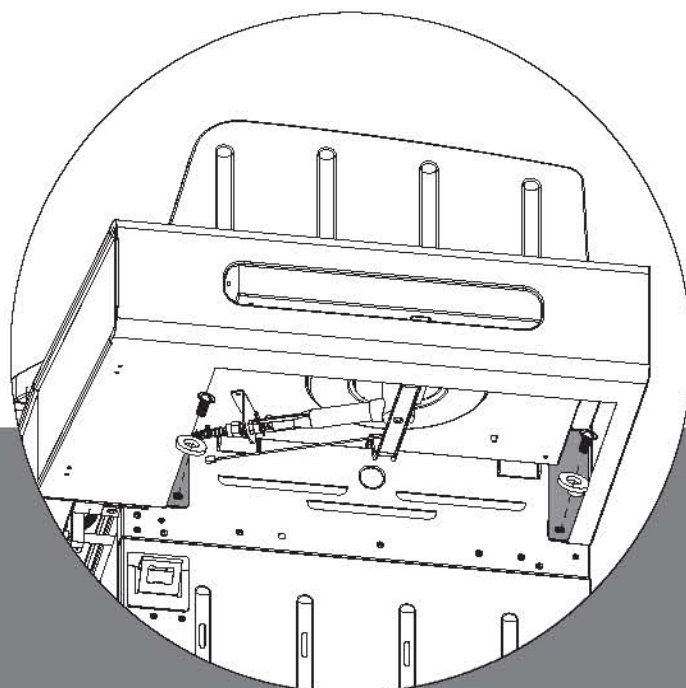
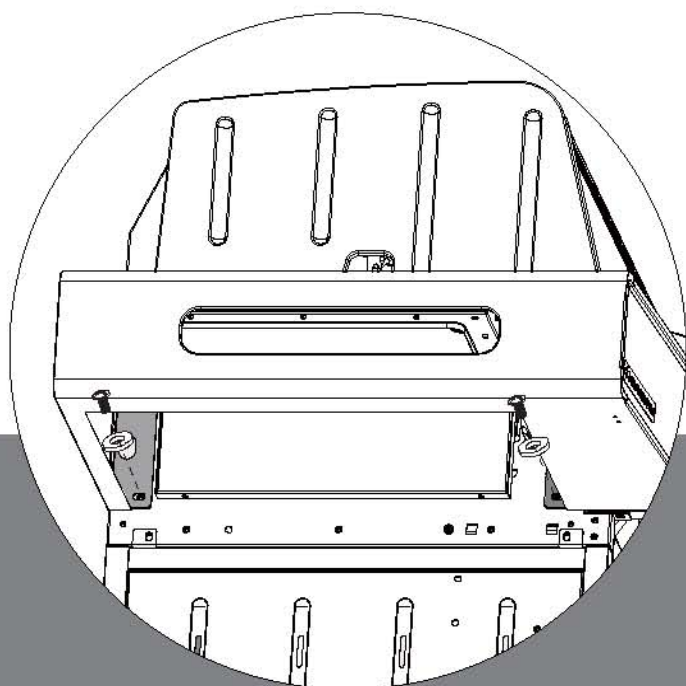
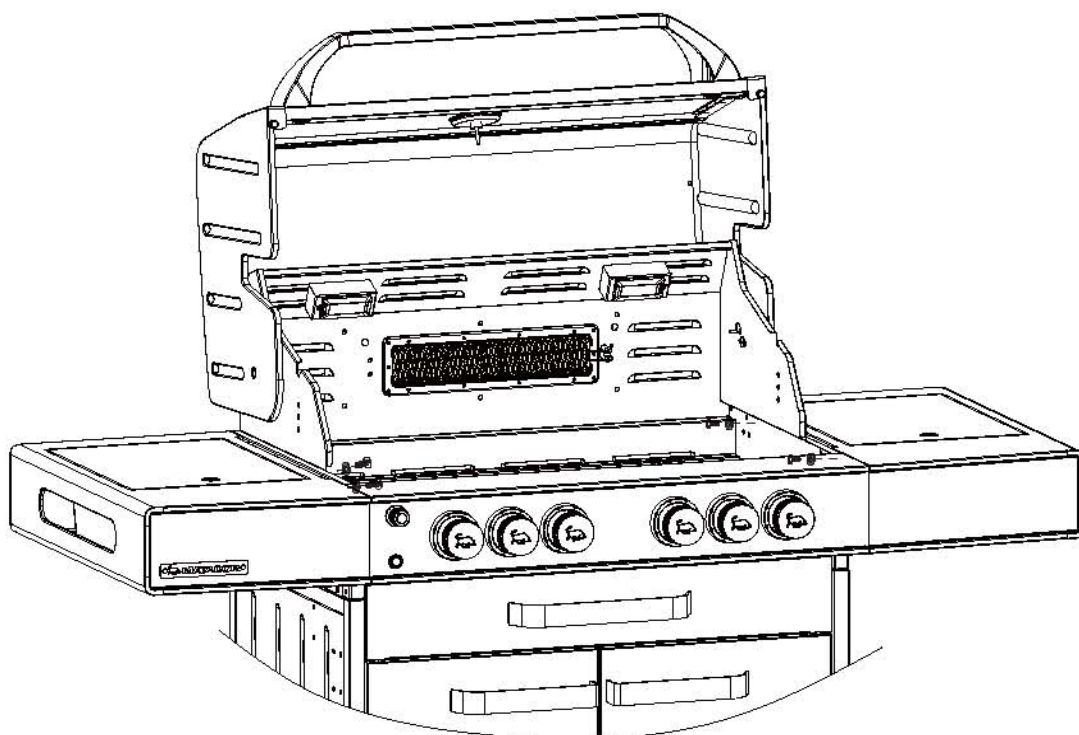

MATADOR

STEP 25

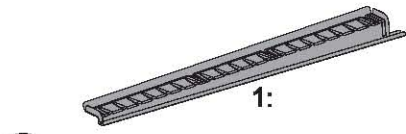

4: 5mm x 12mm

4: 5.5mm

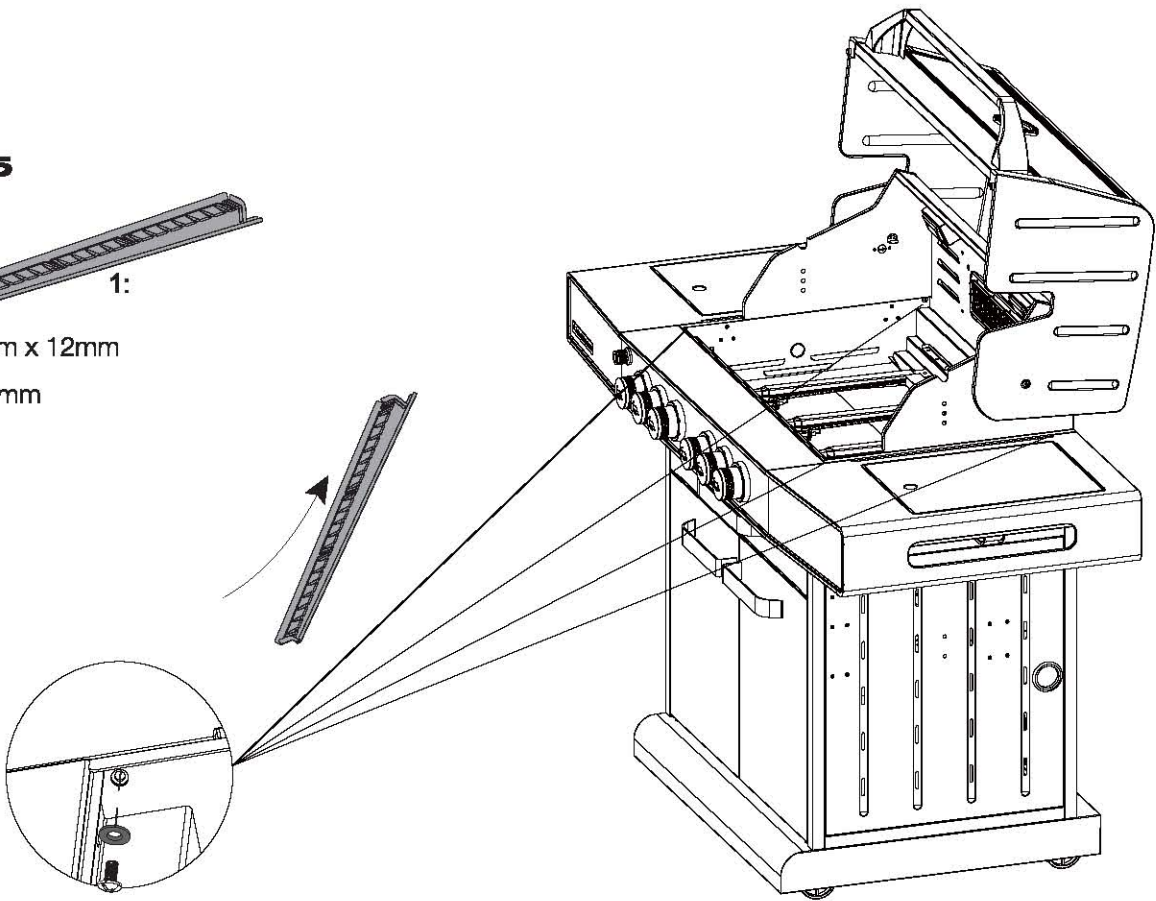

STEP 26

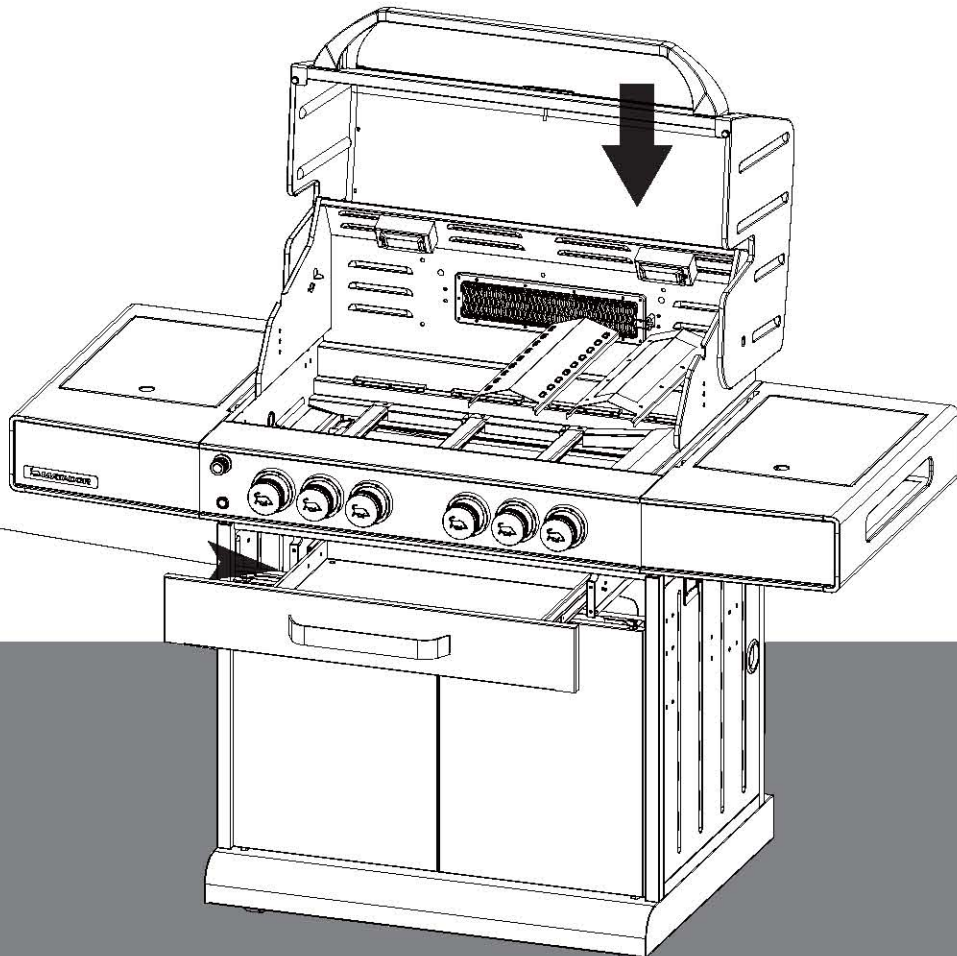

STEP 27

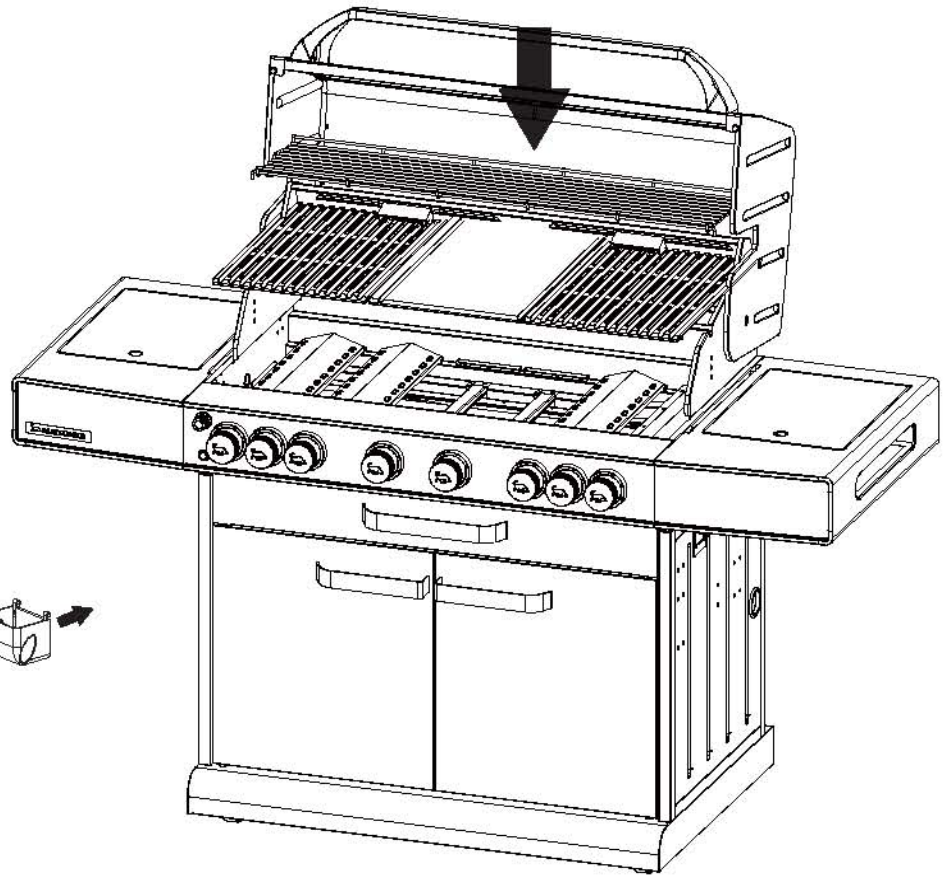
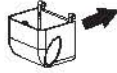
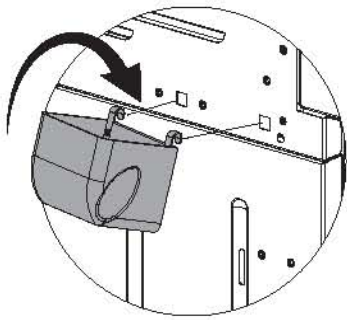
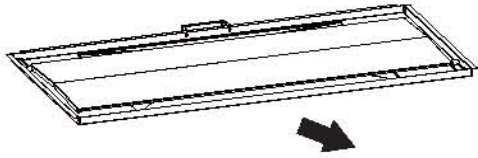

STEP 28

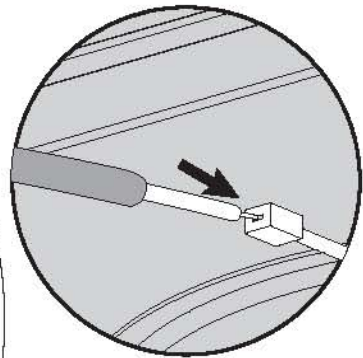
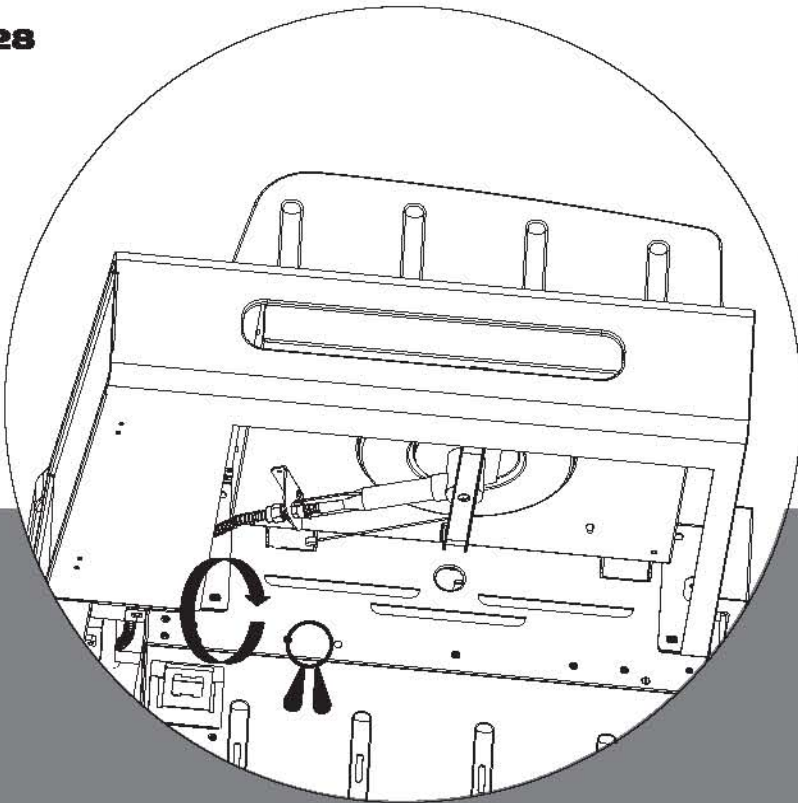

MATADOR

STEP 29

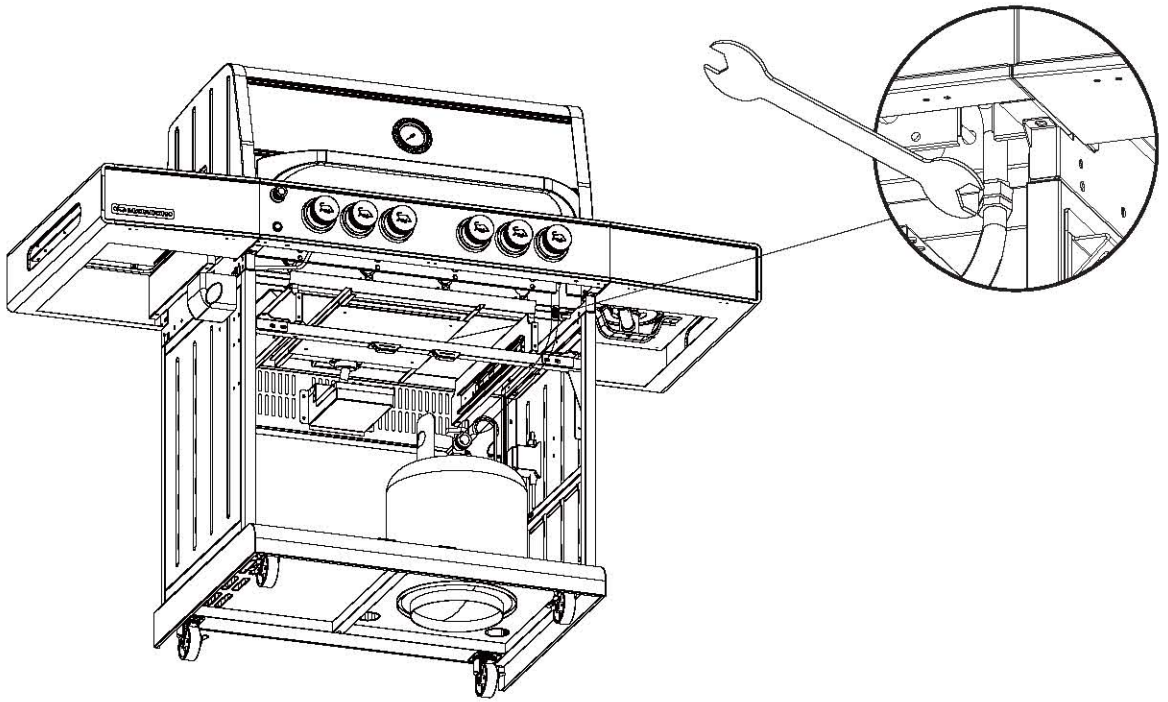

STEP 30

 4:

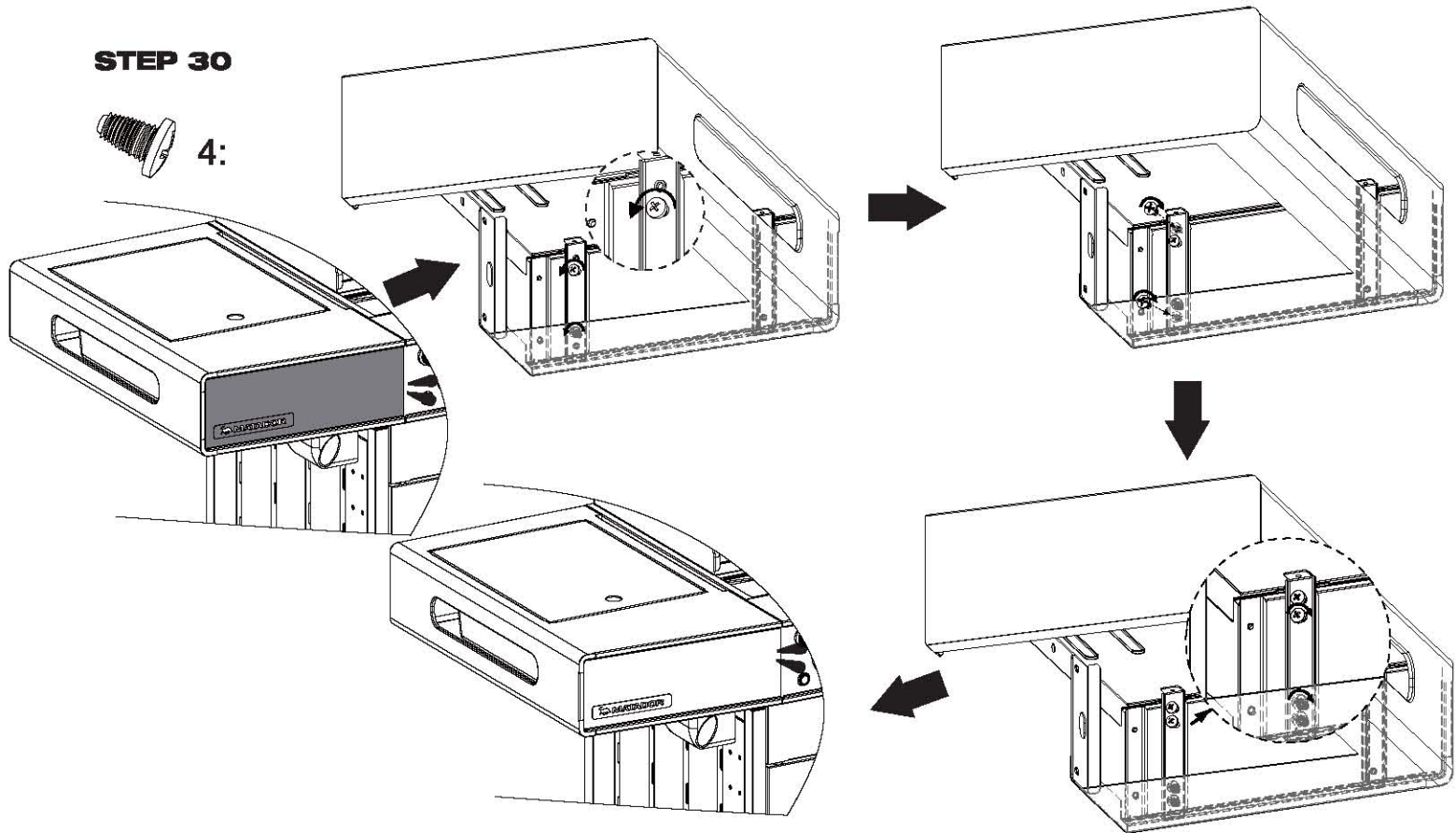

LR6 AA 1.5V

STEP 31

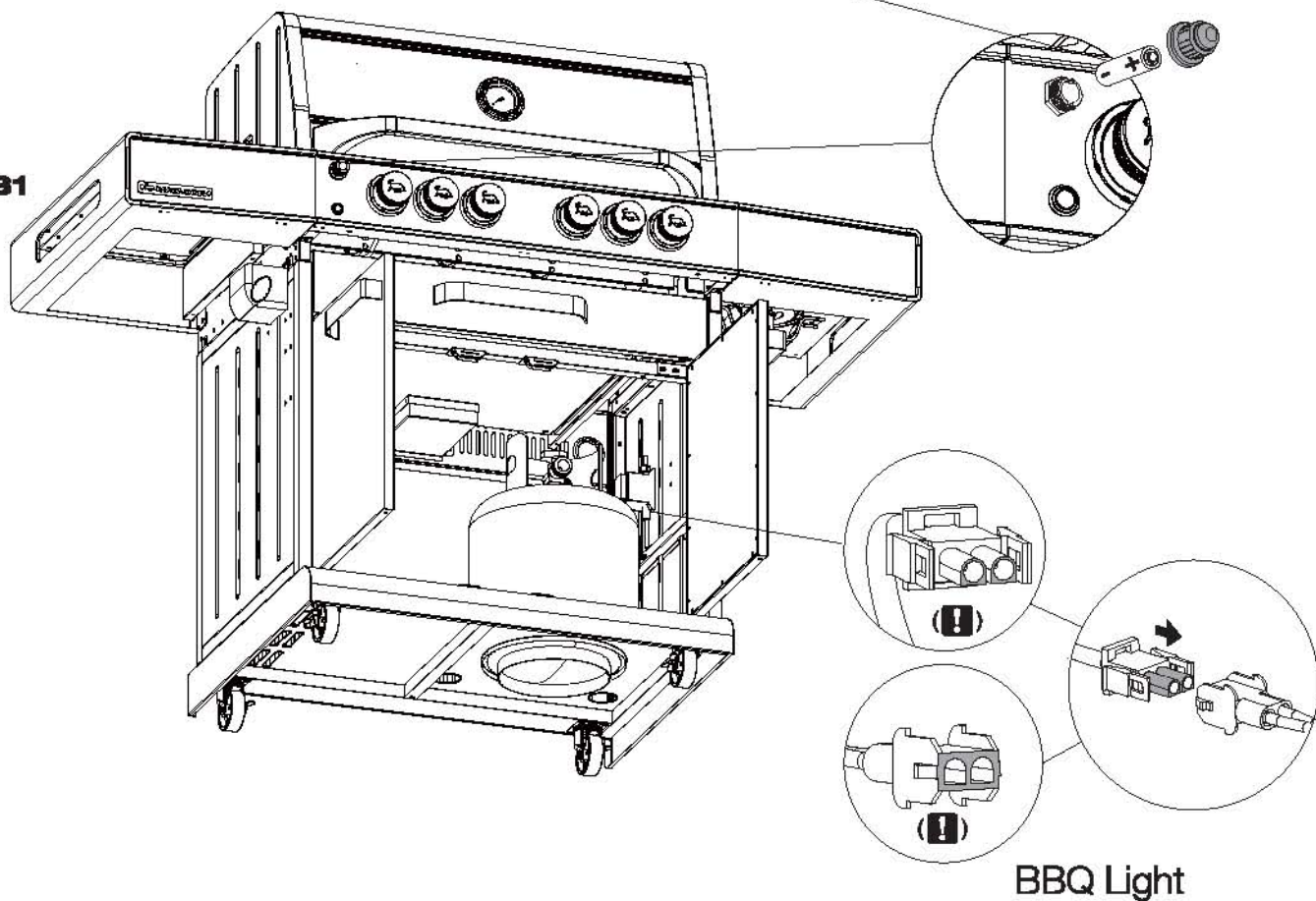

STEP 32

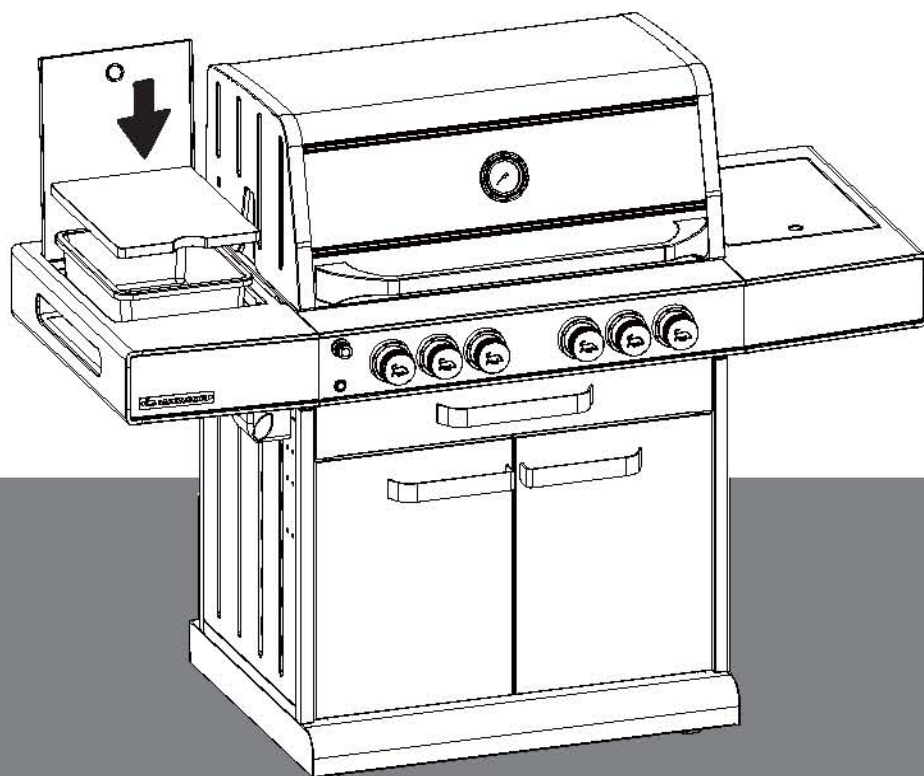

LIST OF SPARE PARTS

For spare parts refer to your store of purchase.

For warranty visit:
www.garthsupport.com

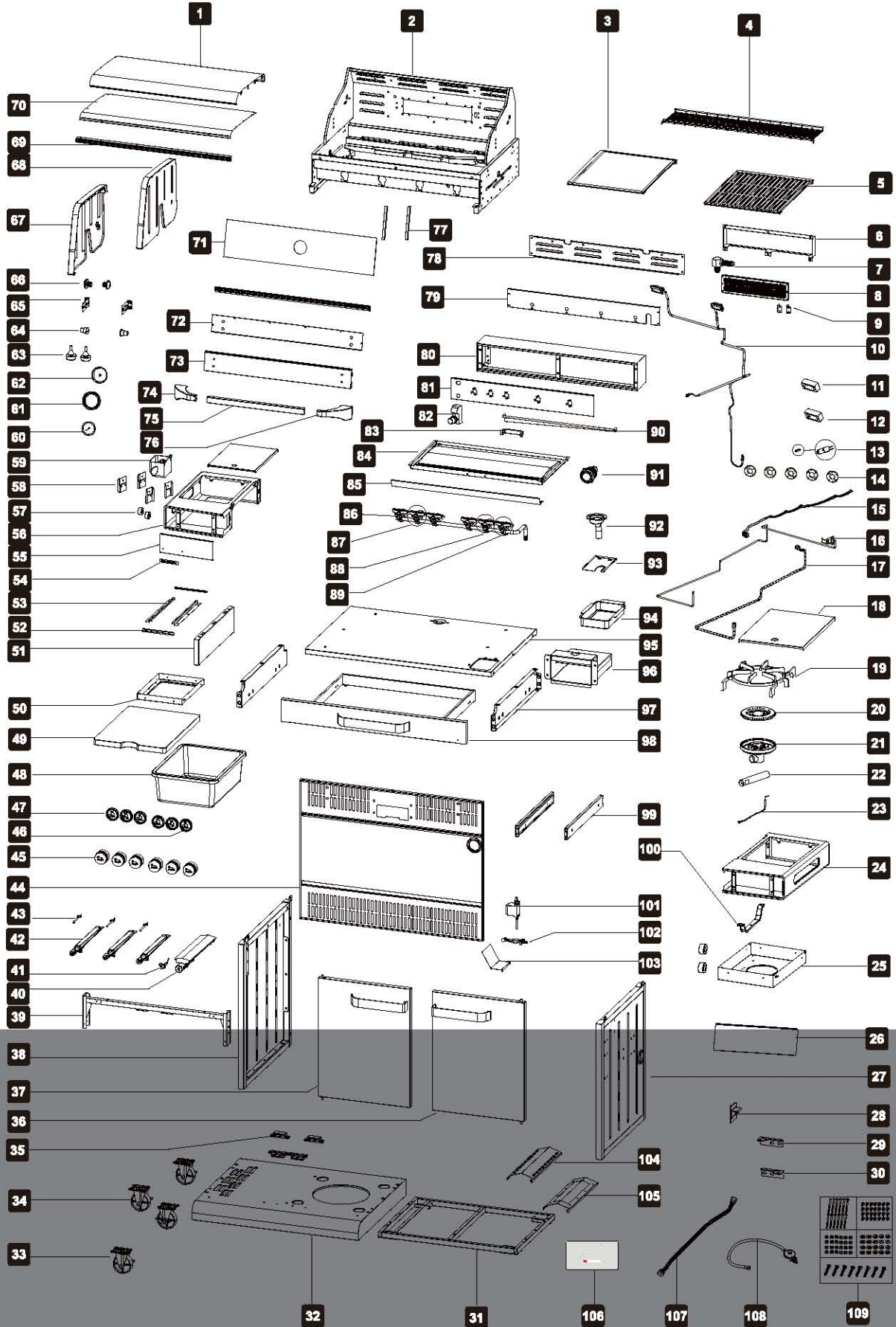

PART NUMBER	PART NAME	SUPPLIER CODE	AVAILABLE OR NOT
1	Hood outer top	RCHD4-0701-09060-085	
2	BBQ frame	RCBQ4-2803-04100-033	
3	Grillsmart hotplate	B03059-M	
4	Warming rack	RCBQ4-0101-01000-033	
5	Grillsmart grill	B03060-M	
6	Rear burner cover	RCBQ0-5101-04060-033	
7	Rear burner injector	B279-15B-H-03	
8	Rear burner	TMA0823	
9	Rear burner injector bracket	RCBQ0-5401-04060-033	
10	BBQ Light set	BQLW-2L	
11	Right BBQ Light Support Plate	B238-B-08	
12	Left BBQ Light Support Plate	B238-B-09	
13	BBQ light Bulb	BQ-BU10W	
14	knob lights	RCBQ0-8803-00000-080	
15	Knob light wire set	RCBQ4-6803-00000-080	
16	Rear Burner Ignition wire	LU1650	
17	Rear Burner S/S Flexible Pipe	FP-160-01	
18	Side Burner Lid	RCTRO-0601-07080-031	
19	Side Burner Trivet	SB-103	
20	Wok burner	TMB003-1	
21	Wok burner base	TMB003-2	
22	Wok burner venturi	TMB003-4	
23	Wok burner Ignition wire	Q3561	
24	side burner shelf	RCTRO-0303-07080-031	
25	Side burner bowl	RCTRO-4901-07080-031	
26	Right side shelf decoration part	RCTRO-0501-09080-085	
27	Cabinet right side panel	RCTRO-1801-00000-031	
28	Bottle opener	BO-003	
29	Left door support bracket	RCTRO-2401-07080-031	
30	Right door support bracket	RCTRO-2501-07080-031	
31	Cabinet bottom strengthen frame	RCTR4-8801-00000-031	
32	Cabinet bottom panel	RCTR4-1901-07080-031	
33	Lockable castor	Vm110416	
34	Unlockable castor	VM140408	
35	Cabinet magnet	MG-10	
36	Right door	RCTR4-2301-09080-085	
37	Left door	RCTR4-2201-09080-085	
38	Cabinet left side panel	RCTRO-1701-00000-031	
39	Cabinet front cross bar	RCTR4-1501-01080-031	
40	Sear Burner	B03094-M	
41	Sear burner Ignition pin	Q3562	
42	Main Burner	BR160122	
43	Main burner ignition pin	Q3558	
44	Cabinet back panel	RCTR4-1601-07060-031	
45	Control knob	BKNB-207A	
46	Sear burner Control knob bezel	BS170329	
47	Control knob bezel	BS170331	
48	Ice bucket	BCK-170414	
49	Chopping board	RCTRO-16201-13000-103	
50	Ice bucket support	RCTRO-16401-07080-031	
51	Ice bucket heat shield panel	RCTRO-16301-05060-080	
52	Ice bucket holder-A	RCTRO-16501-07080-031	
53	Ice bucket holder-B	RCTRO-16601-07080-031	
54	badge	BA-B2015V2	
55	Left side shelf decoration part	RCTRO-0401-09060-085	
56	Left side shelf	RCTRO-0103-07080-031	
57	Phenolic spacer	RCTRO-3401-14000-080	
58	Side Shelf Attaching Plate	RCTRO-15801-07200-074	
59	Phenolic Oil cup	FC-024	
60	Temperature gauge	N160307	



MATADOR

PART NUMBER	PART NAME	SUPPLIER CODE	AVAILABLE OR NOT
61	Temperature gauge bezel	BS131016-B	
62	Temperature gauge bowl	TG-B05	
63	Rubber bumper	K2224	
64	Hood hinge pin	RCHD0-0101-01000-077	
65	Hood hinge holder	RCHD0-0301-04000-077	
66	Hood hinge serew	RCHD0-0201-01000-077	
67	Hood left end	RCHD0-0501-03000-031	
68	Hood right end	RCHD0-0601-03000-031	
69	Glass support strip	RCHD4-1501-11000-080	
70	Hood second skin top	RCHD4-0801-09060-085	
71	hood glass	GB279	
72	Hood second skin bottom	RCHD4-1001-07060-084	
73	Hood outer bottom	RCHD4-0901-09060-085	
74	Left hood handle base	RCHD0-1201-03000-031	
75	Hood handle	RCHD4-1101-01000-031	
76	Right hood handle base	RCHD0-1301-03000-031	
77	Glass seal	RCHD0-1601-02000-080	
78	BBQ frame back cover	RCBQ4-3301-07060-104	
79	Fascia heat shield panel	RCBQ4-2401-05050-080	
80	BBQ front decoration part	RCBQ4-2201-00000-031	
81	Fascia	RCBQ4-2301-09080-085	
82	Ignition box	PI-PT01	
83	Fat tray handle	BH-JD4	
84	Fat tray	RCBQ4-2001-10060-080	
85	Cabinet top panel heat shield	RCTR4-0901-05050-080	
86	Main burner gas valve	GC-077A	
87	Rear burner gas valve	GC-081A	
88	Side burner gas valve	N0056A	
89	Sear burner gas valve	GC-085A	
90	Oil channel	RCBQ4-1301-10050-080	
91	Light Switch	RCBQ0-8001-10000-080	
92	Fat tray channel	RCTR0-7801-02100-074	
93	Regulator cover	RCTR0-8401-05050-080	
94	Oil cup	RCTR0-8001-05050-080	
95	Cabinet top panel	RCTR4-1001-07060-031	
96	Oil cup shield	RCTR0-7901-05050-080	
97	Drawer holder	RCTR0-1401-07100-074	
98	Drawer	RCTR4-1101-09000-085	
99	Drawer slide	RCTR0-1301-00000-080	
100	Side Burner Under Strut	RCTR0-3001-07080-074	
101	Transformer	RCTR0-3601-00000-080	
102	Wire clip	RCTR0-3701-13000-080	
103	Transformer cabel separation panel	RCTR0-3801-07060-031	
104	V shape flame tamer	RCBQ0-0501-10100-080	
105	Sear burner flame tamer	RCBQ0-7601-10100-080	
106	Drawer mat	MAT-493	
107	Side Burner S/S Flexible Pipe	FP-041-01	
108	Hose and Regulator	RC008002	
109	Bolt pack	BP-B279-17	

MATADOR WARRANTY

Thank you for purchasing one of our quality Matador BBQs.

YOUR MATADOR BBQ IS COVERED AGAINST DEFECTS FOR A PERIOD OF 5 YEARS FOR PARTS AND LABOUR, REPAIR OR REPLACEMENT. THIS WARRANTY EXCLUDES SURFACE RUST AND DAMAGE CAUSED BY ABUSE OR NEGLIGENCE.

CONDITIONS OF THE WARRANTY

- The appliance must be operated and maintained in accordance with the instructions supplied in the operating manual.
- Any repair does not extend the warranty period.
- Any parts other than original Matador parts will void this warranty.

Installation Conditions

- All installations must conform to the applicable Gas, Electrical and Building standards as laid down by the local codes for state or region.
- If the appliance is changed to natural gas (if applicable), it must be converted and installed by a licensed gas fitter.

FOR WARRANTY CLAIMS

Garth Australia Pty Ltd.
52 Boundary Road
Sunshine West
Victoria 3020
AUSTRALIA

Garth Support website: www.garthsupport.com
or call: 1800 427 841
email: service@garth.com.au

The warranty for New Zealand is given by
Bunnings NZ Ltd
PO Box 14436,
Panmure, Auckland, 1741
NEW ZEALAND

Tel: 09-9782200
Fax: 09-9782222
Email: marketing@bunnings.co.nz

Any claim under this warranty must be made within 5 years of the date of purchase of the product.

Proof of purchase must be presented.

For Australian Customers

To make a claim under the warranty please contact Garth support website: www.garthsupport.com or return the product (with proof of purchase) to any Bunnings store. (see: www.bunnings.com.au for store locations)

Garth Australia bears reasonable, direct expenses of claiming under the warranty.

The warranty covers manufacturer defects in materials, workmanship and finish under normal use.

This warranty is provided in addition to other rights and remedies you may have under law: our goods come with guarantees which cannot be excluded under the Australian Consumer Law. You are entitled to replacement or refund for a major failure and to compensation for other reasonably foreseeable loss or damage. You are also entitled to have the goods repaired or replaced if the goods fail to be of acceptable quality and the failure does not amount to a major failure.

The warranty excludes damage resulting from product misuse or product neglect. The warranty covers domestic use only and does not apply to commercial applications

For New Zealand Customers

To make a claim under the warranty, take the product (with proof of purchase) to any Bunnings store (see www.bunnings.co.nz for store locations).

Bunnings NZ Ltd bears reasonable, direct expenses of claiming under the warranty. You may submit details and proof to our store for consideration.

The warranty covers manufacturer defects in material, workmanship and finish under normal use.

The warranty is provided in addition to other rights and remedies you may have under law: our goods come with guarantees which cannot be excluded under the Consumer Guarantees Act 1993 (NZ). You are entitled to replacement or refund for a major failure and to compensation for other reasonably foreseeable loss or damage. You are also entitled to have the goods repaired or replaced if the goods fail to be of acceptable quality and the failure does not amount to a major failure.

The warranty excludes damage resulting from product misuse or product neglect. The warranty covers domestic use only and does not apply to commercial applications.

Goods presented for repair may be replaced by refurbished goods of the same type rather than being repaired. Refurbished parts may be used to repair the goods.



MATADOR

WHAT IS NOT COVERED IN THE WARRANTY

- Removal or re-installation costs. This warranty does not cover costs for transit, nor in home service.
- Liability will only be accepted for loss or damage during transit if at the time the product was being transported by Bunnings or a Bunnings approved contractor.
- Lack of maintenance, abuse, neglect, misuse, accidental or improper installation of this appliance.
- Scratches, dents, corrosion or discoloration caused by heat, abrasive chemical cleaners or chipping of porcelain enamel parts.
- Corrosion or damage caused by exposure to the elements such as insects, weather, hail or grease and fat fires.
- Rusting of cast iron plates, grills and burners.
- Cleaning and wear and tear; service calls of this nature are chargeable.
- Commercial use of the product.
- Unauthorized repairs or modifications during the warranty period.
- Glass breakage due to misuse or overheating
- Consumable items, example - batteries.

RECORD THE FOLLOWING INFORMATION

Attach the copy of the purchase receipt here:

Date of Purchase

Purchased From

Location

Model Name and Number

Serial Number

Receipt Number

Note: The serial number is located either on the outside of the packing carton or outside or inside the appliance.

FOR TECHNICAL ASSISTANCE

For Australia customers if you experience any technical issues with your Matador BBQ, in the first instance review the instruction manual or contact the warranty service agent below.

For New Zealand customers if you experience any technical issues with your Matador BBQ, in the first instance review the instruction manual or contact your local Bunnings warehouse.

FOR SPARE PARTS

Call your local Bunnings warehouse and ask them to order a part for you. You should provide the following information.

Model of BBQ

Year of purchase

Name of warranty service
company above

Part that requires replacement
(refer to the list of spare parts in the
instruction manual)



Visit www.matadorbbqs.com.au

For technical and warranty support call

1800 427 841 (Aus)

0800 357 050 (NZ)

Your purchase receipt will be required for warranty claims.

For spare parts contact your local Bunnings Warehouse