



MATADOR™



Before using the BBQ, remove any packaging material within and around the BBQ supplied for protection during transit.

ARTISTE 2

2 BURNER BBQ WITH HOOD AND CABINET

Retain manual for future reference.

CONTENTS

FEATURES & BENEFITS	3
IMPORTANT INFORMATION & SAFETY	4
SAFETY	5
DO'S AND DON'TS	6
INSTALLATION & ASSEMBLY	7
POSITIONING THE BARBECUE	8
PORTABLE GAS CYLINDERS	9
LEAK TEST	10
USING THE BARBECUE	11
MAINTAINING YOUR BARBECUE	12
TROUBLESHOOTING	13
CONNECTING NATURAL GAS	14
PARTS DIAGRAM	15
ASSEMBLY INSTRUCTIONS	16
LIST OF SPARE PARTS	23
MATADOR WARRANTY	26

CONTACT INFORMATION

For spare parts order from your nearest Bunnings Warehouse.

Australia for service and warranty queries, please go to the Garth support website: www.garthsupport.com or call 1800 427 841

New Zealand for service and warranty queries, please go to your local Bunnings warehouse or call 09-9782200, Fax 09-9782222, Email Marketing@bunnings.co.nz

www.matadorbbqs.com.au



MATADOR.

FEATURES & BENEFITS



BARBEQUE DIMENSIONS

	Length	Width	Height
Hood & BBQ (2B)	621 mm	587 mm	522 mm
	(4B) 891 mm	587 mm	522 mm
	(6B) 1060 mm	587 mm	522 mm
Cabinet (2B)	1190 mm	590 mm	889 mm
	(4B) 1464 mm	590 mm	889 mm
	(6B) 1632 mm	590 mm	889 mm

NOMINAL HOURLY GAS CONSUMPTION

2 Burner	4 Burner	6 Burner
TOTAL INPUT ULPG: 20.6Mj/hr INJECTOR SIZE: 0.9 mm PRESSURE: 2.75kPa	TOTAL INPUT ULPG: 41.2 Mj/hr INJECTOR SIZE: 0.9 mm PRESSURE: 2.75kPa	TOTAL INPUT ULPG: 61.8Mj/hr INJECTOR SIZE: 0.9 mm PRESSURE: 2.75kPa
Natural GAS: 17.6Mj/hr INJECTOR SIZE: 1.4 mm PRESSURE: 1.0kPa	Natural GAS: 35.2Mj/hr INJECTOR SIZE: 1.4 mm PRESSURE: 1.0kPa	Natural GAS: 52.8Mj/hr INJECTOR SIZE: 1.4 mm PRESSURE: 1.0kPa
TOTAL INPUT ULPG: 20.6Mj/hr INJECTOR SIZE: 0.9 mm PRESSURE: 2.75kPa	TOTAL INPUT ULPG: 41.2 Mj/hr INJECTOR SIZE: 0.9 mm PRESSURE: 2.75kPa	TOTAL INPUT ULPG: 61.8Mj/hr INJECTOR SIZE: 0.9 mm PRESSURE: 2.75kPa
Natural GAS: 17.6Mj/hr INJECTOR SIZE: 1.4 mm PRESSURE: 1.0kPa	Natural GAS: 35.2Mj/hr INJECTOR SIZE: 1.4 mm PRESSURE: 1.0kPa	Natural GAS: 52.8Mj/hr INJECTOR SIZE: 1.4 mm PRESSURE: 1.0kPa

AU

NZ

IMPORTANT INFORMATION AND SAFETY

This barbecue has been tested and certified in accordance with Australia Standards AS 4557:2004 and is approved for sale and distribution in Australia and New Zealand.

- Read the Instruction Manual thoroughly before assembling or using the appliance.
- Use OUTDOORS ONLY.
- Before installing the barbecue, consider the location of the gas supply and routing of the gas line. When choosing a location for your barbecue, keep in mind that it should not be located under or against any burnable surface.
- Before using the BBQ, remove any packaging material supplied within and around the BBQ for protection during transit.
- Any modifications to this barbecue may be dangerous. Parts sealed by the manufacturer or their agent must not be manipulated by the user.
- Never alter or modify the regulator or gas supply assembly.
- WARNING: Accessible parts may be very hot, please keep young children away.
- Do not move the appliance during cooking.
- Turn off the gas supply at the gas cylinder after use.

WARNING LABELS & STICKERS

Each barbecue has a number of permanent labels and point of sale (POS) stickers. While all POS should be removed prior to using, the permanent heavy duty labels should NOT be removed.

DATA PLATE:

Located on the body of your barbecue you will find the silver data label which contains important information relating to the testing and approval of this product, as well as the serial number and manufacturing date.

Always refer to the details on this data plate, if you need to contact the manufacturer for information, technical support or to order spare parts.

Record the serial number, place and date of purchase on the Warranty pages at the end of this document, for quick future reference.

GARTH AUSTRALIA PTY LTD Level 14, 140 William Street Melbourne, Victoria, 3000 AUSTRALIA Tel: 61 3 8566 1600 Fax: 61 3 9391 7287 www.garth.com.au								Gas Type: LPG Test Point Pressure: 2.75 bar
<input type="checkbox"/> MATRDO R 2 612-1	<input type="checkbox"/> MATRDO R 3 616-5	<input type="checkbox"/> MATRDO R 4 617-1/620-1/621-1/622-1/623-1/624-1	<input type="checkbox"/> MATRDO R 5 617-1/620-1/621-1/622-1/623-1/624-1	<input type="checkbox"/> MATRDO R REAR BURNER 625-1/626-1/627-1/628-1/629-1/630-1	<input type="checkbox"/> MATRDO R MID K BURNER 631-1/632-1/633-1/634-1/635-1/636-1			
<input type="checkbox"/> TOTAL INPUT LPG: 20.0kW FLUE GAS SIDE: 0.0mm PRESSURE: 2.75kPa	<input type="checkbox"/> TOTAL INPUT LPG: 20.0kW FLUE GAS SIDE: 0.0mm PRESSURE: 2.75kPa	<input type="checkbox"/> TOTAL INPUT LPG: 41.2kW FLUE GAS SIDE: 0.0mm PRESSURE: 2.75kPa	<input type="checkbox"/> TOTAL INPUT LPG: 81.2kW FLUE GAS SIDE: 0.0mm PRESSURE: 2.75kPa	<input type="checkbox"/> TOTAL INPUT LPG: 20.0kW FLUE GAS SIDE: 0.0mm PRESSURE: 2.75kPa	<input type="checkbox"/> TOTAL INPUT LPG: 10.0kW FLUE GAS SIDE: 0.0mm PRESSURE: 2.75kPa			
<input type="checkbox"/> NATURAL GAS: 17.0kW FLUE GAS SIDE: 14.0mm PRESSURE: 1.8kPa	<input type="checkbox"/> NATURAL GAS: 20.0kW FLUE GAS SIDE: 14.0mm PRESSURE: 1.8kPa	<input type="checkbox"/> NATURAL GAS: 20.0kW FLUE GAS SIDE: 14.0mm PRESSURE: 1.8kPa	<input type="checkbox"/> NATURAL GAS: 20.0kW FLUE GAS SIDE: 14.0mm PRESSURE: 1.8kPa	<input type="checkbox"/> NATURAL GAS: 20.0kW FLUE GAS SIDE: 14.0mm PRESSURE: 1.8kPa	<input type="checkbox"/> NATURAL GAS: 10.0kW FLUE GAS SIDE: 14.0mm PRESSURE: 1.8kPa			
GSCS20203						GSCS20175		
CLEARANCE FROM COMBUSTIBLE MATERIALS SIDES AND BACK: 480mm VERTICAL ABOVE: 1000mm								
SERIAL NUMBER:				DATE:				
FOR OUTDOOR USE ONLY								

SAFETY COMPLIANCE LABEL:

While there is a requirement under the Regulations for all gas products to be safe, the Australia / New Zealand regulatory environment establishes the limits of fundamental safety.

The Safety Compliance Label confirms that this barbecue has been certified as compliant and deemed suitable for importing and operation in Australia / New Zealand.



WARNING: The appliance must not be used indoors.

Contact your local Municipality for any building codes regulating outdoor barbecue installations.

When using an LPG supply system in an enclosure, ventilation must be provided. Gas vapour is highly explosive and can cause serious injury if allowed to accumulate in a confined space and ignited.



MATADOR

SAFETY

How do I use a ULPG Appliance Safely?

The safety record for gas appliances in Australia and New Zealand is excellent, and reflects both the high quality of appliances sold as well as growing consumer awareness about safe practice.

It is important that you READ THE MANUFACTURER'S INSTRUCTIONS thoroughly. If you have any questions or doubts, call the retailer or visit the Garth Support website.

www.garthsupport.com

If there is a leak:

- Turn the cylinder off.
- Ventilate the area to disperse gas.
- Check all connections.
- If the leak persists, keep the cylinder upright and take outside if possible. Keep skin away from any gas or liquid escaping from the cylinder.
- Keep the cylinder at least 20 metres away from any sparks or ignition sources, including electrical equipment, camera flashes, engines and motors.
- Disperse gas by encouraging maximum ventilation and spraying with a fine water spray.

If there is a fire:

- If the fire is at the barbecue, turn the gas off at the cylinder. Smother the flames with a wet cloth, fire blanket or extinguish using a fire extinguisher.
- If the fire is at the cylinder, or you can not get to the valve to turn the gas off, contact the fire brigade immediately.
- Using a garden hose, direct the water to the middle of the cylinder to keep it cool. Try not to extinguish the flame. At least if the gas is burning, it won't be able to build up pressure and explode.

Setting Up The Drip Tray

- Line the primary drip tray with foil.
- Put a fat absorbent material NOT sand or kitty litter in the small secondary drip tray.
- Ensure you regularly clean and replace the foil and fat absorber.
- Fat fires from the result of an excessive build up of grease and fats are NOT covered by Warranty.

A Note on Fire Prevention:

Most fires in outdoor barbecues are caused by a build up of fats and greases. Regularly cleaning of your barbecue is recommended. Refer to the Maintaining Your Barbecue section in this booklet for further information or visit the Garth Support website.

- NEVER operate this barbecue without a regulator.
- NEVER alter or modify the regulator or gas supply assembly.
- DO NOT connect your barbecue to an unregulated gas cylinder.
- DO NOT connect your gas barbecue to a gas cylinder exceeding this capacity
- TURN OFF the gas supply at the gas cylinder after use.
- DO NOT store empty or full spare gas cylinders under or near this or any other appliance
- Keep the gas hose away from hot surfaces and protect from dripping grease. Avoid unnecessary twisting of the hose. Visually inspect the hose prior to each use for cracks, excessive wear or other damage. Replace the hose if necessary.
- NEVER test for gas leaks with a lit match or open flame.
- NEVER light the barbecue with the hood closed or before checking the burner tubes are seated over the gas valve orifices.
- This barbecue must not be used indoors.
- WARNING: Accessible parts may be very hot. Keep young children away.
- This appliance must be kept away from flammable materials during use.
- Ensure that the barbecue is on a level and stable surface.
- DO NOT move this barbecue during use.
- Remove the drip tray before moving.

DO'S

- ✓ Have ULPG cylinder (LP units) filled by an authorised ULPG supplier.
- ✓ Check all gas line connections for leaks with a soapy solution prior to lighting and tighten until bubbles disappear.
- ✓ Preheat the barbecue for 2 - 5 minutes before cooking.
- ✓ After cooking, turn knob to hi setting for 5 minutes to burn off excess grease deposits. Then turn off gas at the knob and at the cylinder.
- ✓ Turn the gas off promptly should you be unable to light the barbecue immediately. Wait one minute before attempting to light again.
- ✓ Have proper tools, tongs, mittens and hot pads ready prior to removing foods.
- ✓ Trim excess fats from meats to minimize flare-ups.
- ✓ Let the barbecue cool before removing any parts for cleaning.
- ✓ Be careful of the control valve setting, hi - lo. A lower setting may generally be preferred.
- ✓ Minimum gas cylinder requirement is 9kg.



DON'TS

- ✗ Don't install the barbecue closer than 430mm on the sides or 430mm in the back to any combustible surface or less than 1 meter beneath any overhead combustible construction.
- ✗ Don't attempt any adjustment of the regulator. It has been preset and tested.
- ✗ Don't allow the ULPG cylinder to lie on its side. Keep it in an upright position.
- ✗ Don't turn a control knob on until a lighted match is inserted in the lighting hole ready to light burner (Manual ignition only).
- ✗ Don't use plastics or untempered glass utensils on the barbecue.
- ✗ Don't wear long loose flowing clothing around the barbecue. Long flowing hair is also easily ignited, especially by unexpected flare-ups. Tie hair back or wear a hat or scarf.
- ✗ Don't put food on the barbecue and leave it unattended or unwatched for long periods. Most fats can catch fire even on the lower setting.
- ✗ Don't use caustic materials to clean barbecue parts.
- ✗ Don't exceed temperature of 480°F or 250°C with the hood closed.



Do not replace the grill with an extra hotplate. You will violate the gas approval and your warranty will be voided. The grill provides the ventilation needed for the barbecue to operate safely, it is not designed to be a solid hotplate device.

WARNING!



MATADOR.

INSTALLATION & ASSEMBLY

It is important to read these instructions thoroughly. If you have any problems, contact the manufacturer or contact the retailer.

1. The appliance must be installed in accordance with these Instructions and Installation requirements of the local Gas Authority and installation code AS-NZS 5601.
2. Before installing the barbecue, consider the location of the gas supply and routing of the gas line. If connecting to Natural Gas (approved models only), please refer to instructions on page 14. When choosing a location for your barbecue, keep in mind that it should not be located under any burnable surface. All sides, including the back, should not be any closer than 430 mm for a combustible surface. A minimum clearance height of 1 meter is required from any combustible surfaces overhead.
3. A 3/8" SAE male thread is exposed for connection on the right hand side.

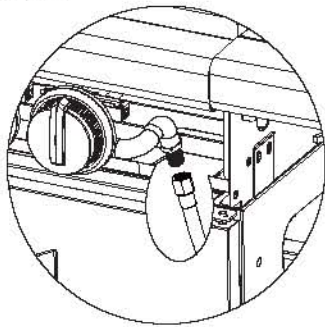

4. ULPG gas systems with a self contained gas supply should be connected as follows: Connect regulator and flexible hose, using a spanner, between the leg and the barbecue. Take care not to over tighten the joints. Never operate your barbecue without a regulator.

5. After connecting the gas supply, turn on the gas ensuring all gas valves are in the OFF position and check for leaks by brushing a soap and water solution over all joints. The presence of bubbles indicates a leak. Under no circumstances should a naked flame be used to check for leaks. If a gas odour is present and no leaks can be found, do not use the barbecue and refer to place of purchase.
6. Light each burner separately and inspect the flames. They should be a soft blue colour, with an occasional yellow tip. If the burner is noisy and the flames are sharp and bright blue, or conversely, is hazy with considerable yellow or there is a lack of heat from the burner, please clean the burners as detailed under Maintaining your Barbecue. If this does not rectify the problem please refer to the place of purchase.
7. If, after following the instructions, satisfactory performance cannot be obtained, please refer to your place of purchase.
8. **Seasoning the Cooking Surfaces**
 - Before using the BBQ for the first time, the cooking surfaces should be washed with a mild soap and water solution to remove any dust.
 - Dry the cooking surfaces and then apply a light coating of cooking oil.
 - Light your barbecue for the first time and turn all the burners to the LO position.
 - Leave burners alight for 30 minutes for curing.
 - Your barbecue is now seasoned and ready for your first barbecue.
9. **Service**

Other than general cleaning, servicing of this barbecue must be carried out by an authorised person.

NOTE: The regulator thread that connects to the cylinder is threaded anticlockwise.

NOTE: If your appliance fails to operate Successfully, please go to the Garth Support website: www.garthsupport.com or call 1800427841 (Australia), 0800357050 (New Zealand) for warranty assistance

POSITIONING THE BARBECUE

This appliance should only be used in an above ground, open air situation with natural ventilation, without stagnant areas, where gas leakage and products of combustion are rapidly dispersed by wind and natural convection.

Any enclosure in which the appliance is used shall comply with one of the following:

- An enclosure with walls on one side, but at least one permanent opening at ground level and no overhead cover.
- Within a partial enclosure that includes an overhead cover and no more than two walls.

Within a partial enclosure that includes an overhead cover and no more than two walls, the following shall apply:

- At least 25% of the total wall area is completely open; and
- At least 30% of the remaining wall area is open and unrestricted.

In the case of balconies, at least 20% of the total of the side, back and front wall areas shall be and remain open and unrestricted.

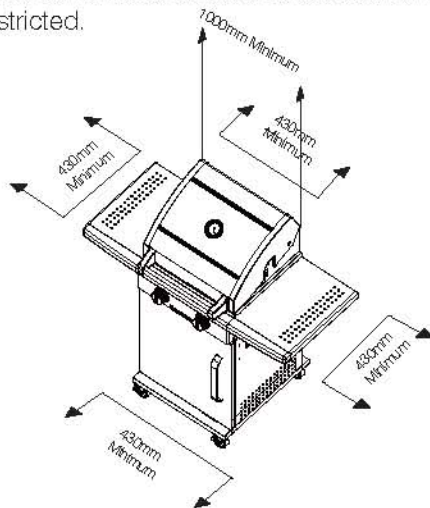

Minimum Distances from Combustible Material

The barbecue must not be installed under or on any combustible material. Minimum clearance from any combustible materials of ALL sides of the barbecue is 430mm and 1000mm overhead.

The following figures are diagrammatical representations of outdoor areas described. Rectangular areas have been used in these figures - the same principle applies to any other shaped area.

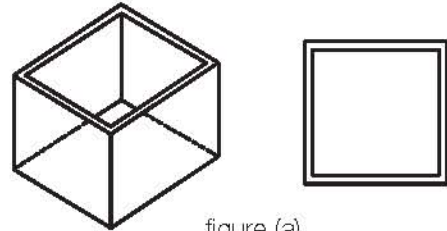

figure (a)

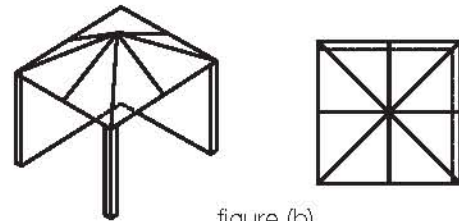

figure (b)

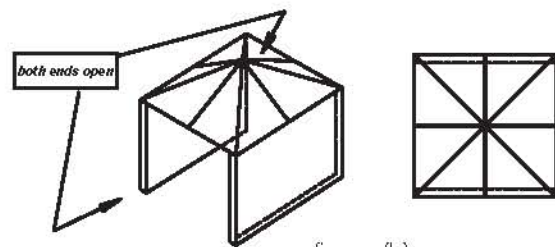

figure (b)

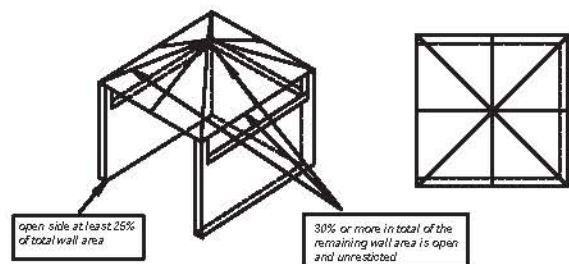

figure (c)

BARBECUES MUST BE INSTALLED IN ACCORDANCE WITH THE MANUFACTURER'S INSTALLATION INSTRUCTIONS, LOCAL GAS FITTING REGULATIONS, MUNICIPAL BUILDING CODES AND THE GAS INSTALLATION CODE AS/NZS 5601.

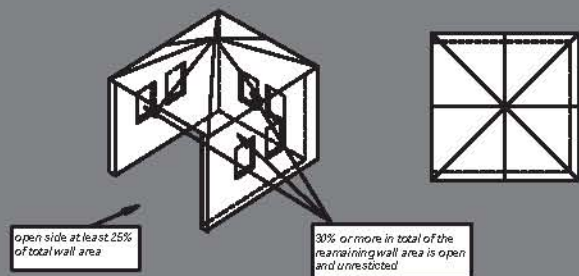

figure (d)



MATADOR

PORTABLE GAS CYLINDERS

What is Propane (AUS) / ULPG (NZ)?

Propane and ULPG are fuel gas compressed until it turns to liquid, then stored in a bottle or cylinder under pressure for easy transport.

The minimum size gas bottle to be used for this BBQ is 9Kg

How is it different from Natural Gas?

Propane (AUS) / ULPG (NZ) is similar to natural gas. It is colorless, non-poisonous and does not pollute when burnt. Appliances, like heaters or barbecues, that can work on natural gas can often be converted to work on Propane (AUS) / ULPG (NZ) and vice versa. There is one important difference - Propane (AUS) / ULPG (NZ) is heavier than air so if it escapes it does not float away. Instead Propane (AUS) / ULPG (NZ) will collect and form in gas pools at ground level or at the bottom of your appliance.

How do I connect the appliance to the gas cylinder?

There are three types of connection to Propane (AUS) / ULPG (NZ) cylinder. Some appliances require a hose and regulator. The regulator is a device attached to the hose to reduce the gas pressure.

The Dataplate on these appliances should indicate the correct pressure – e.g. "Propane (AUS) / ULPG (NZ) pressure, 2.75kPa."

Other appliances simply require a hose. These deliver gas at high pressure to the appliance. The dataplate on these should read "Cylinder Pressure Only".

Finally, some appliances are designed for direct connection to a certain type of cylinder (e.g. Primus or Companion). The data plate on these appliances should read "Cylinder Pressure Only".

IF THERE IS A GAS LEAK

1. Turn the gas cylinder off.
2. Ventilate the area to disperse any accumulated gas.
3. Check all connections.
4. If the leak persists, keep the cylinder upright and take to an open area.
5. Keep skin away from any gas or liquid escaping from the cylinder.
6. Keep the cylinder at least 20 meters away from any sparks or ignition sources including electrical equipment, camera flash, engines or motors.
7. Disperse gas by providing maximum ventilation and spraying with a fine water spray.

How do I use the Gas Cylinder?

Most Propane (AUS) / ULPG (NZ) cylinders work basically the same. There is a valve handle at the top, which you turn to release the gas. This works the same as a water tap, except that the gas is released at high pressure. Portable appliances often have a short length of hose which connects the gas bottle to the appliance.

A few simple rules here:

1. Store the cylinder safely

When you are not using your Propane (AUS) / ULPG (NZ) cylinder, store it where it cannot be knocked around and damaged. Store it away from direct heat and make sure that the area is well ventilated in case of slow leaks building up. Also, keep away from any other bottles of compressed gases and if possible, use a cylinder sealing plug to prevent leaks.

2. Always keep the cylinder upright.

3. Refilling

When the cylinder runs out of Propane (AUS) / ULPG (NZ), please swap the empty gas bottle for a full one through any gas exchange program.

4. Inspection

If you do not have a cylinder exchange program available in your area and have your gas cylinders filled, have the cylinder inspected EVERY 10 YEARS at an authorised testing station. The date of every inspection is imprinted onto the cylinder itself.

5. Repairs

Do not tamper with any fitting attached to any Propane (AUS) / ULPG (NZ) gas cylinder. Contact the supplier or an authorised testing station.

6. Keep protected from heat

Heat will increase the pressure inside the bottle due to the Propane (AUS) / ULPG (NZ) expanding. This could cause the safety valve to open and allow gas to escape. If the cylinder feels hot to the touch, keep the cylinder shielded from the appliance.

7. Hose Inspection

Check the gas hose and fittings for deterioration once a year or whenever replacing the gas cylinder. The hose must be replaced if it is cracked, split, cut or damaged.

Always turn off the gas supply at the gas cylinder after use.

LEAK TEST

Before lighting your barbecue it is important to carry out this simple test to check whether the gas cylinder, hose and regulator are working / connected correctly.

NEVER TEST FOR GAS LEAKS USING A LIT MATCH OR OTHER NAKED FLAME

①

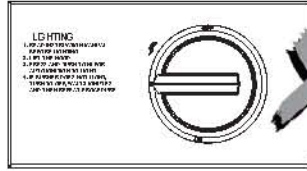
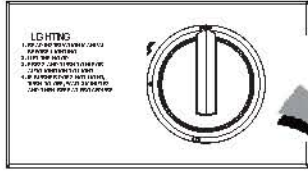

TURN OFF THE GAS VALVE

②

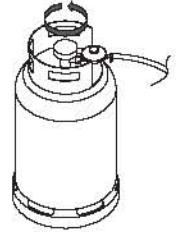

TURN OFF THE GAS BOTTLE

③

MAKE SOAPY WATER SOLUTION

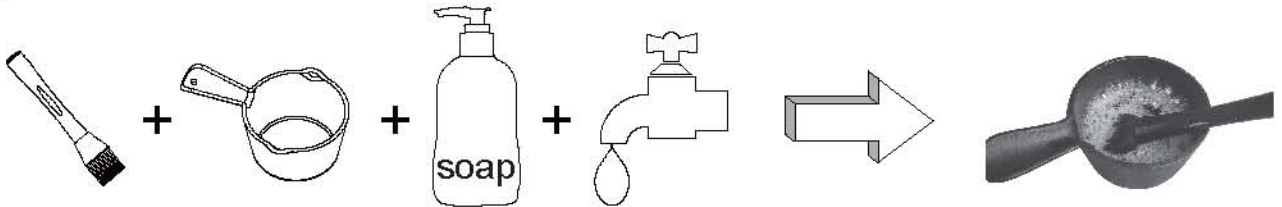

④

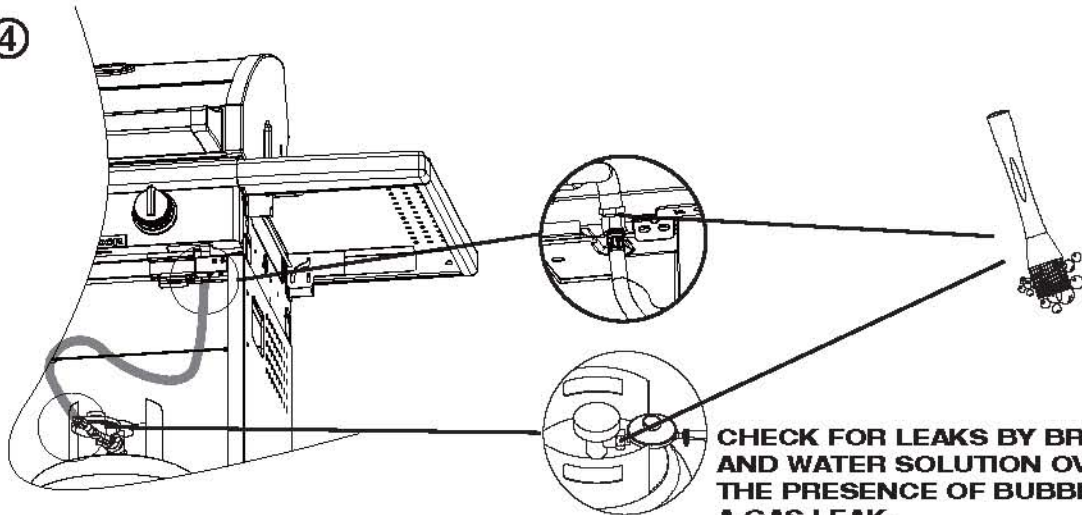

CHECK FOR LEAKS BY BRUSHING A SOAP AND WATER SOLUTION OVER ALL JOINTS. THE PRESENCE OF BUBBLES INDICATES A GAS LEAK.

⑤

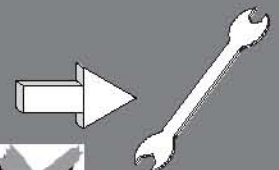
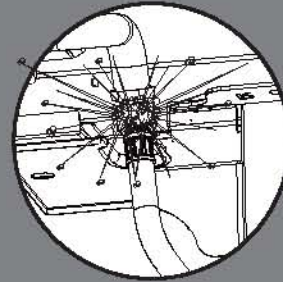
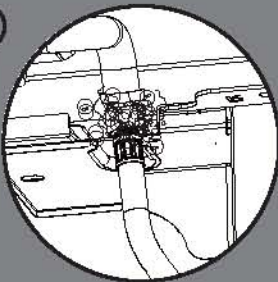

RE-TIGHTEN THE CONNECTION IF GAS LEAKAGE OCCURS



MATADOR

USING THE BARBECUE

LIGHTING INSTRUCTIONS

This BBQ uses a new type of ignition system; please see below for lighting procedures

NOTE: Light all main burner before lighting the side burner.

1. Push the control Knob in and turn slowly anti-clockwise to the ignition symbol.
2. Wait until you hear the gas coming through the burner, this may take 5-10 seconds.
3. Then turn the control knob from the ignition symbol to the **HI** position; you will hear a click as you do this, which should ignite the burner.
4. If you do not hear a click, turn the knob to the **OFF** position and leave for 2 minutes and then retry.

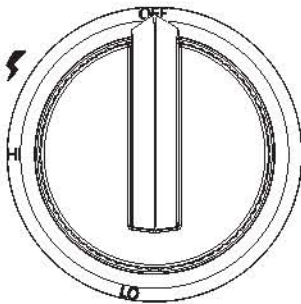

NOTE: It is important to ensure that all control valves, including the gas cylinder, are turned off after use.

FOR MANUAL IGNITION

1. Light a 90mm barbecue match or a lighting gun and hold adjacent to the lighter hole at the right end of the barbecue.

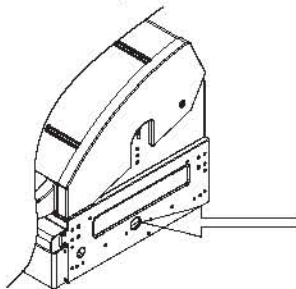

2. Turn the right hand gas control knob to the **HI** position. The burner will light from the match.
3. Once the right burner is lit, the burner next to it can be turned on and will light off the lit burner. Repeat till all burners are alight.

Each burner can be adjusted to provide a low setting by turning the gas control knob to the **LO** position.

PREHEATING

Light the burners as previously directed and turn to HI and allow the barbecue to preheat for 2 - 5 minutes.

PREPARE THE COOKING SURFACE

It is preferable to apply a light coat of cooking oil using a long handed brush to the cooking grills prior to lighting each time, the oil will keep food from sticking to the cooking surface.

USING THE HOOD WHEN COOKING

When using the barbecue with the hood closed, use the two outside burners only and do not exceed 250°C. Exceeding 250°C can damage the barbecue and void your warranty.

FLARE-UP CONTROL

Anytime you cook meat above an open flame you will have flare-ups which are caused when the natural juices from the meat fall on the flame tamers (diffusers) below the cooking plates.

Flare-ups, and the resulting smoke, are what give meat cooked over an open flame that delicious outdoor flavour. So expect and encourage some flare up.

However, excessive flaring can be caused by cooking extra fatty or marinated foods directly on the grill plates, by cooking with too high a temperature or by a build up of fats and residue in the drip tray beneath the burners.

These types of flare-ups should be controlled, or your food will burn.

To prevent excessive flare-ups, trim off excess fat from meat and poultry before placing on the grill, cook fatty or marinated meats on the barbecue plate and clean your drip tray regularly.

To control excessive flare-ups caused by too high a heat, turn the control knob down to a lower setting.

Throw a small amount of baking soda or gently spray a small amount of water (from a meat baster or spray bottle) directly onto the flame tamers to put out excessive flaring.

MAINTAINING YOUR BARBECUE

CARING FOR THE BURNERS & INJECTORS

To ensure continued satisfaction from your barbecue it is essential to keep the burners and injectors clean.

Under normal usage, your barbecue should be left burning for five minutes after cooking has ceased. This will burn off any excess fats, juices, etc.

Occasionally, after long cooking sessions, excess fats, juices and marinades can clog the burners. Remove the burners (see instructions below) and after brushing with a barbecue brush, wash in hot water and detergent – ensuring that all ports are free from detergent.

Rinse in water, shake of excess water and dry if possible. Return to the barbecue and light immediately to remove any remaining moisture.

Apply a light coating of cooking oil to the burners if the barbecue is not to be used for an extended period.

REMOVING THE BURNERS

1. Make sure the barbecue has been switched off and has completely cooled down if recently used.
2. Ensure all gas control knobs are set to the off position and the gas cylinder has been turned off.
3. Lift the grill plate and oil channel off the barbecue.

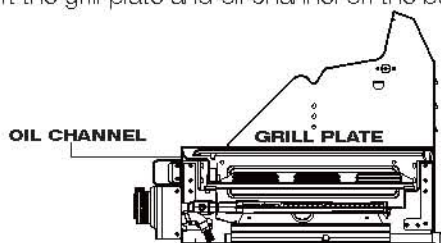

4. Lift the flame diffuser from position as shown below.

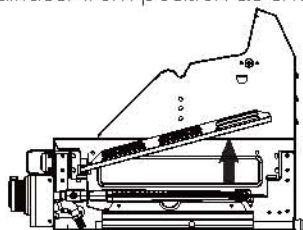

5. Remove the bolts at the rear of the BBQ from the burner.

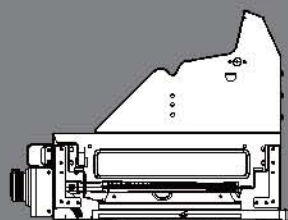

6. Lift and swing out the burner from position as shown below.

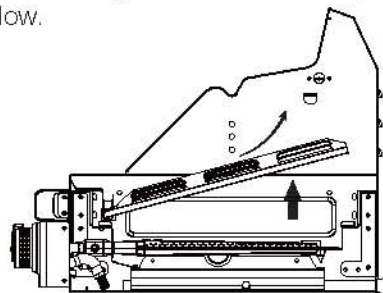

7. Simply reverse the previous procedure to reinstall the burners, flame diffuser and grill plate.

CARING FOR THE GRILLS & HOTPLATES

After cooking, turn the control knobs to the HI setting for five minutes to burn off any excess grease deposits.

Then turn off the gas at the control knob and at the cylinder. Let the barbecue cool before removing any parts for cleaning.

The grills and hotplates should be cleaned regularly depending upon usage and types of food cooked (ie sausages, fatty foods) to prevent a build up of fats and greases.

Cast Iron cooking surfaces should require washing. Simply heat the barbecue and use either a barbecue brush or tool to scrape the surface clean.

A light brushing with cooking oil should be applied to the grills and hotplates if the barbecue is not to be used for an extended period.

CLEANING THE BARBECUE

To ensure your barbecue is ready the next time you want to use it, turn all burners OFF and take a long handed brush and carefully brush off the cooking surfaces.

Remember to protect hands from the heat by using an oven mitt to hold the brush.

The barbecue body should also be cleaned regularly using hot water and detergent, depending upon usage to prevent a build up of fats and greases.

Remember to dry thoroughly and cover the barbecue securely with a weather proof cover.



MATADOR

TROUBLESHOOTING

My BBQ will not light properly. Why?

- Check LPG gas supply.
- Check to insure all gas connections are secure, including the gas hose connection to your Side Burner (most models).
- Check that the end of each burner is positioned properly over each gas valve.

When first lighting my BBQ I have a strong smell of gas.

- Check all connections are tight & then perform a **LEAK TEST** section in this instruction.

CAUTION - BEWARE OF FLASH-BACK:

Spiders and small insects occasionally spin webs or make nests in the bbq burners during transit and warehousing. These webs can lead to a gas flow obstruction which could result in a fire in and around the front of the burner. This type of fire is known as a "FLASH-BACK" and can cause serious damage to your bbq and create an unsafe operating condition for the user.

Although an obstructed Burner is not the only cause of "FLASH-BACK", it is the most common cause.

To reduce the chance of "FLASH-BACK", you must clean the burner before assembling your barbecue. Also perform the burner cleaning procedure on page 7 if your bbq has not been used for an extended period of time.

I found a damaged part while unpacking my new barbecue from the box. How do I get a replacement part? or

While assembling my new barbecue, I realised a part is missing. Who do I contact to replace parts that were missing from my box?

Garth Australia Pty Ltd stocks replacement parts for your gas barbecue. Follow these steps for fast and accurate part replacement:

- Locate the serial number of your BBQ as found on the silver data Label. This could be located on the bottom of the front fascia of the BBQ, the right hand side of the BBQ frame, on the rear of the BBQ frame or behind the cabinet door, depending on your model. Then, it's a good idea to write the serial number & date of purchase in the **MATADOR WARRANTY** section for quick future reference.

- Then, refer to the **LIST OF SPARE PARTS** to identify the missing part(s) and go to our Garth Support website **www.garthsupport.com**, or contact us on our free call number:
Australia - 1800 427 841
New Zealand - 0800 357 050

Note: Recommended Maintenance

Recommended maintenance should be carried out by an authorised person every 12 (twelve) months for the life expectancy of the appliance.

For Technical Assistance

If you experience any technical issues with your barbecue, in the first instance review the instruction manual or contact the Garth Customer Support Department through the Garth Support website at **www.garthsupport.com** for assistance.

For Spare Parts

To order spare parts, you can return to your place of purchase and ask them to order a part for you. Alternatively, you can order directly through the Garth Support website at **www.garthsupport.com**

You will need to provide the following information:

- Model of Barbecue
- Year of Purchase
- Part requiring replacement (refer to the Spare Parts List in your Assembly Manual)
- Name of the warranty service company (if applicable)

CONNECTING NATURAL GAS

This barbecue model is approved for conversion from Propane to Natural Gas (for Australia only).

The following steps are required to complete the conversion:

1. Contact a registered Gas Fitter / Plumber to obtain a quote for the conversion and to confirm whether this appliance will work efficiently with the current gas supply to your household, in accordance with the Installation Code AS5601.
2. The Gas Fitter / Plumber will need to source the necessary parts for the conversion.
(Note: Replacement jets can be ordered directly from Garth with an official Purchase Order and by quoting of the Gas Fitter / Plumber's Registration Number.)
3. Upon completion of the conversion, the Gas Fitter / Plumber is LEGALLY required to issue a Compliance Certificate.
4. DO NOT attempt to complete the conversion yourself.
5. Failure to comply with these requirements and Installation Code AS 5601 will automatically void the Warranty for this product.



MATADOR

PARTS DIAGRAM

FOR B323-1

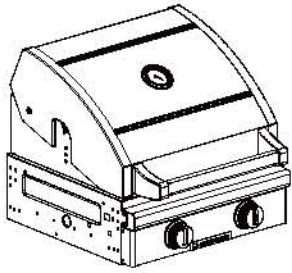

1. BBQ Frame + Hood X1

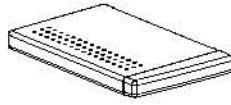

2. Left Side Shelf X1

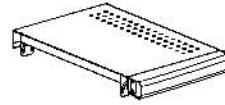

3. Right Side Shelf X1



4. Side Shelf Bracket-1 X1



5. Side Shelf Bracket-2 X1



6. Fibre Plate X2

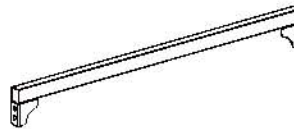

7. Cabinet Front Top Cross Bar X2



8. Door Top Bracket X1



9. Magnet X2



10. Door bottom bracket X1



11. Cabinet Support Corner X2



12. Castor X4

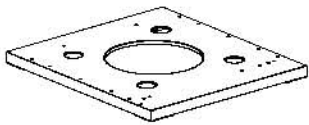

13. Cabinet Bottom Panel X1

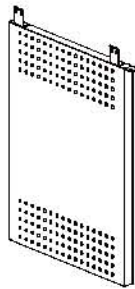

14. Cabinet Left Side Panel X1

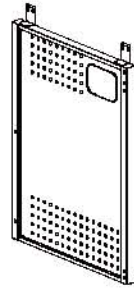

15. Cabinet Right Side Panel X1

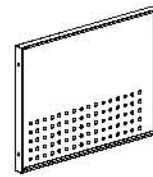

16. Cabinet Back Panel X1

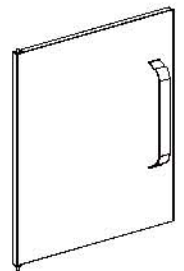



17. Door X1

 4: M4 x 10mm

 54: M5 x 10mm

 6: M6 x 10mm

 8: M6

 8: M6

ASSEMBLY INSTRUCTIONS

STEP 1

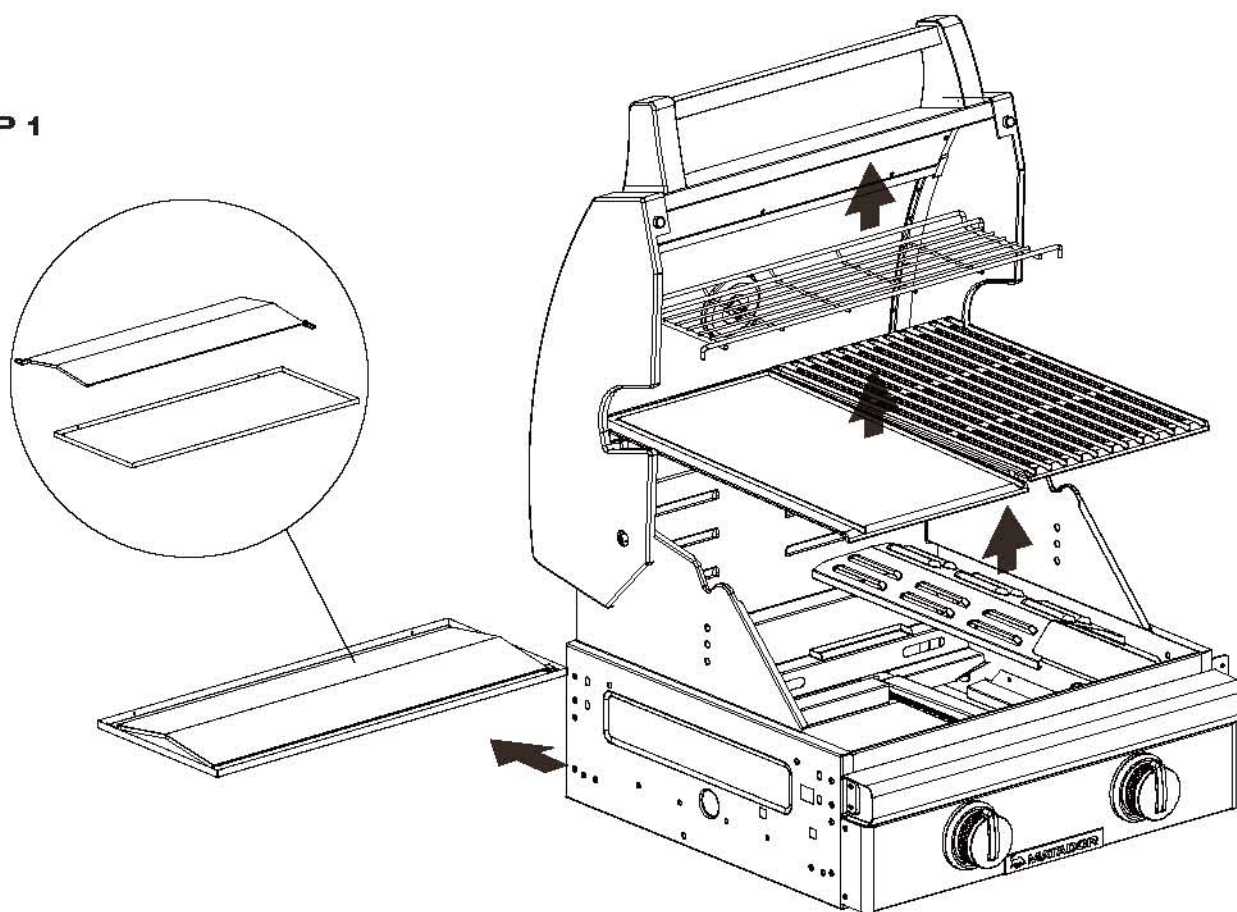

STEP 2

 2: M4 x 10mm

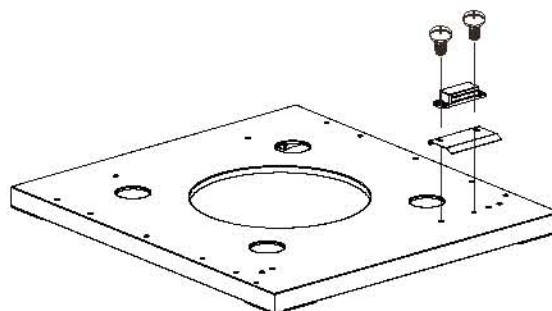

MATADOR

STEP 3

 16: M5 x 10mm

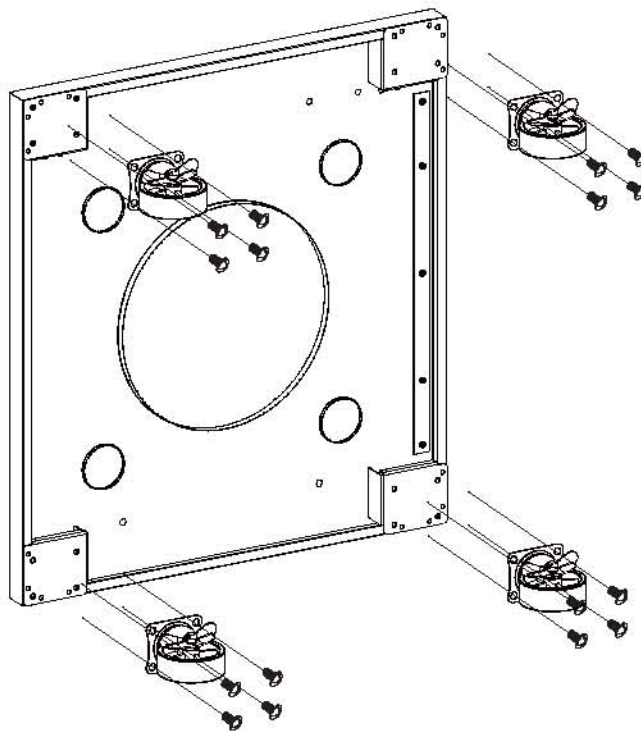

STEP 4

 6: M6 x 10mm

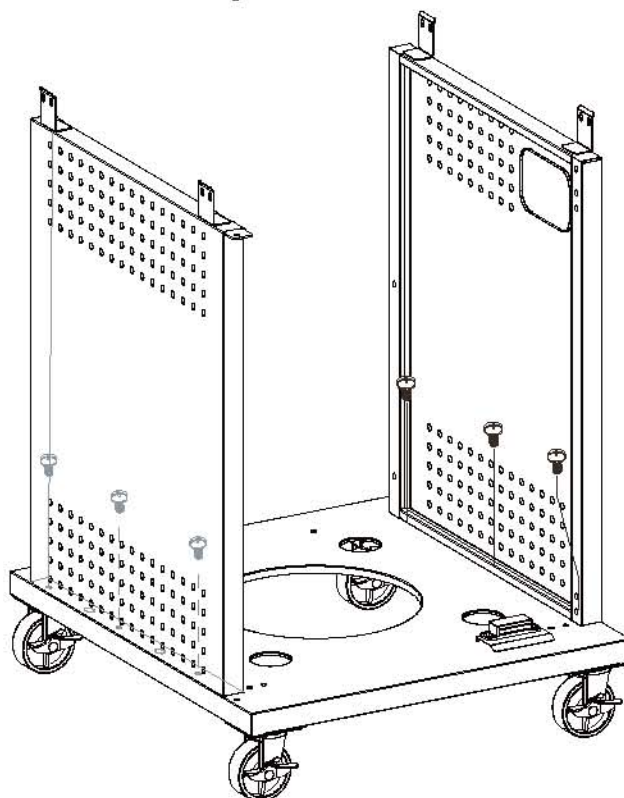

STEP 5

 2: M4 x 10mm

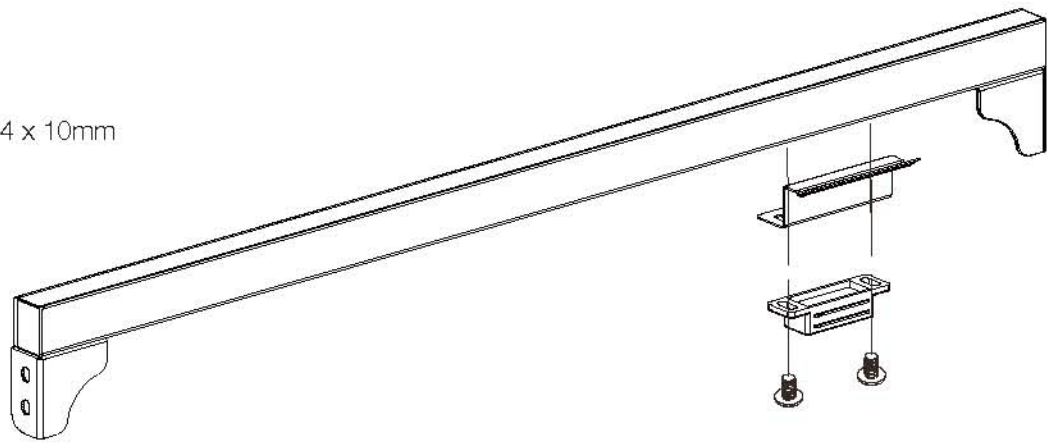

STEP 6

 4: M5 x 10mm

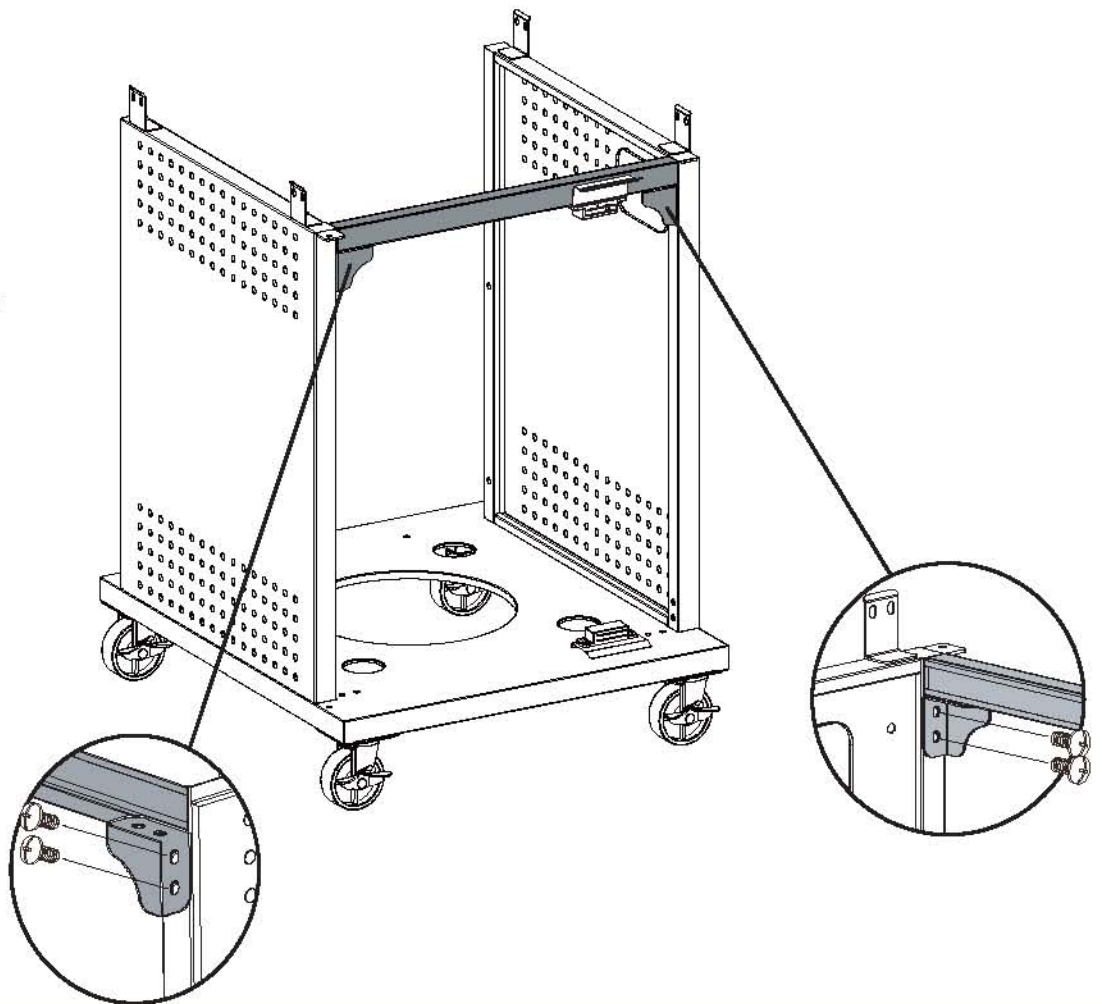

MATADOR

STEP 7

 10: M5 x 10mm

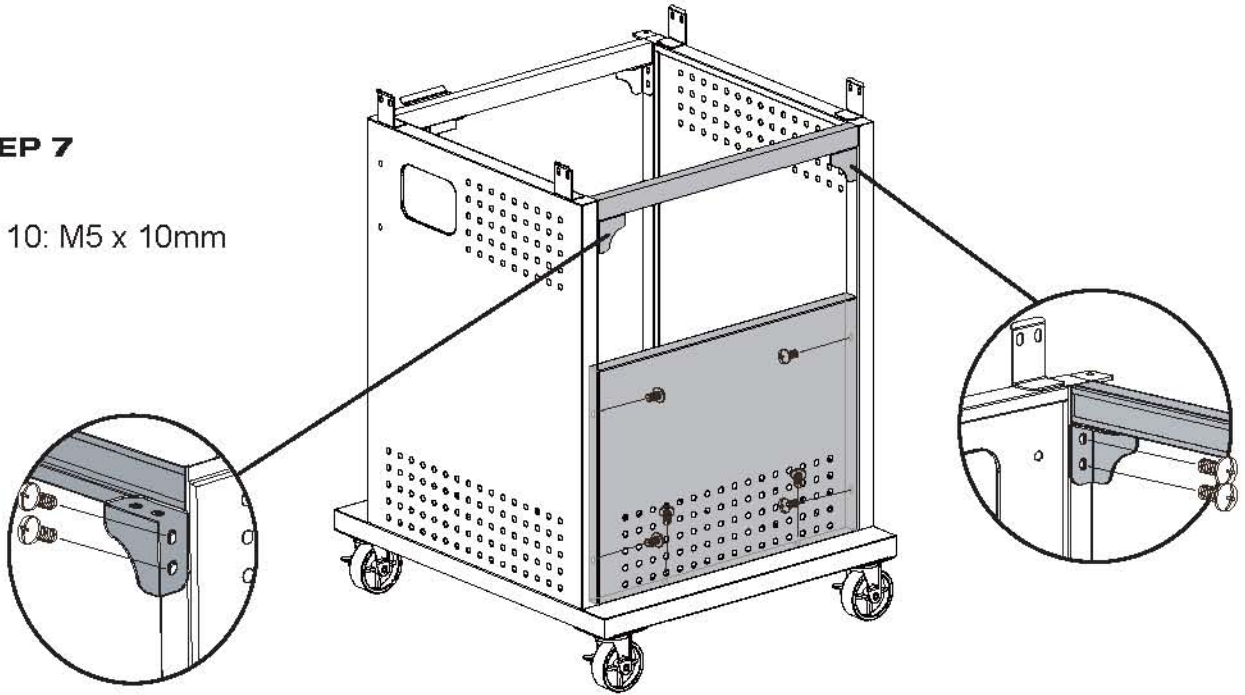

STEP 8

 8: M5 x 10mm

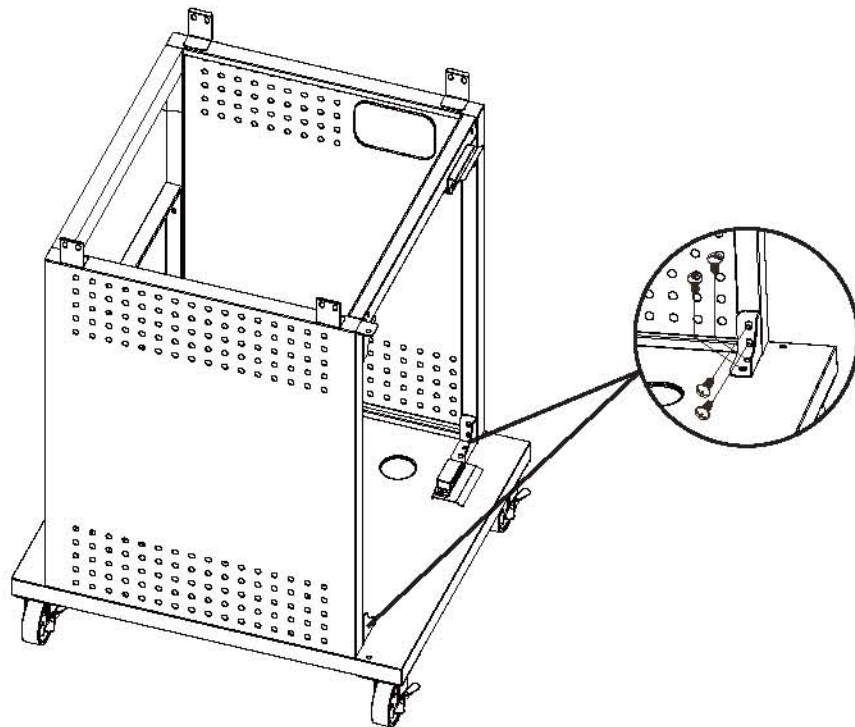

STEP 9

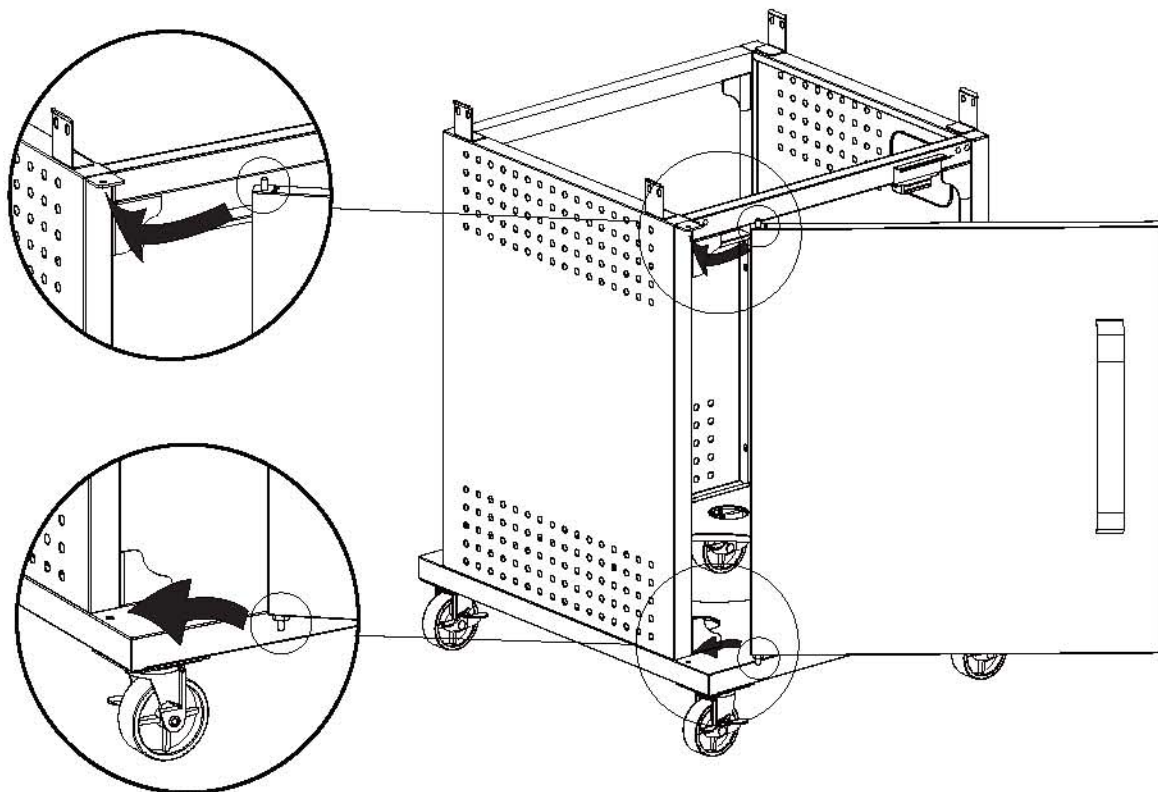

STEP 10

 8: M5 x 10mm

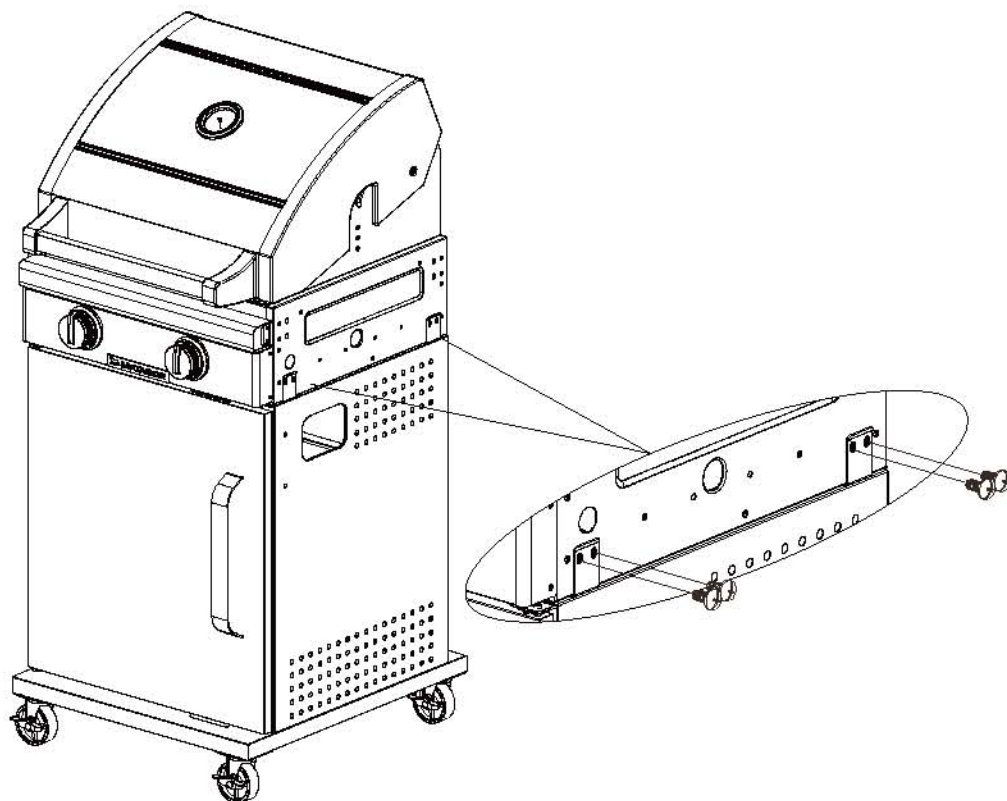

MATADOR

STEP 11

 8: M5 x 10mm

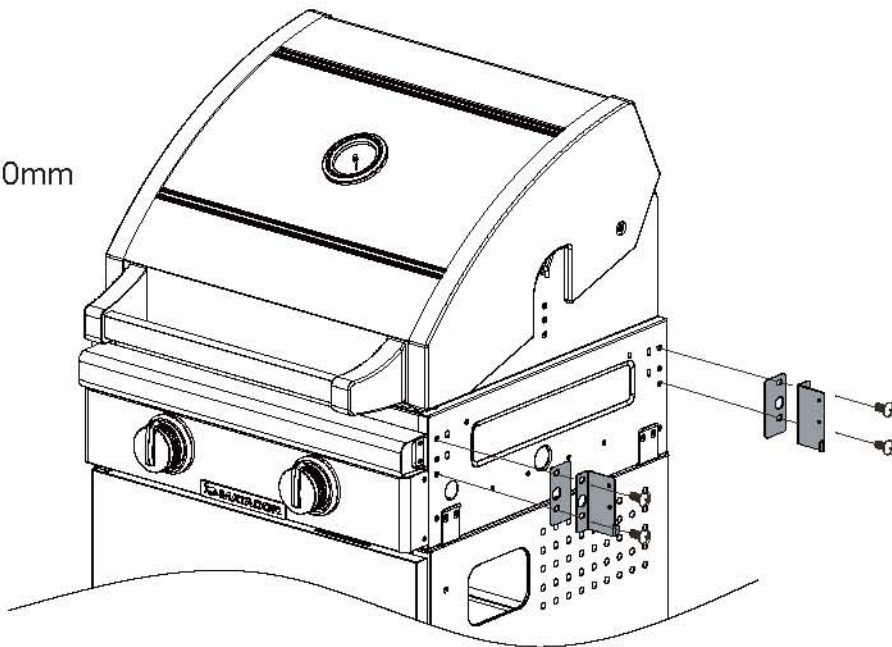

STEP 12

 8: M6

 8: M6

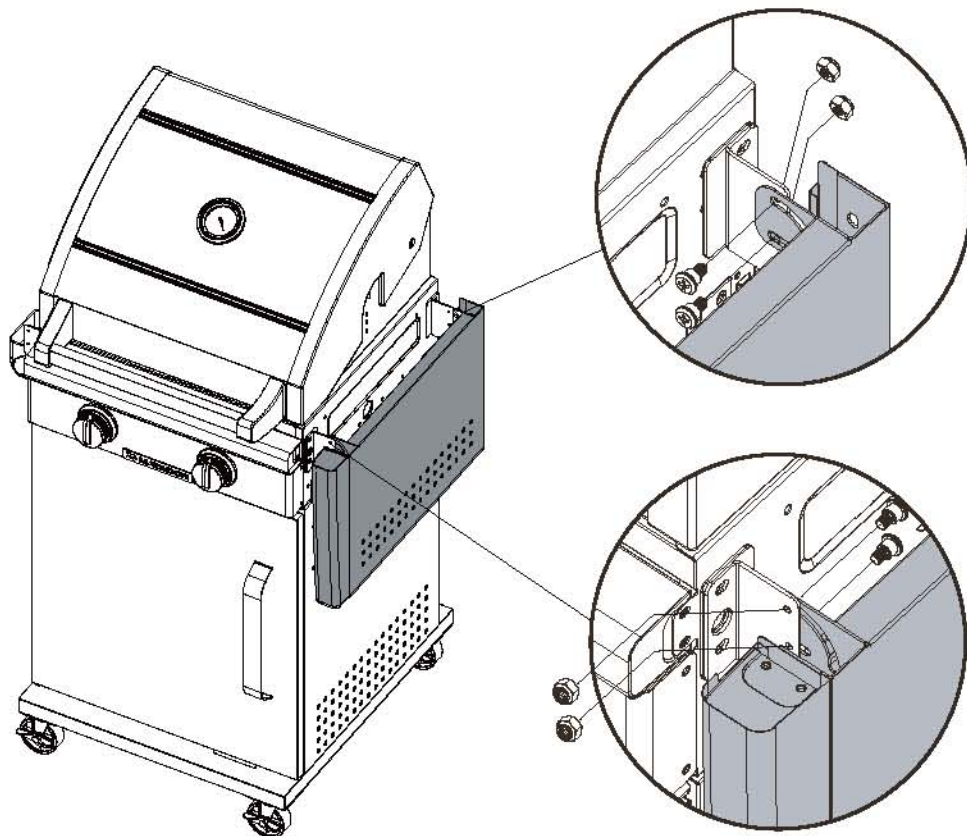

STEP 13



STEP 14

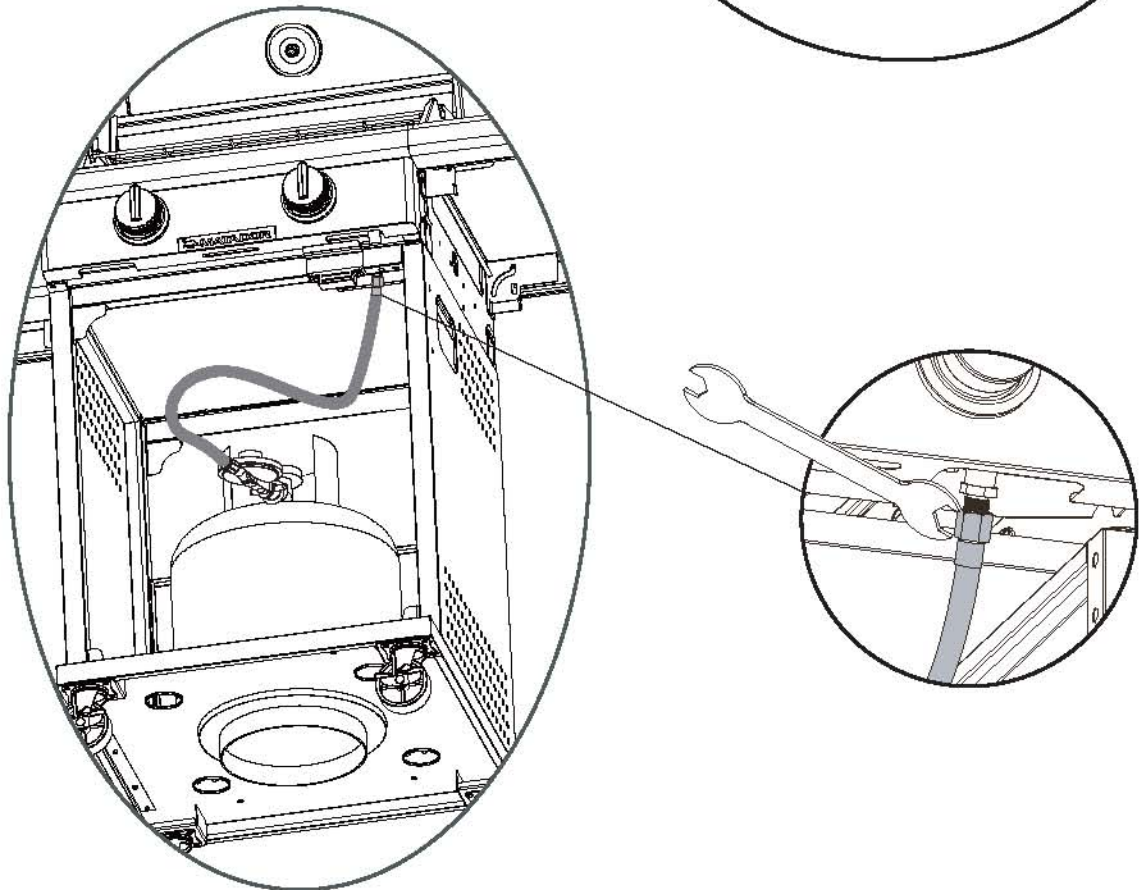

MATADOR

LIST OF SPARE PARTS

For spare parts refer to your store of purchase.

For warranty visit:
www.garthsupport.com

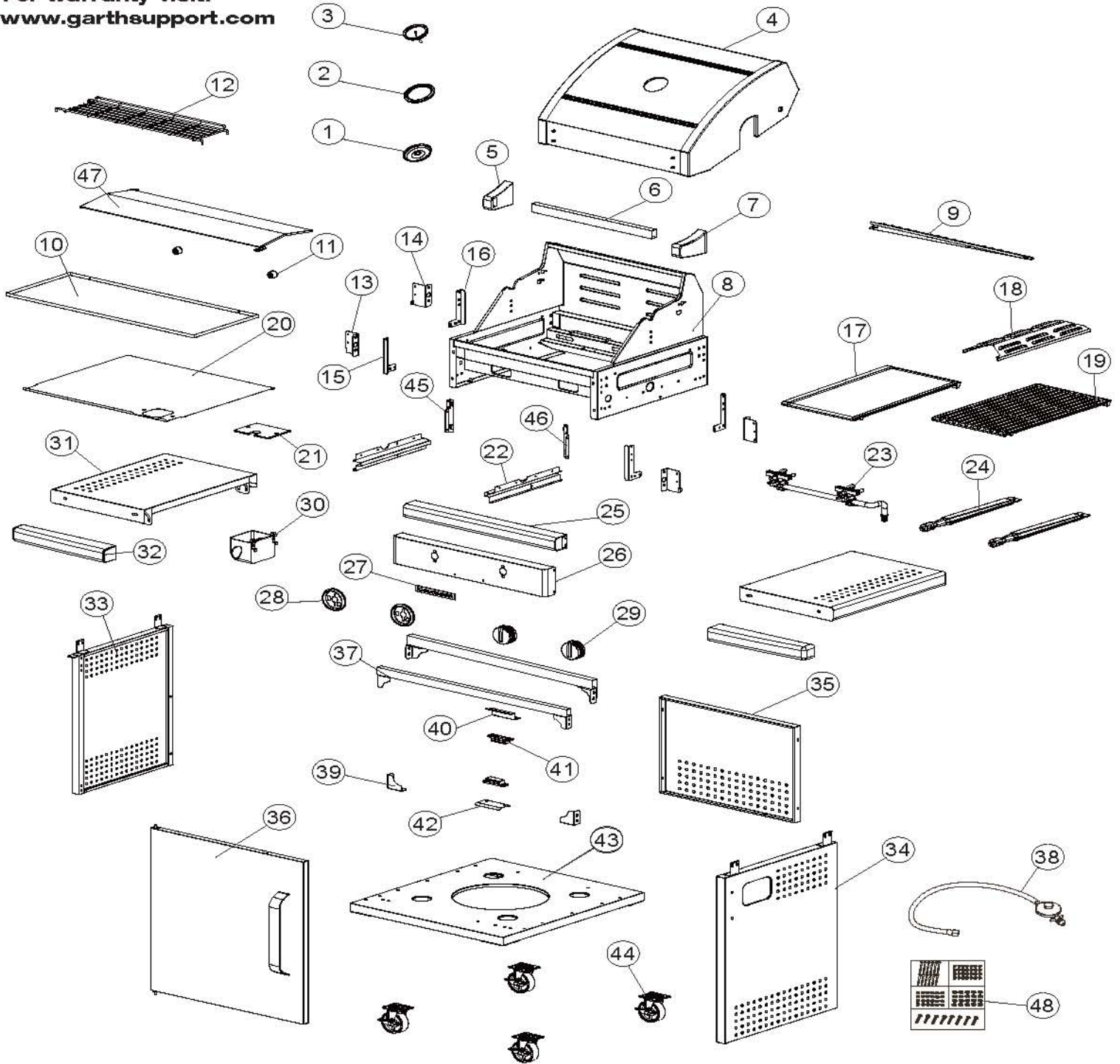

PART NUMBER	PART NAME	SUPPLIER CODE	AVAILABLE OR NOT
1	Temperature Gauge Bowl	TG-B05	
2	Temperature Gauge Bezel	BS111019	
3	Temperature Gauge	N06021	
4	Hood Outer	B323-H-01	N/A
5	Left Hood Handle Base	B316-H-02	
6	Hood Handle	B316-H-03	N/A
7	Right Hood Handle Base	B316-H-04	
8	BBQ Frame	B323-B-01	N/A
9	Oil Channel	OC-2B	
10	Fat Tray Panel	B323-B-02	N/A
11	Fat tray knob	PHPB-036	
12	Warming Rack	B323-B-03	
13	Side Shelf Bracket-1	B323-T-01	
14	Side Shelf Bracket-2	B323-T-02	
15	Right Side Shelf Strong Bracket	B316-B-02	N/A
16	Left side shelf strong bracket	B316-B-01	N/A
17	Grillsmart Hotplate	B03409	
18	V Shape Flame Tamer	FT-B323-1	
19	Grillsmart Grill	B03410	
20	Gas bottle heat shield	B323-B-04	N/A
21	Regulator cover	B316-B-05	N/A
22	Oil Panel	B316-B-09	N/A
23	Main burner Gas Valve	GC-041A	
24	Burner	BR150317	
25	BBQ Front Decoration Strip	B323-B-06	N/A
26	Fascia	B323-B-07	N/A
27	Badge	BA-B2015	
28	Control Knob Bezel	BS140521	
29	Control Knob	BKNB-217A	
30	Oil Cup	B316-B-10	
31	Side Shelf	B316-B3-02	N/A
32	Side Shelf Decoration Strip	B316-B3-01	N/A
33	Cabinet left side panel	B316-T-06	N/A
34	Cabinet Right side panel	B316-T-07	N/A
35	Cabinet back panel	B323-T-03	N/A
36	Cabinet Door	B323-T-04	N/A
37	Cabinet front top cross bar	B323-T-05	N/A
38	Hose and Regulator	RC008002	



MATADOR

PART NUMBER	PART NAME	SUPPLIER CODE	AVAILABLE OR NOT
39	Cabinet Support Comer	B316-T-08	N/A
40	Door top bracket	B316-T-10	N/A
41	Magnet	DRSP-1	
42	Door bottom bracket	B316-T-12	N/A
43	Cabinet Bottom Panel	B323-T-06	N/A
44	Castor	VM110416	
45	Left fascia mounting bracket	B316-T-09	N/A
46	Right fascia mounting bracket	B316-T-11	N/A
47	Fat tray panel heat shield	B323-B-08	
48	Bolt Pack	BP-B323-1	

MATADOR WARRANTY

Thank you for purchasing one of our quality Matador BBQs.

YOUR MATADOR BBQ IS COVERED AGAINST DEFECTS FOR A PERIOD OF 5 YEARS FOR PARTS AND LABOUR, REPAIR OR REPLACEMENT. THIS WARRANTY EXCLUDES SURFACE RUST AND DAMAGE CAUSED BY ABUSE OR NEGLIGENCE.

CONDITIONS OF THE WARRANTY

- The appliance must be operated and maintained in accordance with the instructions supplied in the operating manual.
- Any repair does not extend the warranty period.
- Any parts other than original Matador parts will void this warranty.

Installation Conditions

- All installations must conform to the applicable Gas, Electrical and Building standards as laid down by the local codes for state or region.
- If the appliance is changed to natural gas (if applicable), it must be converted and installed by a licensed gas fitter.

FOR WARRANTY CLAIMS

Garth Australia Pty Ltd.
134 Hall Street
Spotswood
Victoria 3015
AUSTRALIA

Garth Support website: www.garthsupport.com
or call: 1800 427 841
email: service@garth.com.au

The warranty for New Zealand is given by
Bunnings NZ Ltd
PO Box 14436,
Panmure, Auckland, 1741
NEW ZEALAND

Tel: 09-9782200
Fax: 09-9782222
Email: marketing@bunnings.co.nz

Any claim under this warranty must be made within 5 years of the date of purchase of the product.

Proof of purchase must be presented.

For Australian Customers

To make a claim under the warranty please contact Garth support website: www.garthsupport.com or return the product (with proof of purchase) to any Bunnings store. (see: www.bunnings.com.au for store locations)

Garth Australia bears reasonable, direct expenses of claiming under the warranty.

The warranty covers manufacturer defects in materials, workmanship and finish under normal use.

This warranty is provided in addition to other rights and remedies you may have under law: our goods come with guarantees which cannot be excluded under the Australian Consumer Law. You are entitled to replacement or refund for a major failure and to compensation for other reasonably foreseeable loss damage. You are also entitled to have the goods repaired or replaced if the goods fail to be of acceptable quality and the failure does not amount to a major failure.

The warranty excludes damage resulting from product misuse or product neglect. The warranty covers domestic use only and does not apply to commercial applications

For New Zealand Customers

To make a claim under the warranty, take the product (with proof of purchase) to any Bunnings store (see www.bunnings.co.nz for store locations).

Bunnings NZ Ltd bears reasonable, direct expenses of claiming under the warranty. You may submit details and proof to our store for consideration.

The warranty covers manufacturer defects in material, workmanship and finish under normal use.

The warranty is provided in addition to other rights and remedies you may have under law: our goods come with guarantees which cannot be excluded under the Consumer Guarantees Act 1993 (NZ). You are entitled to replacement or refund for a major failure and to compensation for other reasonably foreseeable loss or damage. You are also entitled to have the goods repaired or replaced if the goods fail to be of acceptable quality and the failure does not amount to a major failure.

The warranty excludes damage resulting from product misuse or product neglect. The warranty covers domestic use only and does not apply to commercial applications.

Goods presented for repair may be replaced by refurbished goods of the same type rather than being repaired. Refurbished parts may be used to repair the goods.



MATADOR.

WHAT IS NOT COVERED IN THE WARRANTY

- Removal or re-installation costs. This warranty does not cover costs for transit, nor in home service.
- Liability will only be accepted for loss or damage during transit if at the time the product was being transported by Bunnings or a Bunnings approved contractor.
- Lack of maintenance, abuse, neglect, misuse, accidental or improper installation of this appliance.
- Scratches, dents, corrosion or discoloration caused by heat, abrasive chemical cleaners or chipping of porcelain enamel parts.
- Corrosion or damage caused by exposure to the elements such as insects, weather, hail or grease and fat fires.
- Rusting of cast iron plates, grills and burners.
- Cleaning and wear and tear; service calls of this nature are chargeable.
- Commercial use of the product.
- Unauthorized repairs or modifications during the warranty period.
- Glass breakage due to misuse or overheating
- Consumable items, example - batteries.

RECORD THE FOLLOWING INFORMATION

Attach the copy of the purchase receipt here:

Date of Purchase

Purchased From.....

Location.....

Model Name and Number

Serial Number

Receipt Number

Note: The serial number is located either on the outside of the packing carton or outside or inside the appliance.

FOR TECHNICAL ASSISTANCE

For Australia customers if you experience any technical issues with your Matador BBQ, in the first instance review the instruction manual or contact the warranty service agent below.

For New Zealand customers if you experience any technical issues with your Matador BBQ, in the first instance review the instruction manual or contact your local Bunnings warehouse.

FOR SPARE PARTS

Call your local Bunnings warehouse and ask them to order a part for you. You should provide the following information.

Model of Wok Burner.....

Year of purchase

Name of warranty service
company above

Part that requires replacement
(refer to the list of spare parts in the
instruction manual)



Visit www.matadorbbqs.com.au

For technical and warranty support call

1800 427 841 (Aus)

0800 357 050 (NZ)

Your purchase receipt will be required for warranty claims.

For spare parts contact your local Bunnings Warehouse