

## INSTALLATION AND CARE INSTRUCTIONS

**THESE INSTRUCTIONS MUST BE READ BEFORE INSTALLATION IS ATTEMPTED. FAILURE TO DO SO MAY COMPROMISE WARRANTY. FOLLOWING INSTALLATION PLEASE LEAVE ALL PAPERWORK WITH CLIENT AS IT CONTAINS IMPORTANT INFORMATION ON HOW TO UNDERTAKE ONGOING CARE FOR YOUR GREY WATER PUMP TOGETHER WITH WARRANTY PAPERS.**

### 1. Description - THIS UNIT IS FOR DOMESTIC USE ONLY

The compact Grey Water Pump is designed to receive and pump away waste water from a washing machine, dishwasher, shower, bath or vanity basin.

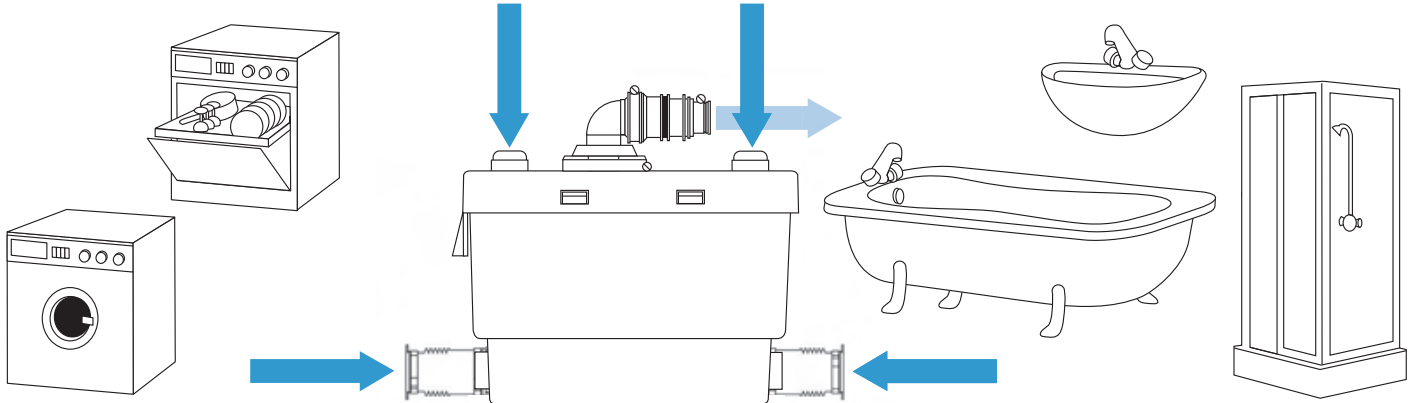

The Grey Water Pump will activate automatically following the inflow of waste water from any of the above fixtures.

Please pay particular attention to the following:



**Possible danger to personnel**



**Warning of possible electrical hazard**

**“ATTENTION” This is a general warning that failure to follow instructions could result in poor functioning of the unit.**

This pump benefits from the latest technological innovations concerning soundproofing. To benefit fully from the advantages provided by this new generation of appliances, it is important to comply with the installation instructions in section 5, 6 and 7.

### 2. List of Accessories included

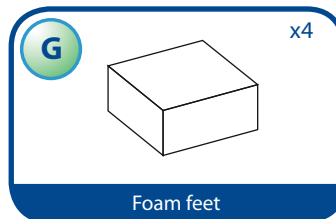
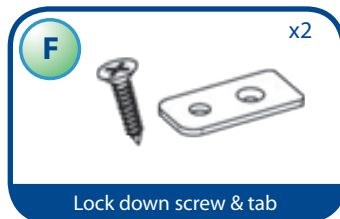
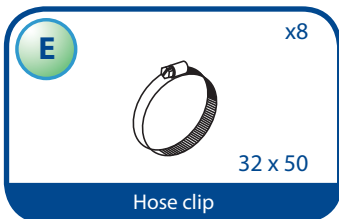
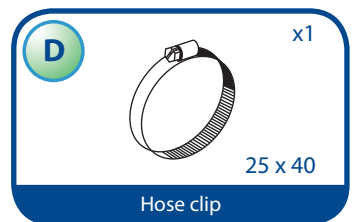
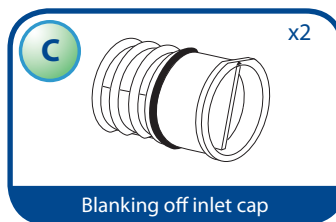
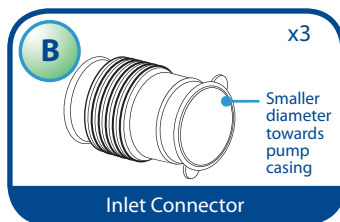
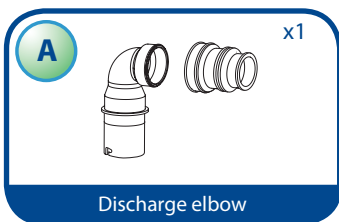

### 3. Dimensions and overall measurements

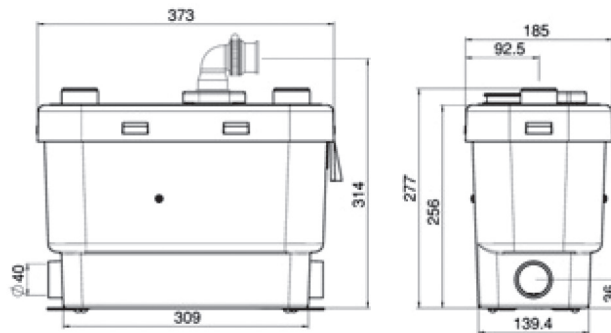

### 4. Performance curve

USE ONLY Ø 25MM PRESSURE PIPE FOR THE VERTICAL LIFT

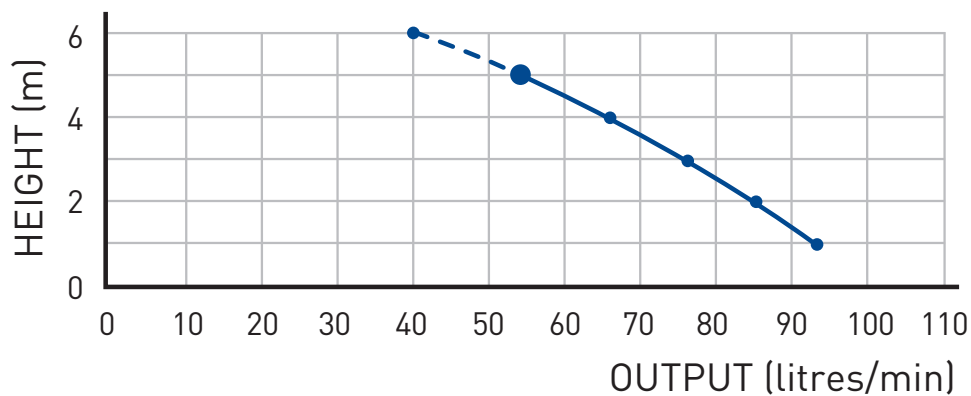

### 5. Vertical and horizontal pumping parameters

All elbows must be 2 x 45°

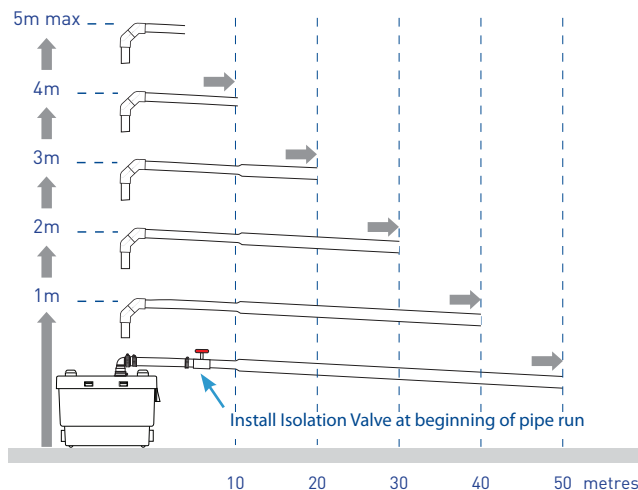

All horizontal pipework requires a minimum of 1:100 fall

Following vertical lift, increase discharge pipe diameter by one size on the Horizontal run to Sewer or vent connection.

**N.B. VERTICAL LIFT MUST PRECEDE HORIZONTAL RUN**

## 6. Installation

TO BE UNDERTAKEN BY A REGISTERED PLUMBER IN CONJUNCTION WITH: AS3500 10:10

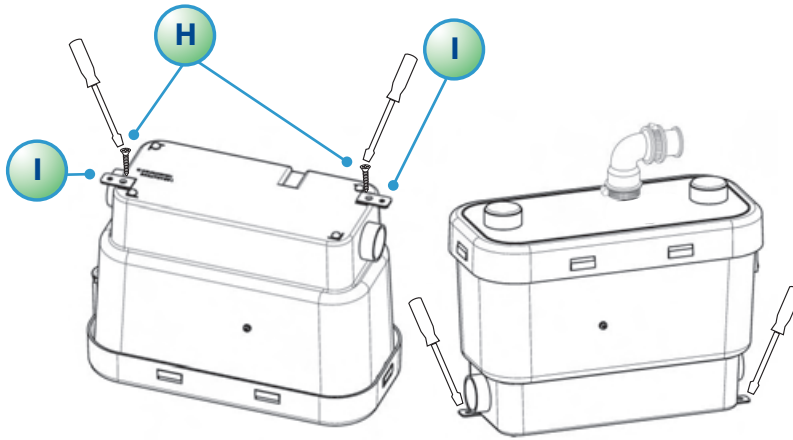

- The Grey Water Pump should be installed to allow full access in the event that servicing and or removal is necessary.
- The Grey Water Pump is supplied with floor mounting lugs and foam feet to minimise vibration and to prevent possible movement during operation.
- The Grey Water Pump must be located on the same floor level to that of all incoming fixtures. Do not locate in a pit or in-ground opening.

### Connections - Incoming waste water

- All pipework (32/40/50mm) from incoming fixtures must have a constant grade of 1:40.
- The Grey Water Pump has 4 possible inlet-ports, 2 on top of the lid and 1 at either lower end of pump casing.
- If using the lid ports use a stanley blade or hack-saw to remove the very top of the port to allow connection.
- Use rubber connectors and pipe clips (supplied) to make secure connections. Ensure connectors are facing in the right direction before securing. See diagram **B** on page 1.
- If you are not using the lower ports, then insert screwed (quarter turn) Blanking plugs (supplied) into lower ports and secure.

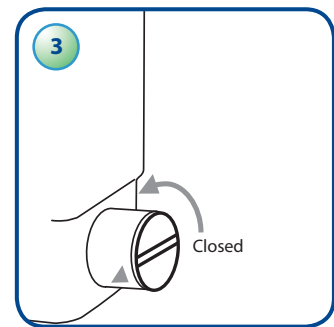
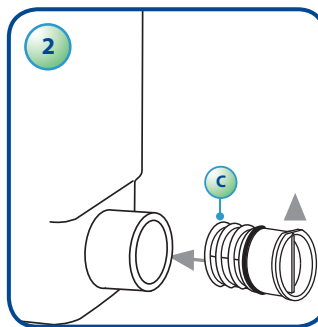
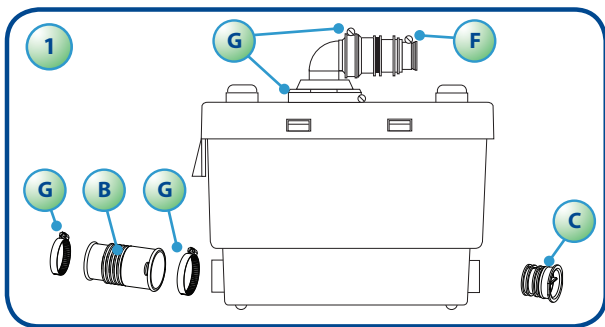

- To make the connection to the side inlets, use rubber connector (**B**). Secure it with metal hose clips (**G**).
- Cap off unused inlets with plugs (**C**).

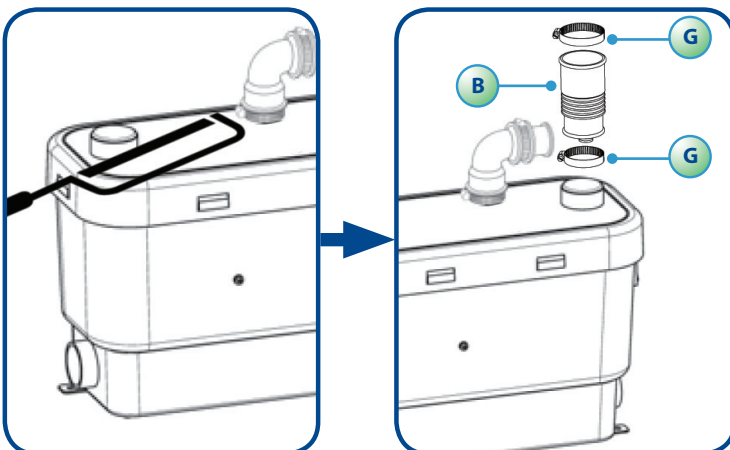

To connect to a lid inlet, cut off the sealed cap with a Stanley knife or hacksaw and connect using the rubber connector (**B**) provided. Tighten with the metal hose clips (**G**). The small diameter faces the pump lid, the larger diameter accepts incoming waste line.

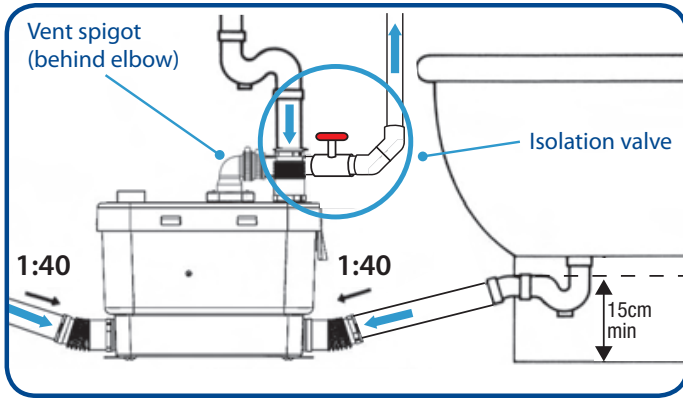

To connect a shower/bath, ensure that the trap exit is at least 15cm above floor level. Although not obligatory, a lid connection may be used to run an external air vent.

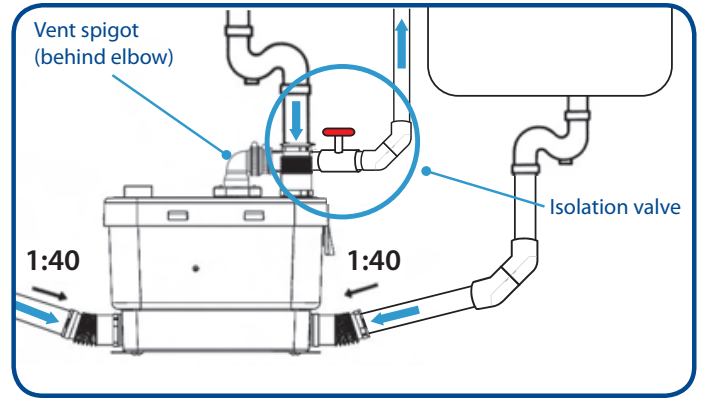

Ensure that the trap exit is at least 15cm above floor level.

### Connections - Discharge outgoing waste water

#### Select discharge pipework as follows:-

- Vertical lifts must occur prior to any horizontal runs, except for the initial short run at the pump connection, this should be NO MORE than 300mm in length.
- Only ONE vertical lift is permitted in the discharge line, all changes of direction in the discharge line MUST be made with 45deg bends rather than 90deg bends.
- For vertical pipe-work USE ONLY 25mm upvc (pressure pipe)
- Horizontal pipe-work (following initial vertical lift ) can be upgraded by one size to 32mm.  
If manifolding more than one pump, sizing should be in line with fixture loading requirements.
- Once selection has been made, insert discharge elbow (supplied) into the rubber discharge pipe protruding from lid of Sani pump, trim rubber connector to size and make connection between discharge elbow and upvc discharge pipe.
- Before securing all connections connect a PVC Ball Valve in the upvc pipe-work as near to the beginning of the pipe-work as possible
- Do NOT install a Non Return Valve (NRV) in the discharge line as the discharge elbow (supplied) incorporates an inbuilt nrv.
- All horizontal pipe-work that follows initial Vertical Lift must run with a constant Downhill gradient of 1:100 MIN (or better) to eventual sewer or vent connection.
- Connection to sewer or vent stack can be made via a 45deg junction or boss-strap fitting.
- If running your discharge pipe-work below the floor level on which the pump is located, ensure you install an Air Admittance Valve (AAV) at the highest point of the pipework, this will eliminate the effect of Syphonage.

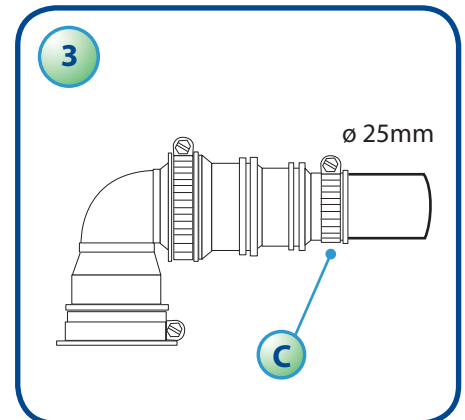
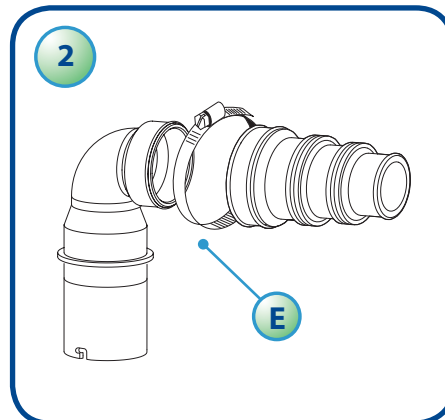
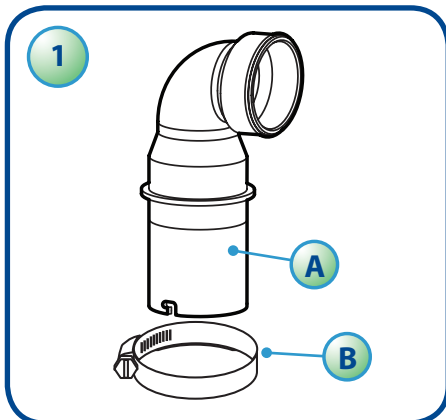

- 1 Insert the elbow (A) into the rubber discharge pipe that rises up through the lid and turn it to the direction required and secure with steel hose clip (B).
- 2 Attach the rubber step down reducer to the discharge elbow and secure with steel hose clip (E).
- 3 Connect to the other end to 25mm uPVC pressure pipe, using steel hose clip (C).

### Connections - Venting

- Where possible venting should always be made in a manner consistent with common plumbing practice venting requirements referred to in Australian Standards AS 3500 10:10 & 6:7:4.
- You can use suitable pvc pipe or plastic hose to run the vent, either to the open atmosphere or to an existing vent stack located nearby.
- To allow this to happen, a short spigot with a 15mm ID opening is located on top of the pump lid to allow commencement of your vent connection.

## 7. Electrical connection

**TO BE UNDERTAKEN BY A REGISTERED ELECTRICAL CONTRACTOR IN CONJUNCTION WITH : AS/NZS 3000.2007**



**The electrical installation should be carried out by a registered electrician.**

The Grey Water Pump is equipped with a 3 core electrical cable which contains Earth Active and Neutral wires, it has a three pin moulded plug attachment. All wires in this cable are colour coded in accordance with International colour coding ie BROWN - ACTIVE ( LIVE), BLUE - NEUTRAL, GREEN / YELLOW - EARTH.

- All wiring connections and GPO locations must conform to AS/NZS 3000:2007 requirements.
- Supply must be protected via a 30mA RCD rated at 16amps, located at the switchboard.
- The Grey Water Pump requires a 240V single phase 50 Hz AC power supply.
- If a decision is made to hard wire, then cost to disconnect and re-connect will be at consumers expense.

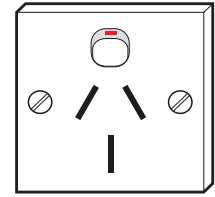

## 8. Commissioning the Grey Water Pump

**BEFORE COMMISSIONING THE PUMP MAKE SURE ALL CONNECTIONS ARE SECURE AND WATER-TIGHT**

Once ALL connections are secure and before you switch the power on, run the cold water tap for approx 10 sec and allow water to enter the pump, this allows the pump to prime. Then switch the power to the pump ON. Your pump should immediately activate and begin discharging into the discharge pipe system. Initial run time is normally between 5 - 10 secs. Duration of run time is generally determined by the length of travel in the pump-out line Pump operation will shut down after this time. Should the pump continue running for longer than the recommended time, an installation or manufacturing problem may exist, immediately contact SANIFLO on 03 9543 3891 and speak with a Tech support person, they will be only too happy to assist.

## 9. Approvals

**The Grey Water Pump conforms to Australian and New Zealand standards AS/NZS and Watermark approvals.**

A lifting plant for waste water NOT containing faecal matter and for limited applications, and to European directives and standards applicable to Electrical and electromagnetic compatibility.

**Saniflo®**

Société Française d'Assainement

**EN 12050-2**

FF02-v35

220 - 240 V - 50 Hz - 400 W - IP44 2.7A -  $\frac{1}{2}$  - 6.3 KG



ATS 5200.101  
Certificate No. 23048  
Manufacturer: SFA  
Brand: Saniflo



## 10. Care and use

**DO NOT...** dispose of solvents, paints, turps, caustic acid, or other corrosive acids or cleaners.

**DO NOT...** dispose of hot water in excess of 60°C.

**DO NOT...** use cleaning products that produce excessive foam, this may cause the pump to cavitate. Cavitation occurs when there is an excessive build up of foam or froth from detergents; this may cause motor damage.

**DO...** dispose of grey waste water ONLY.

**DO...** periodically clean the Grey Water Pump with a basic household detergent cleaner ie domestos, pine o clean or actizyme.

**DO...** consider calling a Service agent, if you experience operational problems at any time eg. pump sounds different than it did during previous operation, sooner rather than later.

### NOISE LEVELS

**All Sani pumps (domestic rated) conform to the National Code of Practice for Noise Management and Protection of Hearing in a workplace or domestic environs (NOHSC 2004-2009)**

All Saniflo Grey Water and Macerator Pumps are not in themselves very noisy and the sound of operation is generally not invasive. However, noise levels can be increased/amplified due to sympathetic resonance from stud partitions, some floors and tight locations.

### Example - decibel comparison

- People conversation (normal) 60-70 db
- Sanipumps (domestic) Max 65 db
- Toilet cistern flushing 75 db
- Vacuum cleaner 80 db

## 11. Servicing

Periodical servicing may be required, depending on your usage cycle. On average we would recommend that a service be undertaken every 2 years or alternatively if you believe that your Grey Water Pump is not functioning as it has been, then give our Technical department a call to obtain details of your nearest Service Agent.

**Saniflo Technical support can be contacted on 03 9543 3891 General Servicing Line Assistance 0400 592 642**

## 12. Warranty

A 2 Yr Manufacturers Warranty applies to your Grey Water Pump this commences from the date of purchase and is subject to CORRECT INSTALLATION and CORRECT USAGE. Any failure or motor burn-out attributed to incorrect installation or consumer misuse is NOT covered under this Warranty.

## 13. Fault Finding / Remedies

For the most part, any inconsistencies in the operation of the unit will be minor and easily rectified. Please refer to the chart below.



**IN ALL CASES, YOU MUST DISCONNECT THE UNIT FROM THE POWER SUPPLY**

**If the problem cannot be easily remedied in this way, please call us on (03) 9543 3891**

**ALL WORK INVOLVING DISMANTLING OF THE APPLIANCE MUST BE CARRIED OUT BY AN APPROVED REPAIR AGENT**

SYMPTOMS	PROBABLE CAUSES	REMEDIES
<ul style="list-style-type: none"> <li>The unit stops</li> </ul>	<ul style="list-style-type: none"> <li>Impeller is jammed</li> <li>The unit has been running for too long and the (self re-setting) thermal cut out has engaged</li> </ul>	<ul style="list-style-type: none"> <li>Call approved service engineer.</li> <li>The unit will reset itself.</li> </ul>
<ul style="list-style-type: none"> <li>The motor intermittently activates</li> </ul>	<ul style="list-style-type: none"> <li>Dripping tap/fixtures</li> <li>The non-return valve is faulty</li> </ul>	<ul style="list-style-type: none"> <li>Check the installation upstream</li> <li>Clean or replace the non-return valve (externally mounted)</li> </ul>
<ul style="list-style-type: none"> <li>The motor operates normally, but continues to run for a long time</li> </ul>	<ul style="list-style-type: none"> <li>The length or height of the installation is over the specification, or there are too many bends/elbows</li> <li>The pump intake chamber is blocked</li> <li>An electrical component has failed</li> </ul>	<ul style="list-style-type: none"> <li>Check the installation</li> <li>Call approved service engineer</li> </ul>
<ul style="list-style-type: none"> <li>The motor does not activate</li> </ul>	<ul style="list-style-type: none"> <li>The electrical power supply is not active</li> <li>The motor or the control system is defective</li> </ul>	<ul style="list-style-type: none"> <li>Restore the electrical supply</li> <li>Call approved service engineer</li> </ul>
<ul style="list-style-type: none"> <li>The motor hums but does not run</li> </ul>	<ul style="list-style-type: none"> <li>The motor or the control system is defective</li> </ul>	<ul style="list-style-type: none"> <li>Call approved service engineer</li> </ul>

## 14. Parts

