



DAVEY
StarFlo[®] AB

Installation and Operating Instructions



 **WARNING:** Failure to follow these instructions and comply with all applicable codes may cause serious bodily injury and/or property damage.

The installation of this product should be carried out by a person knowledgeable in swimming pool plumbing requirements following the installation instructions provided in this manual.

Please install and maintain the products according to AS 3633, AS/NZS 60335.2.41, 3000 standard when the product is used in Australia.

Please install and maintain the products according to EN 60335-2-41 standard and local standard when the product is used in Europe.

The DSF300 can be connected only to a supply with system impedance no more than 0.381 ohm. In case necessary, please consult your supply authority for system impedance information.

Please pass these instructions on to the operator of this equipment.

Prior to using this pump you must ensure that:

- The pump is installed in a safe environment
- The pump enclosure has adequate drainage in the event of leakage
- The pipe-work is correctly sealed and supported
- The pump is primed correctly
- The power supply is correctly connected
- All steps have been taken for safe operation

Appropriate details for all of these items are contained in the following Installation and Operating Instructions. Read these in their entirety before switching on this pump. If you are uncertain as to any of these Installation and Operating Instructions please contact your Davey Dealer or the appropriate Davey office as listed on the back of this document.

Your Davey StarFlo AB Pool Pump

Congratulations on your purchase of a quality product from the Davey range of Pool equipment. You are assured of many years of reliable and efficient performance from your Davey StarFlo AB pool pump backed by Davey's two year guarantee.

The Davey StarFlo AB pool pump has been designed to circulate swimming pool water in conditions set out in the Australian Standard for swimming pool water quality (AS 3633) or equivalent, or use local swimming pool water quality standard when sold in Europe. They should not be used for any other purpose without first consulting your Davey Dealer or the Davey Customer Service Centre.

Every Davey StarFlo AB pool pump is thoroughly tested against a number of pressures, voltage, current and mechanical performance parameters. Davey's advanced pump manufacturing technology provides reliable and efficient pumping performance that lasts and lasts.

THIS APPLIANCE CAN BE USED BY CHILDREN AGED FROM 8 YEARS AND ABOVE AND PERSONS WITH REDUCED PHYSICAL, SENSORY OR MENTAL CAPABILITIES OR LACK OF EXPERIENCE AND KNOWLEDGE IF THEY HAVE BEEN GIVEN SUPERVISION OR INSTRUCTION CONCERNING USE OF THE APPLIANCE IN A SAFE WAY AND UNDERSTAND THE HAZARDS INVOLVED. CHILDREN SHALL NOT PLAY WITH THE APPLIANCE. CLEANING AND USER MAINTENANCE SHALL NOT BE MADE BY CHILDREN WITHOUT SUPERVISION.

DO NOT DISPOSE OF ELECTRICAL APPLIANCES AS UNSORTED MUNICIPAL WASTE, USE SEPARATE COLLECTION FACILITIES.

CONTACT YOUR LOCAL GOVERNMENT FOR INFORMATION REGARDING THE COLLECTION SYSTEMS AVAILABLE.

IF ELECTRICAL APPLIANCES ARE DISPOSED OF IN LANDFILLS OR DUMPS, HAZARDOUS SUBSTANCES CAN LEAK INTO THE GROUNDWATER AND GET INTO THE FOOD CHAIN, DAMAGING YOUR HEALTH AND WELL-BEING.



Davey StarFlo AB Pool Pump – Hydraulic Performance:

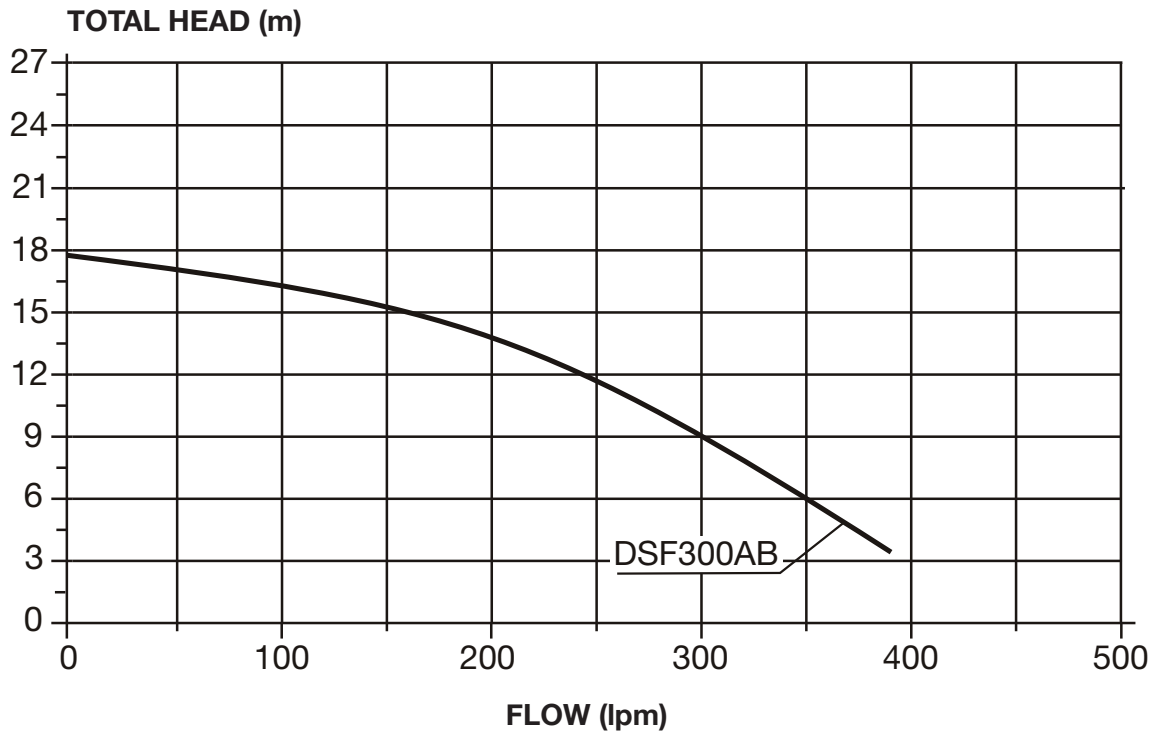

| Model | Q _{MAX} (L/min) | H _{MAX} (m) | Power (P ₁) | | Power (P ₂) | | Amps | Net Weight (kg) |
|----------|-----------------------------|-------------------------|-------------------------|-----|-------------------------|-----|------|--------------------|
| | | | kW | HP | kW | HP | | |
| DSF300AB | 383 | 18 | 1.1 | 1.5 | 0.75 | 1.0 | 5.8 | 10.0 |

Location

The pump should be located as close to the water as practicable and mounted on a firm base in a well-drained position, high enough to prevent any flooding. It is the installer's responsibility to locate the pump such that the nameplate can be easily read and it can be readily accessed for service. The four holes in the base shall be fixed on the ground (alternatively, this can be with a rubber pad and/or mounting frame) after installing the pump.

Weather Protection

It is recommended that the pump is protected from the weather.

Power Connection



IMPORTANT INFORMATION: Your Davey pump is Double Insulated to Water Circuit. If equipotential bonding structure is required, then a Equipotential Bonding Point is provided. (Please refer to AS/NZ 3000 Wiring standards when used in Australia, for use in Europe, please refer to your local wiring standard and regulations).

Davey StarFlo AB pool pumps are suitable for connection to a nominal 220-240 volt 50Hz power supply and are equipped with a flex lead and 3 pin plug. If a power outlet is not available within 3 metres of the pump, a 3 pin power point in a safe, dry place may need to be provided by an electrician. Extension cords are unsafe around pools – and should be avoided. If the supply cord of this product is damaged it must be replaced.



Davey Water Products recommends that all installations are fitted with earth leakage or residual current protection devices.



CAUTION: In the interest of safety, we advise that all brands and types of pool pumps must be installed in accordance with AS3000 or refer to your local wiring rules or equivalent.



In accordance with AS/NZS 60335.2.41 or EN60335.2.41 we are obliged to inform you that this pump is not to be used by children or infirm persons and must not be used as a toy by children.



Power supply to this pump needs to be through an isolating transformer or RCD, having a rated operating current not exceeding 30mA.



If the pump and filter are located below pool water level, it is necessary to fit isolating valves in the pipe between the pump and the skimmer box and in the return pipe between the pump and the filter.



The fittings on this product are constructed of ABS. Some PVC jointing compounds are incompatible with ABS. Check compound suitability before use.



CAUTION: In order to avoid a hazard due to inadvertent resetting of the thermal cut-out, this appliance must not be supplied through an external switching device such as a timer, or connected to a circuit that is regularly switched on and off by the utility.



WARNING! Ensure that an electrical isolation switch is located with easy access so that the pump can be turned off in an emergency.

Typical installation diagram

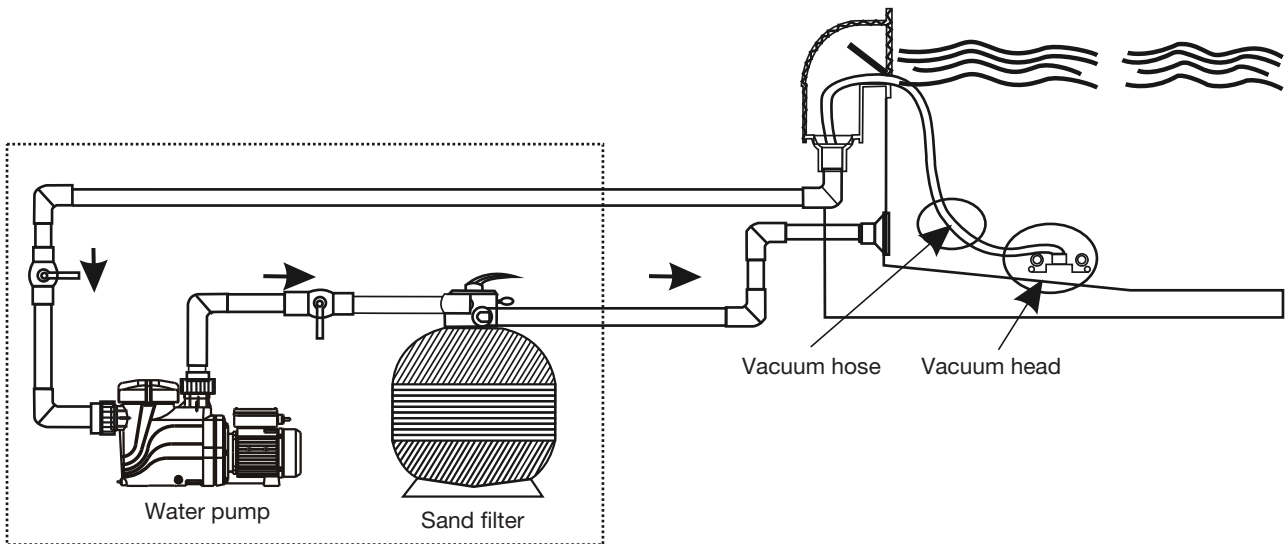

Dimensions

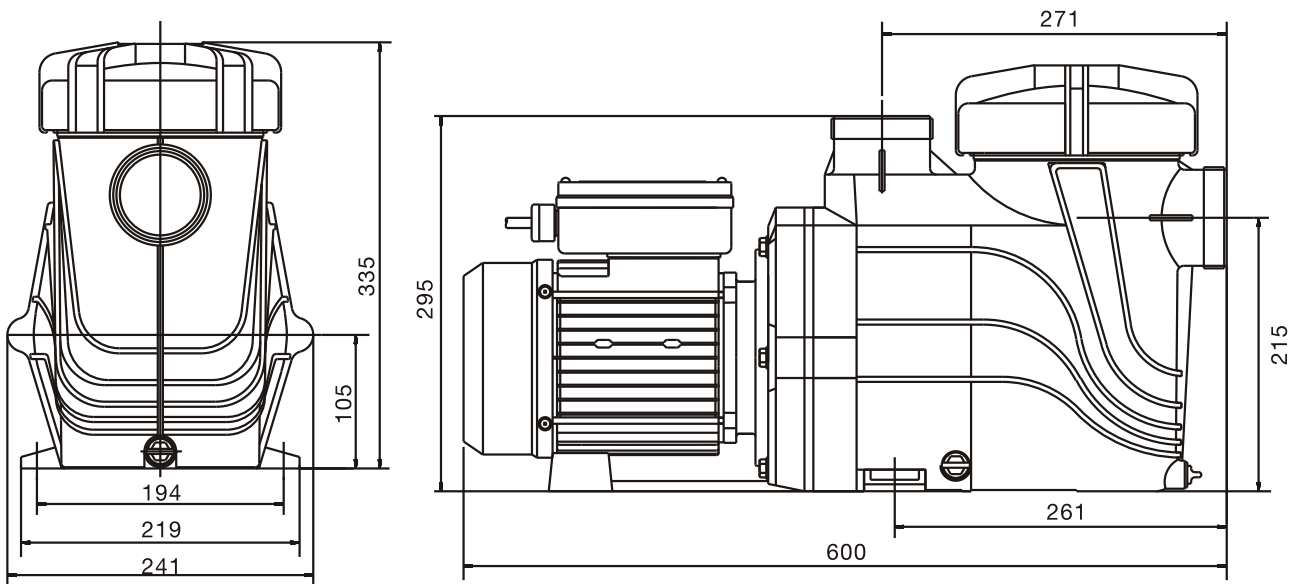

Pipe Connection

A set of 40mm & 50mm barrel unions are provided for connecting to the piping from the pool. The pumps are designed to accept 40mm & 50mm nominal PVC pipe.

The use of any pipe smaller than those specified above is not recommended. Suction piping should be free from all air leaks and any humps and hollows which cause suction difficulties. The discharge piping from the pump outlet should be connected to the inlet connection on the swimming pool filter (usually at the filter control valve).



Barrel unions need to be hand tightened. No sealant, glues or silicones are required.

Starting the Pump

To operate efficiently and prevent pump damage there must be a free flow of water to and from the pump. Before starting ensure that:

- All pipework is correctly sealed.
 - The pool water level is at the correct height.
 - Ensure that all appropriate valves are open and there is nothing preventing the flow of water through the system.
1. When the pump is above the pool water line, first prime the pump by removing the strainer basket lid and filling the strainer basket area with water. Replace the lid, ensuring that it seals on the O-ring.
 2. Connect to the power supply and turn on.
 3. Allow the pump to run, so that any air trapped may be expelled.
 4. If prime is not established within approximately two minutes, as evidenced by a strong flow of water, **turn off the pump and repeat the procedure**. Continued evidence of air under the strainer basket lid indicates an air leak in the suction piping which should be rectified to avoid pump damage.

Pump Operation

For optimum pump performance, the strainer basket housing should always be full of water and free from air bubbles. The water level of the pool should always be maintained to at least

halfway up the skimmer box ensuring water is in the pump at all times. From time to time it may be necessary to re-prime the pump. This should be carried out as described on page 6.



Never run pump dry. Running the pump with no water may damage the mechanical seals, causing leakage and flooding. Dry running damage and associated damage is not covered under warranty. Davey StarFlo AB pool pumps incorporate self-resetting thermal overload, reducing potential damage.

Emptying the Strainer Basket

The strainer basket should be inspected frequently through the transparent lid and emptied when a buildup of rubbish is evident. The directions below should be followed.

1. Turn off pump and unplug.
2. Close all valves in pipework.
3. Unscrew the strainer basket lid anti-clockwise and remove.
4. Remove the strainer basket by lifting upwards from its housing.
5. Empty the trapped refuse from the basket. Hose out with water if necessary.
6. Check the strainer basket for cracks, replace the strainer basket in the pump if OK. Failure to undertake regular maintenance may cause damage not covered by warranty.
7. Replace the lid and ensure that it seals on the rubber O-ring. Firm hand tightness only is required. The O-ring & thread can be lubricated with Hydra slip or equivalent products.
8. Open all valves in pipework.



Failure to undertake regular maintenance may cause damage not covered by warranty.

Trouble Shooting

If the pump runs but there is no water flow or water flow is reduced, the following condition may apply:

1. The filter requires backwashing or it is blocked. Refer to the relevant section in the Filter Manual.
2. The pump is not primed. Re-prime as per instruction in 'Starting the pump'
3. There are air leaks in the suction piping. Check all piping and eliminate leaks, also check for a loose strainer basket lid. Air bubbles in the water flowing back to the pool would indicate a leak in the suction to the pump allowing air to enter the pipework.
4. A leaking pump shaft seal may also prevent operating. Evidence of this would be water on the ground under the pump.
5. The pump is not able to get water from the pool. Check that the valves to the pump are fully open and that the pool water level is halfway up to the skimmer box.
6. Blockage in the piping or pump. Remove the strainer basket and check for any blockage to the pump impeller entry. Check the skimmer box for blockage.

If the pump does not operate, the following conditions may apply:

1. The power is not connected. For 220-240 volt only, check the power point by plugging in a portable appliance to ensure power is available. Also check fuses and the main power supply switch
2. Automatic overload is tripped following an overheating period. The pump has an in-built thermal overload which will re-set after the motor has cooled. Determine the cause of the overload tripping and rectify.
3. Blockage is preventing the pump from rotating.
4. Motor is burnt out – burning smell is evident. Replacement is required.

If you are unable to resolve any installation or operation difficulties with your Davey StarFlo AB pool pump, contact the supplier from whom the pump was purchased. If any further assistance is required, contact the Davey Customer Service Centre at the address indicated in this manual.

The repair, removal and maintenance of the appliance shall be carried out by the manufacturer or the professional personnel of the agent.

Removal of the Pump from Pipework

Should it be necessary to remove the pump, follow these instructions:

1. Turn off the power and remove the plug from the power source.
2. Close the water valves on the pool return and the pump inlet pipework.
3. Remove the discharge & suction barrel unions taking care not to lose the O-rings.
4. Move the pipework with the barrel unions attached until the pump can be pulled clear.



NOTE: When making any enquiries about your StarFlo AB pool pump be certain to quote the model number from the nameplate located on motor.

Water Quality

Maintaining balanced water chemistry is important to the life of your pool pump. This pump is designed to be used with Pool water, balanced in accordance with Langlier Saturation Index, with a pH level of between 7.2 and 7.8 and is regularly treated with a chlorine sanitising agent with the level not exceeding 3.0 PPM.

Please consult your local pool shop regularly to have your water tested.



POWER CONNECTIONS AND WIRING MUST BE CARRIED OUT BY AN AUTHORISED ELECTRICIAN.



WARNING! Pump suction is hazardous and can trap and drown or disembowel bathers. Do not block suction. Do not use or operate swimming pools if a suction cover is broken, missing or loose. Two suction covers and inlets must be provided into every pump to avoid suction entrapment.



Caution! Do not add chemicals directly to the pool skimmer. Adding undiluted chemicals may damage pump and filter and void warranty.



Routine Maintenance tasks – to maximise the life of your pool equipment & personal safety, use this checklist once a week. Turn pump off first.

- a. Make sure that any pressure gauges are in working condition and the operating pressure is within limits as specified on the product.
- b. Make sure that each suction inlet, and main drain has a cover that is securely attached and in safe working condition.
- c. Make sure that all skimmer covers are securely attached and in safe working condition. These should be replaced every 3 to 4 years.
- d. Remove any obstructions or debris from the main drain cover.
- e. Ensure the skimmer baskets and the pump hair and lint pots are free of leaves and debris at least once a week.
- f. Remove obstructions and combustibles from around the pump motor.
- g. Make sure all wiring connections are clean and that all wiring and electrical equipment is in good condition. Damaged wiring must be repaired or replaced by a qualified electrician as soon as damage is discovered.
- h. Check water balance and sanitiser levels at your local pool shop.
- i. Check for sufficient air-flow behind pump – clearance.



DANGER – Hazardous suction. Do not block water entry into filtration system with any part of your body as the pressure can trap hair or body parts, causing severe injury or death. Do not block suction. Turn off pump immediately if someone becomes trapped.

Davey Replacement Guarantee

In the unlikely event in Australia or New Zealand that this Davey product develops any malfunction within three years of the date of original purchase due to faulty materials or manufacture, Davey replace it for you free of charge, subject to the conditions below.

Should you experience any difficulties with your Davey product, we suggest in the first instance that you phone our Customer Service line on 1300 367 866 in Australia, or send a written letter to Davey at the address listed below. On receipt of your claim, Davey will seek to resolve your difficulties or, if the product is faulty or defective, advise you on how to have your Davey product replaced.

Your Davey Three Year Guarantee naturally does not cover normal wear or tear, replacement of product consumables (i.e. mechanical seals, bearings or capacitors), loss or damage resulting from misuse or negligent handling, improper use for which the product was not designed or advertised, failure to properly follow the provided installation and operating instructions, failure to carry out maintenance, corrosive or abrasive water or other liquid, lightning or high voltage spikes, or unauthorised persons attempting repairs. Where applicable, your Davey product must only be connected to the voltage shown on the nameplate.

Your Davey Three Year Guarantee does not cover freight or any other costs incurred in making a claim. Please retain your receipt as proof of purchase; you **MUST** provide evidence of the date of original purchase when claiming under the Davey Two Year Guarantee.

Davey shall not be liable for any loss of profits or any consequential, indirect or special loss, damage or injury of any kind whatsoever arising directly or indirectly from Davey products. This limitation does not apply to any liability of Davey for failure to comply with a consumer guarantee applicable to your Davey product under the Australian or New Zealand legislation and does not affect any rights or remedies that may be available to you under the Australian or New Zealand Consumer Legislation.

In Australia, you are entitled to a replacement or refund for a major failure and for compensation for any other reasonably foreseeable loss or damage. You are also entitled to have the goods repaired or replaced if the goods fail to be of acceptable quality and the failure does not amount to a major failure.



Davey Water Products Pty Ltd
Member of the GUD Group
ABN 18 066 327 517

AUSTRALIA – Head Office

VICTORIA
Customer Service Centre
6 Lakeview Drive,
Scoresby, Australia 3179
Ph: 1300 232 839
Fax: 1300 369 119
Email: sales@davey.com.au
Website: davey.com.au

QUEENSLAND

103 Bancroft Road,
Pinkenba QLD 4008
Ph: 07 3370 3713
Fax: 07 3630 4428

NEW SOUTH WALES

6 Avalli Road,
Prestons NSW 2170
Ph: 02 8777 1122
Fax: 02 8777 1199

WESTERN AUSTRALIA

82 Discovery Drive,
Bibra Lake WA 6163
Ph: 08 9494 0333
Fax: 08 9418 4060

SOUTH AUSTRALIA

54 Pym Street,
Dudley Park SA 5008
Ph: 08 8346 1031
Fax: 08 8342 6574

© Davey is a registered trademark of Davey Water Products Pty Ltd. © Davey Water Products Pty Ltd 2018.



Davey Water Products Pty Ltd
Member of the GUD Group
ABN 18 066 327 517

AUSTRALIA – Head Office

VICTORIA
Customer Service Centre

6 Lakeview Drive,
Scoresby, Australia 3179
Ph: 1300 232 839
Fax: 1300 369 119
Email: sales@davey.com.au
Website: davey.com.au

QUEENSLAND

103 Bancroft Road,
Pinkenba QLD 4008
Ph: 07 3370 3713
Fax: 07 3630 4428

NEW SOUTH WALES

6 Avalli Road,
Prestons NSW 2170
Ph: 02 8777 1122
Fax: 02 8777 1199

WESTERN AUSTRALIA

82 Discovery Drive,
Bibra Lake WA 6163
Ph: 08 9494 0333
Fax: 08 9418 4060

SOUTH AUSTRALIA

54 Pym Street,
Dudley Park SA 5008
Ph: 08 8346 1031
Fax: 08 8342 6574