



**Worry Free Pet Doors**



# Deluxe Aluminium **PET DOOR**

**IMPORTANT! READ AND FOLLOW THESE  
INSTRUCTIONS CAREFULLY AND KEEP FOR  
FUTURE REFERENCE.**

Product Codes:#1162 #1168, #1169, #1170, 1171, 1172

**For installation video, visit:**  
[www.hakunapets.com/deluxe-  
aluminium-pet-door-installation-video](http://www.hakunapets.com/deluxe-aluminium-pet-door-installation-video)



# Parts List

- A. Inner door frame
- B. Outer door frame
- C. Locking cover
- D. 4x Screws
- E. 2x Partition large
- F. 2x Partition small

# Tools Required

- Jigsaw
- Scissors
- Drill with 10mm and 8mm drill bit
- Phillips Screwdriver
- Pencil
- Tape Measure/Ruler
- Duct Tape

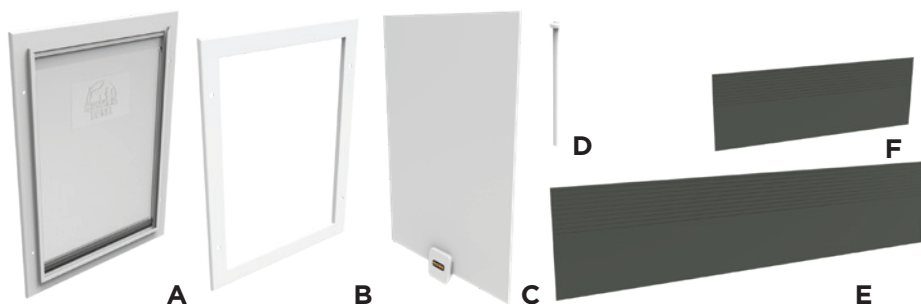

# Installation

**IMPORTANT:** Glass installation only to be completed by a professional glazier.

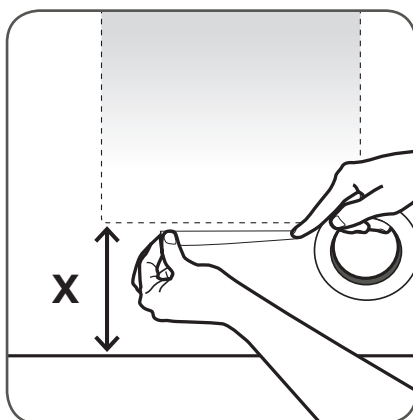
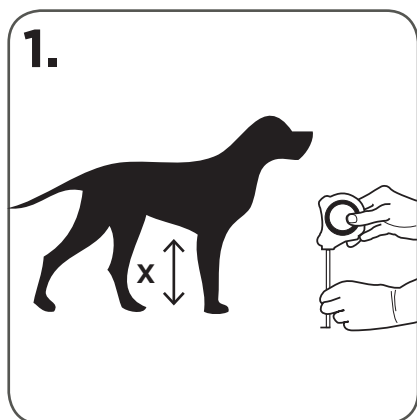

1. Measure the height (x) from the underside of the dog's stomach to the floor. Mark height (x) on door/panel with tape or similar.



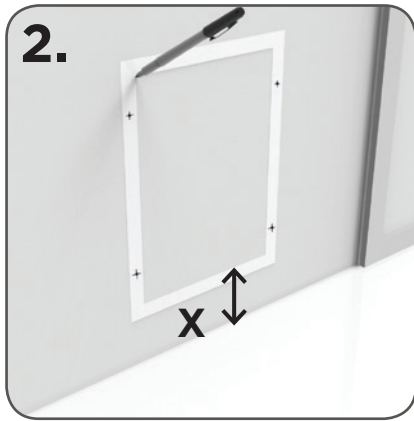

2. Cut out template supplied in box, line up bottom of cut out with height (x) and trace onto door. Mark screw hole positions as well.



3. Drill a hole in each of the 4 inside corners with a minimum of 10mm drill bit.



4. Using a reciprocating jigsaw, cut out the opening, cutting along the pencil outline.

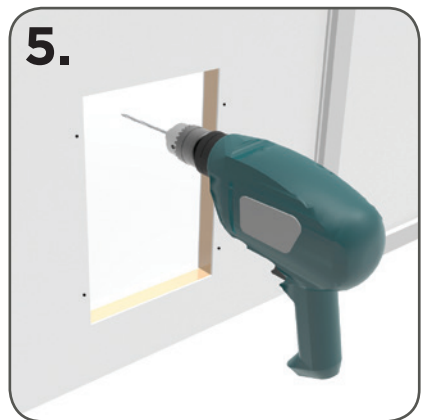

5. Check outer frame fits opening and screw holes align. Drill each of the screw holes using a 8mm bit.

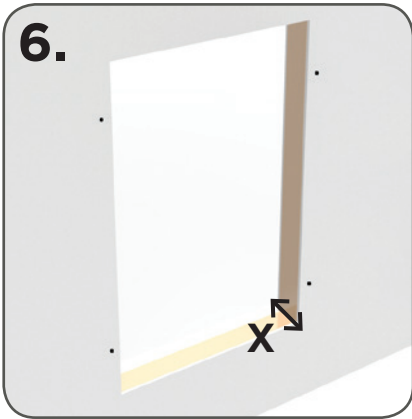

6. Measure the thickness of the door/panel and add 10mm (x) so the tunnel protrudes 5mm on each side. If required, cut partitions down to correct size.

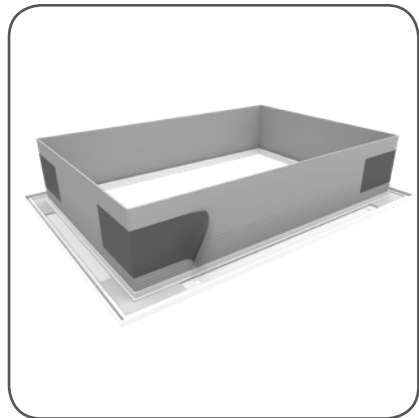
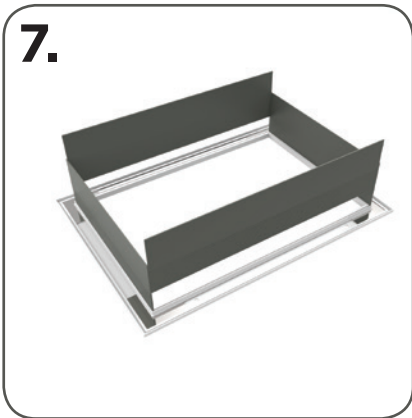

7. Fit all 4 partitions into outer door frame, use duct tape to secure the corners then place into opening.





8. Screw inner door frame into door/panel. Tighten with a Phillips head screw driver. If screws protrude trim the ends to be flush.  
**WARNING:** Over tightening of screws will cause damage.

## Security Screen Installation

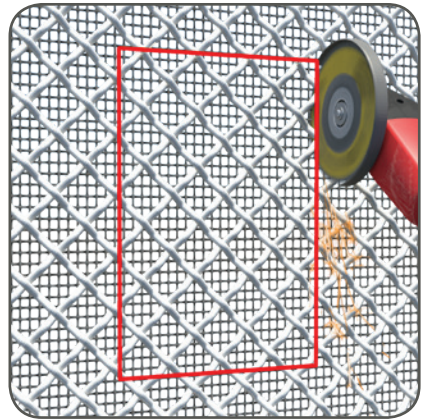
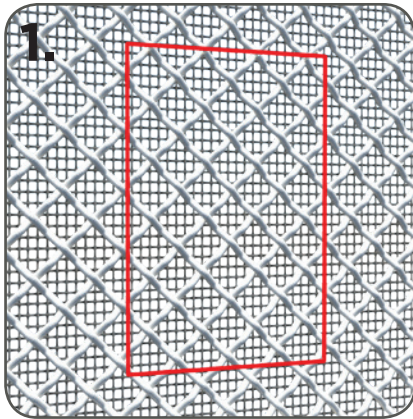

1. Take the measurements needed to cut the opening by following steps 1-3 of the previous instructions. Using an angle grinder, cut out the opening.



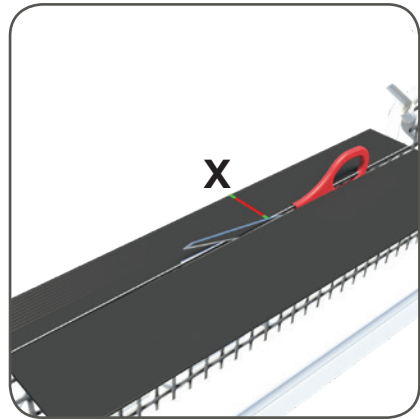
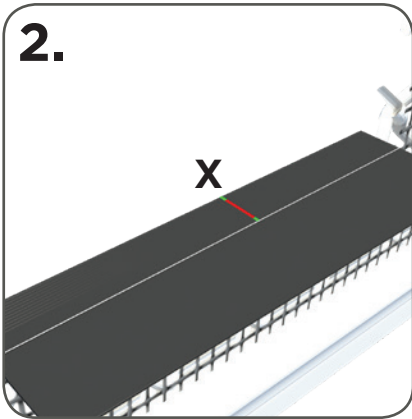

2. Measure the thickness of the door/panel and add 10mm (x) so the tunnel protrudes 5mm on each side. If required, cut partitions down to correct size.

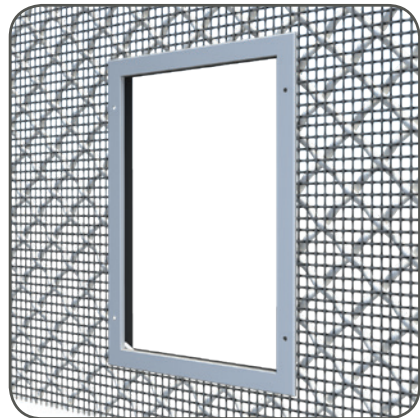
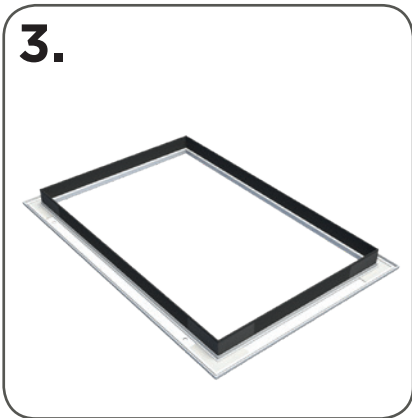

3. Fit all 4 partitions into outer door frame, use duct tape to secure the corners then place into opening.





4. Screw inner door frame into security screen.  
If screws protrude trim the ends to be flush.

## Locking Security Panel

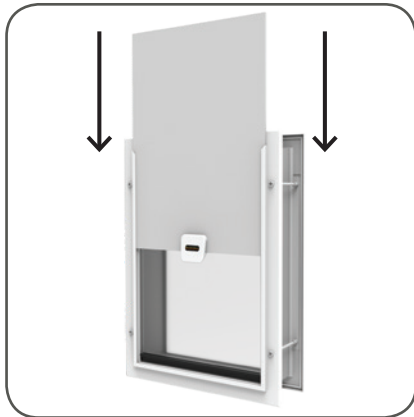

You can control your pet's access using the locking security panel. Simply slide the panel into the channel on the inside frame until latch clips over the bottom of the frame.

# TRAINING

---

1. Use a handful of your dog's favourite treats, get your dog excited about the treats by letting them sniff and lick the treats without actually giving them one.
2. Before starting your training, assess whether your dog would be more motivated to come in through the pet door or go out through it. If your dog loves being inside the house, you should start this training with them outside. If they're always excited to get a chance to get outside, start with them inside the house.
3. With your dog on one side of the pet door and you on the other, lift the flap of the pet door all the way up and call them, using an excited voice and with lots of animation. Wave the treats so they can see them on the other side of the pet door.  
Reward any attempt to come towards or through the door with lots of verbal encouragement, but don't let them have the treat until they make it the whole way through.
4. When they come all the way through, pet and praise them, and give them some treats! Then, leaving them where they are, go to the other side of the pet door, lift the flap and repeat the same exercise. Do a few repetitions going each way then take a break. This training can be stressful and exciting for your dog, so you should do short sessions to avoid burning them out.
5. After your dog has had a break, repeat the exercise. If they're coming through with no hesitation, repeat the exercise holding the flap up only halfway. Your dog may be troubled by feeling the flap touching them, so you'll need to use lots of verbal encouragement to convince them that it's no big deal.
6. Once they're going through with the flap halfway up, continue doing short sessions with them, gradually lifting the flap up less and less, until you're to the point where they're pushing through the door on their own.
7. Now try to get them to do it without you calling and offering them treats. You can do this by leaving them on one side of the door and scattering some treats on the ground on the other side of the door. If your dog comes out on their own, you'll know they're getting the idea. Repeat this for a few sessions, and you'll soon find that your dog is using the pet door on their own.



# WARNING

---

If your home has children as well as pets it is important to remember that children can misuse the pet door and gain access to potential hazards on the other side. You would certainly contravene municipal laws and be found guilty of an offence if there was a swimming pool on the other side of the pet door. You are further advised to be very alert to any future hazards which may occur from time to time on the other side of the pet door such as garden chemicals or insecticides which, even if only put down for a few minutes, would be dangerous to children. Remember that any closing panel or lock provided by Perma Products with this product is for simple convenience and is certainly not a security device. Furthermore we will not be responsible or liable for unintended use or misuse. Please remember it is you the purchaser who must at all times be aware of what you have allowed access to by the installation of this pet door. Please think safety and remain vigilant throughout the life of this product as it is you the purchaser who is responsible for any oversight this installation creates.

## CAUTION

Before you install this door you must check all your building codes or body corporate rules that could affect the installation of a pet door. You should also check with a qualified builder or trades person that the installation you intend is suitable and safe within the chosen location. This is neither a fire door or security door and it is imperative that you the purchaser consider any risks that may be created both inside and outside after installation of your pet door. Please think safety and don't forget to consider future risks that could be brought about by changes elsewhere on your property.

## NOTE

Keep these warnings and cautions with any other important documents in your home and give them to any new owner, tenant or guest so that they too can be made aware of the responsibilities that come with having a pet door within the premises. Template to used only as guide, ensure all measurements and alignment is correct. Ensure the suitability of location before installation of pet door.



# Warranty Certificate

---

Congratulations! You have made an excellent choice of this quality product. Our commitment to quality also includes our service. Should you, contrary to expectations, experience defects due to manufacturing faults, we will provide you with a warranty against defects as follows:

## Warranty

The product is guaranteed to be free from defects in workmanship and parts for a period of 12 months from the date of purchase. Defects that occur within this warranty period, under normal use and care, will be repaired, replaced or refunded at our discretion. The benefits conferred by this warranty are in addition to all rights and remedies in respect of the product that the consumer has under the Competition and Consumer Act 2010 and similar state and territory laws.

Our goods come with guarantees that cannot be excluded under the Australian Consumer Law. You are entitled to a replacement or refund for a major failure and for compensation for any other reasonably foreseeable loss or damage. You are also entitled to have the goods repaired or replaced if the goods fail to be of acceptable quality and the failure does not amount to a major failure.

## Proof of Purchase

This warranty is valid for the original purchase and is not transferable. Please keep your purchase docket, tax invoice or receipt as the best proof of purchase, and as proof of date on which the purchase was made.

## Extent of Warranty

This warranty is limited to defects in workmanship or parts. All defective products or parts will be repaired or replaced. This warranty does not cover consumable items.

## Normal Wear and Tear

This warranty does not cover normal wear and tear to the products or parts.

## Exclusions

This warranty does not cover:

- Any defects caused by an accident, misuse, abuse, improper installation or operation, lack of reasonable care, unauthorised modification, loss of parts, tampering or attempted repair by a person not authorised by the distributor.
- Any product that has not been installed, operated or maintained in accordance with the manufacturer's operating instructions provided with the product.
- Any product that has been used for purposes other than domestic use.

## To Make a Claim

If a defect in the goods appears within 12 months, you are entitled to claim a warranty, please contact or send all warranty claims to:

Perma Products  
35 Paringa Road, Murarrie  
QLD, Australia  
Phone: 1300 467 068  
[www.permaproducts.com](http://www.permaproducts.com)

When making a return, please ensure the product is properly packaged so to ensure that no damage occurs during transit.

Please provide the original or a copy of the proof of purchase. Also please make sure you have included an explanation of the problem.