



## HERITAGE RANGE MODULAR GARDEN BED

1000<sub>mm</sub> (L) 400<sub>mm</sub> (W) 300<sub>mm</sub> (H)

### IMPORTANT

This heritage timber bed is manufactured from the highest quality cypress heartwood. To prevent discolouration over time it is recommended that once assembled the external surfaces are coated with a quality natural oil or stain.

Before filling the bed with soil, ensure it is square and level.

Be aware that this timber product may splinter so it is recommended that protective gloves are worn during assembly.

### KIT CONTENTS

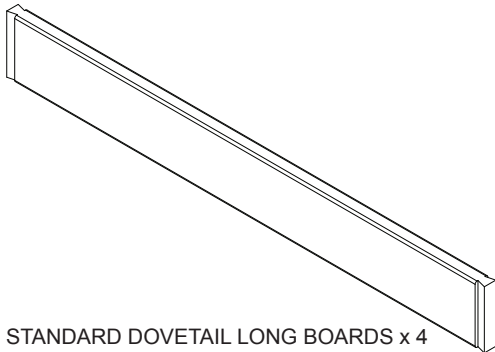

STANDARD DOVETAIL LONG BOARDS x 4

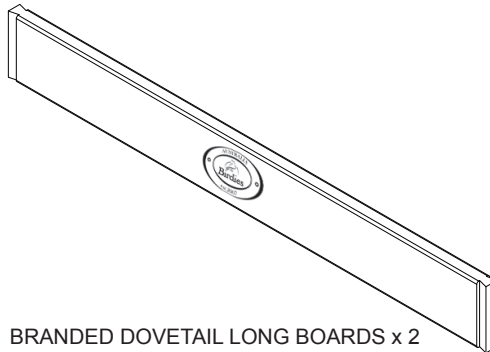

BRANDED DOVETAIL LONG BOARDS x 2

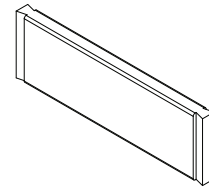

STANDARD DOVETAIL  
SHORT BOARDS x 6

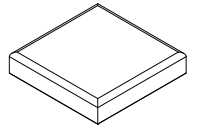

CAPS x 4

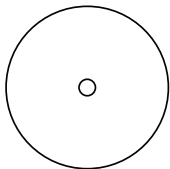

STAINLESS STEEL  
SUPPORT DISCS x 4



WOOD  
SCREWS x 4



HARDWOOD  
DOWELS x 4

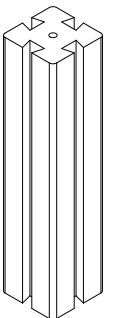

DOVETAIL  
POSTS x 4

### SPECIAL INSTRUCTIONS

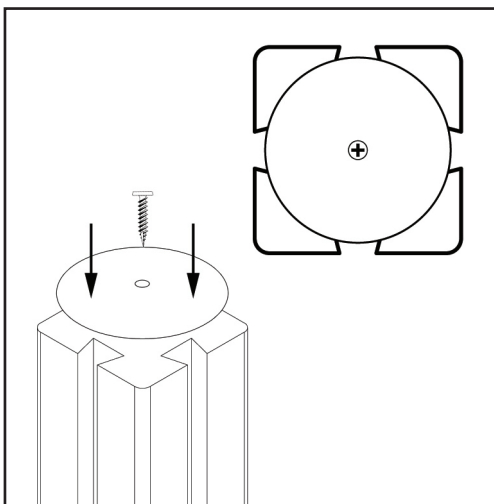

Placing the bed on level ground is advised. Screw the disc to the bottom of the post as shown. Note the larger 8mm hole is the top of the post. The disc is not required on hard level surfaces such as concrete, deck or pavers

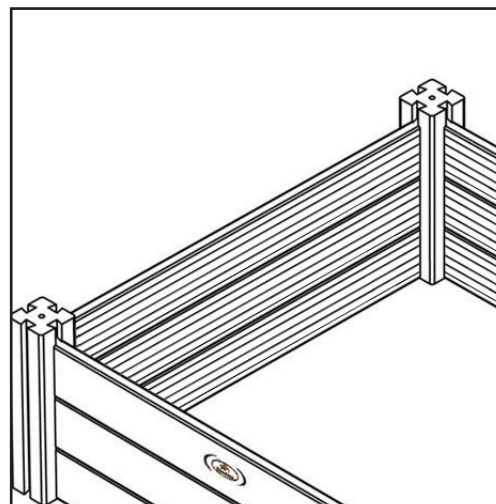

**IMPORTANT**  
The grooved (reeded) side of the timber boards must face inwards.

# ASSEMBLY

## STAGE 01

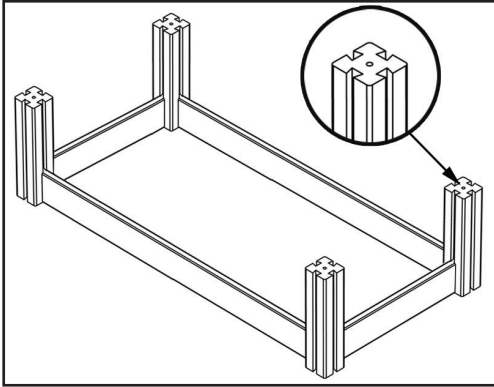

Remove posts and attach discs. Ensuring the 8mm hole is on top slide in the first row of non-branded boards by holding each end of the boards and applying equal force downwards.

## STAGE 02

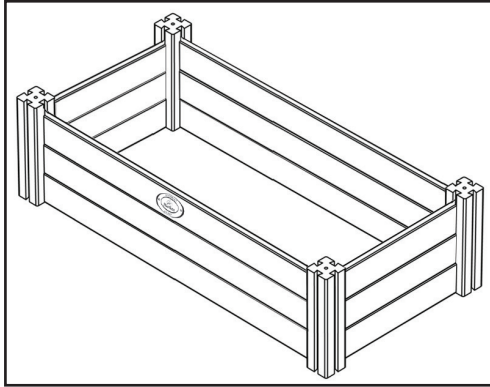

Slide in remaining 8 boards ensuring the Birdies branded long board is located in the top row.

## STAGE 03

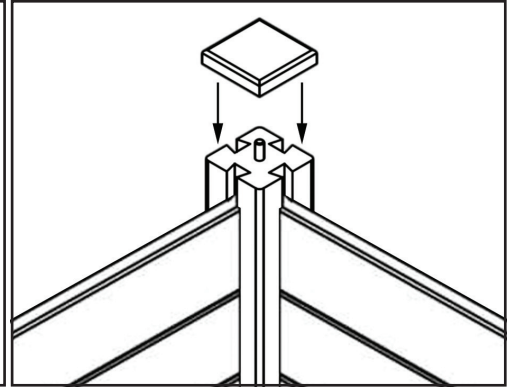

Insert the 4 hardwood dowels into the holes on the top of the posts by hand and then place 4 caps over these dowels. Push down to secure.

### OPTIONAL

Wood glue can be used to fix the cap in place.