

Scandia Avante Open Fire

Model Name

Avante 900

Model Number

SCOF900

Introduction

Congratulations on purchasing a genuine Scandia Wood heater. When cared for properly, these high quality, finely crafted wood heaters will offer many years of reliable performance. This instruction manual has been developed to ensure optimum performance from your Scandia wood heater. It's very important that you thoroughly read and understand all instructions before using your new wood heater.

Check Local Council Requirements Eg. permits

When installing, operating and maintaining your wood heater, follow the guidelines presented in these instructions, and make them available to anyone using or servicing the wood heater. Your city, town, state or territory may require a building permit to install a solid fuel burning appliance.

Always consult your local building inspector or local council to determine what regulations apply in your area.



*Your wood heater **must** be installed by a qualified person whose work conforms with local council regulations, Australian standards & manufacturers recommendations. Failure to do so will void your warranty and could possibly void any home insurance.*

Wood Heater Safety

When properly maintained and operated your wood heater should give you many years of service, however there are important safety aspects of these products that you need to be aware of when operating a wood heater.

1. *This appliance is not intended for use by persons (including children) with reduced physical, sensory or mental capabilities, or lack of experience and knowledge, unless they have been given supervision or instruction concerning use of the appliance by a person responsible for their safety.*
2. *Children should be supervised to ensure that they do not play with the appliance.*
3. *If the electrical supply cord is damaged (if any), it must be replaced by the manufacturer, its service agent or similarly qualified persons in order to avoid hazard.*
4. *Never place combustible items such as but not limited to furniture, fabric or wood within the specified clearances to combustibles.*
5. *The burning of wood gives off gases which can be extremely dangerous. Wood heaters are designed so that under normal operating circumstances these gases pass up the flue chimney system and cannot escape into your home, however it is important that your flue system is properly installed and that you check all joints regularly to ensure that there are no cracks or gaps, check the door sealing rope and replace when damaged. We recommend a smoke alarm be fitted in rooms where wood heaters are installed. Do not use wood heater in a room where negative pressure conditions may occur, such as through the use of extraction fans unless an adequate air supply into the room is ensured, as this may draw air through the wood heater and cause products of combustion to escape into the room.*
6. *This appliance is designed to specifically burn dry hardwood. Do not burn rubbish, driftwood, flammable liquids or any substance containing salts or corrosives.*
7. *Creosote and soot may accumulate in your flue pipe and chimney. This may ignite, causing a chimney fire. If you suspect a chimney fire close down the air controls on the wood heater, if the fire persists evacuate people from the building and call the Fire Brigade. To prevent the accumulation of soot or creosote, check flue and chimney regularly and clean as necessary. Good burning, hot wood heaters will generally cause a lot less build-up than slow burning wood heaters, likewise dry wood will cause less build-up than wet wood. We recommend a fire extinguisher be available where wood heaters are in operation. In the event of a chimney fire do not re-light the wood heater until it and the flue chimney system have been thoroughly checked and repaired as necessary.*
8. *Wood heaters get extremely hot and should not be touched when lit. When young children are in the area, we recommend the use of a suitable fire guard around the wood heaters. Always wear protective gloves when reloading wood heater.*
9. *Never over-fire your wood heater. If external parts of your wood heater are glowing red then the wood heater is over-firing and your draught settings should be reduced. Never interfere with the draught mechanisms or adjust your air settings outside those limits set when the wood heater is manufactured. Never use a fan to supply air to the wood heater or to extract air from it.*
10. *All users of the wood heater should be aware of the contents of this manual. Please leave this manual where it is accessible to wood heater users and do not allow anyone to use the wood heater that is unfamiliar with its correct operation.*
11. *Never use the wood heater if any parts are missing or damaged, only use genuine parts as replacements. Never modify your wood heater.*

Unit Dimensions

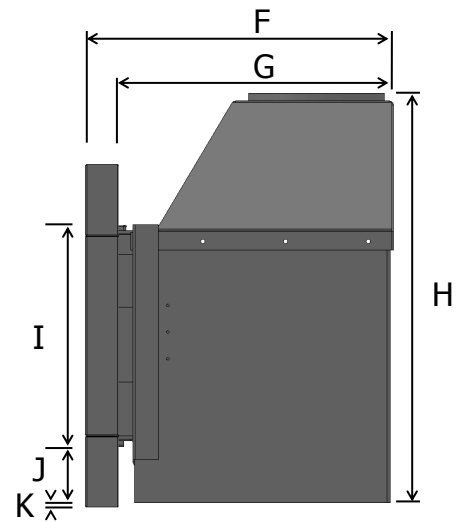
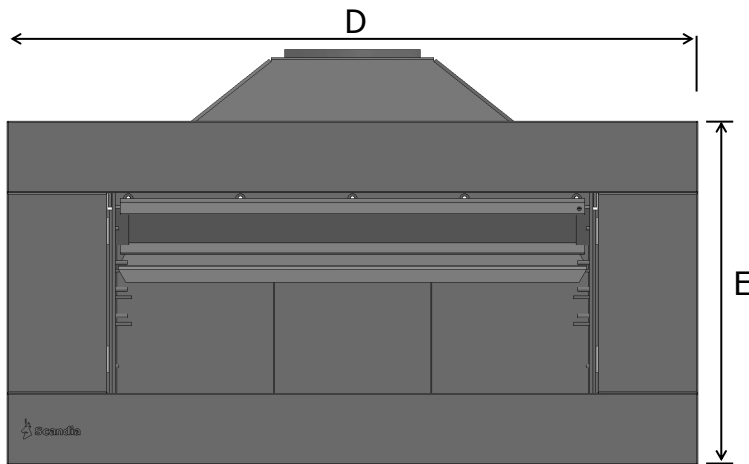
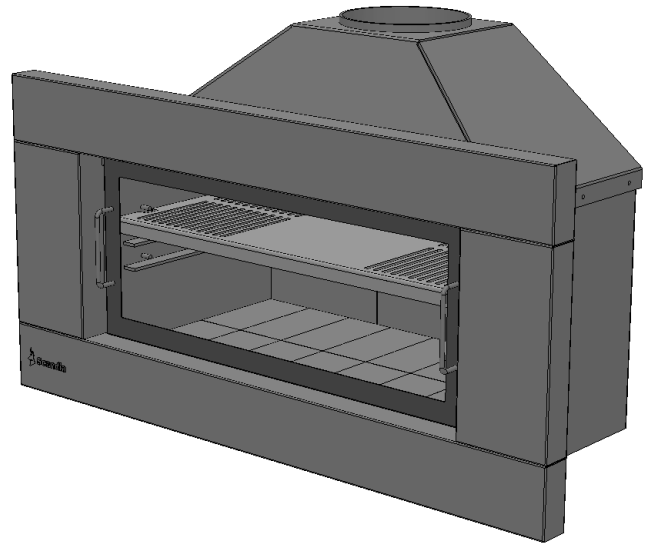
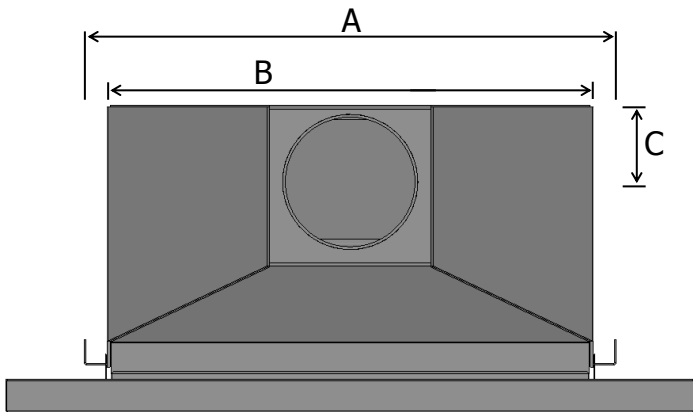

	SCOF900
A – Including front support brackets width	1000mm
B – Firebox width	915mm
C – Rear of firebox to centre of spigot	152mm
D – Facia width	1294mm
E – Facia height	644mm
F – Depth overall including facia	577mm
G – Depth from rear of firebox to front of firebox	515mm
H – Firebox height	770mm
I – Bottom of lower vent to top of upper vent	379mm
J – Bottom of heater to bottom of lower vent	124mm
K – Bottom of facia to bottom of heater	18mm

Before Installing your wood heater

You need to consider the following to ensure the safe operation of your wood heater.

Provision of adequate air to support efficient combustion of the fuel.

A well sealed flue/chimney system, hereinafter referred to as the "flue system".

The protection of combustible materials in proximity of the wood heater.

A suitable base on which to place your wood heater.

Adequate provision air

It is essential for the safe and efficient use of your wood heater that you provide an adequate air supply to your wood heater. This may mean the provision of an outside air supply to the room, especially if there are extraction units such as cooker hoods or clothes dryers in the vicinity. Failure to do so will mean that fuel is burned inefficiently causing smoking glass and may also cause smoke to come back into the room. As a simple check for this open a door or window in the room and check if the wood heater burns more efficiently.

Well sealed flue system

Under no circumstances should you use aluminum or galvanized steel pipes for your wood heater flue.

Always fit pipes with the narrow crimped side down, this allows any creosote to run down the inside of the pipe and not to come out and cause an unsightly mess and possible fire hazard.

Pipe bends should be kept to a minimum and we do not recommend using more than 2 bends on any installation. Flues must not pass through ceilings, floors, attics, roofs, or combustible walls without adequate and approved insulation being provided to protect combustible materials.

The chimney and flue provide a means of taking combusted fuel from the wood heater, as well as a draught to enable the wood heater to work. It is essential that the flue system is kept in good condition and there are no breaks or cracks allowing contact with any other combustible materials of the house. It is also essential that the flue system is kept clean and seals are maintained to ensure the draught is not lost.

The open end of the flue system must be above the height of the apex of the building and any other obstructions, such as trees, which are within 3 meters (10ft) of the flue system. Failure to do this will affect the efficiency of the wood heater and may cause down draughts which will mean dangerous products of combustion are emitted into room.

Under no circumstances should the flue pipe be less than 10" (254mm) internal diameter.

Clearances to combustibles

It is extremely important that you respect required installation distances and that you respect local installation regulations. This is for your safety! The manufacturer is not responsible for the product, if it is not installed following these recommendations. These clearances may only be reduced by means approved by the regulatory authority.

A combustible surface is anything that can burn (i.e. plaster, wall paper, wood, fabrics etc.) These surfaces are not limited to those that are visible and also include materials that are behind non-combustible materials. If you are not sure of the combustible nature of a material, consult your local fire officials.

Hearth requirements

The floor protector must consist of 9.0mm thick bellis board which has a thermal conductivity of 0.1m² K/W, per 9mm thickness or equivalent. Scandia have a complete range of suitable ready to install hearth pads for straight wall and corner installations.

Installation

An air gap of 18mm must be maintained between the floor protector and the base of unit or base of zero clearance box (if used). Use strips of 9mm bellis board (or other suitable non-combustible material) to create 18mm air gap.

The wall must be sheeted with 9.0mm thick bellis board which has a thermal conductivity of 0.1m² K/W, per 9mm thickness or equivalent. This must extend from the bottom of the floor protector to the ceiling and on each side at least 40mm from the zero clearance box or fascia edge when installed.

Zero clearance box sizes and clearances

For more detailed installation instructions please see manual which comes with zero clearance box (ZCB). Only use zero clearance box specially designed for the Scandia Avante 900 wood heater.

The noggin above the zero clearance box must be of non-combustible material.

If not using Scandia Avante Zero Clearance Box, the Avante must be fully encased by non-combustible material.

	SCOF900
A – Front of heater to hearth front	500mm
B – Minimum hearth thickness (non combustible)	9mm
C – Air gap under from floor protector to unit or ZCB	18mm
The following clearances are only applicable when installed with a Scandia Avante Zero Clearance Box. A triple skin (10', 12" & 14") flue kit must be used with ZCB.	
D – Case to side wall	40mm
E – Case to rear wall	25mm

PTO for diagrams

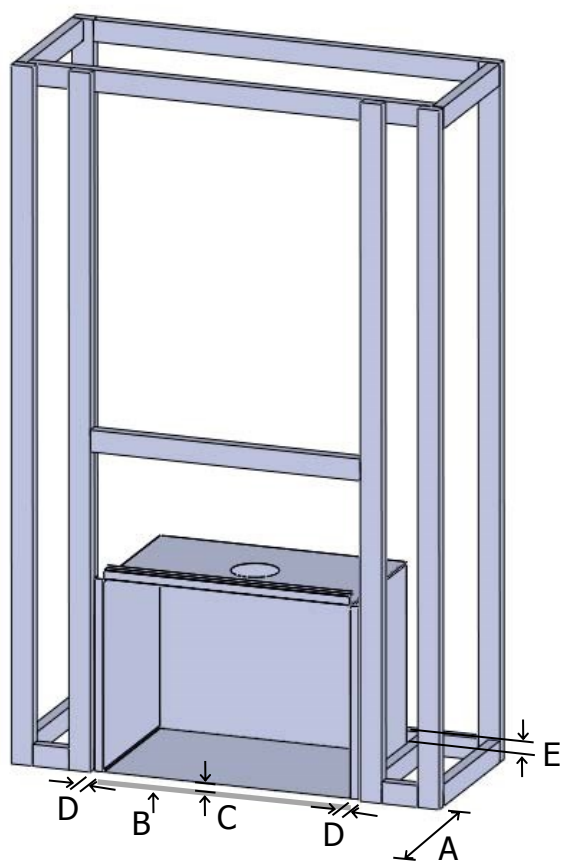
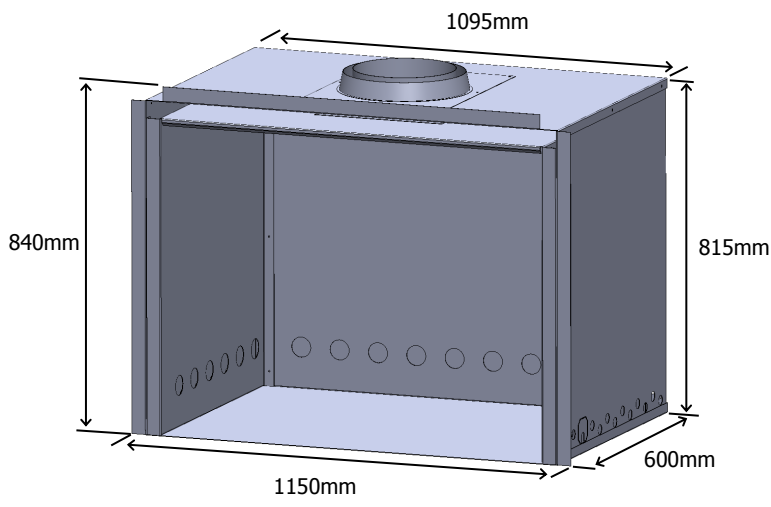

For connecting into existing masonry chimney:

The Chimney should be swept prior to installation. The Chimney must not have any hollow sections present. The connecting flue pipe must be sealed to the chimney with fire cement and high temperature resistant rope as required. This is usually done into a register (Blanking) plate with an access door/hatch to enable chimney sweeping. Flue pipe must continue for the full length of the chimney. The top must be suitably weather sealed with a chimney to flue pipe adaptor sealed in place with mortar. The flue must be completed with a cowl. Note there should not be any flue exposed to the elements.

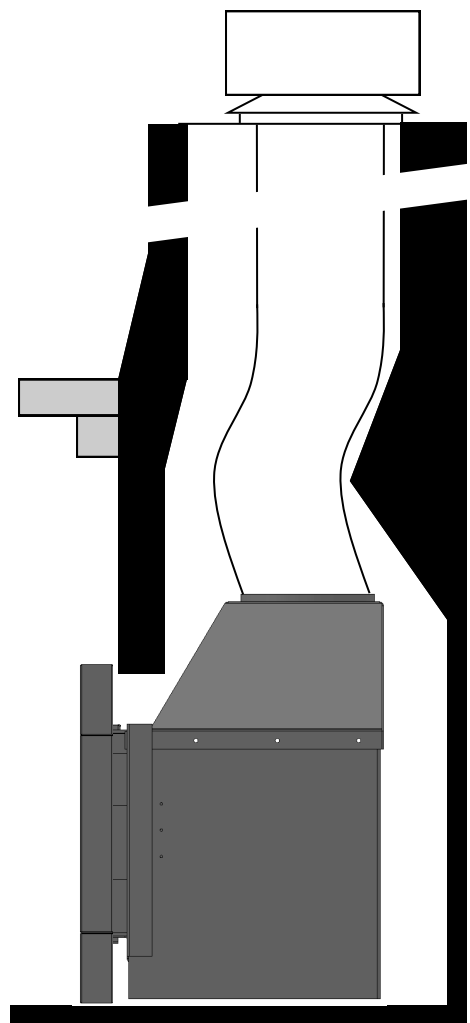

For connecting Scandia 10" ZCB Flue Kit onto a Scandia Avante Zero Clearance Box

The following drawing is meant as a guide only. Your wood heater **must** be installed by a qualified person whose work conforms with local council regulations, Australian/New Zealand standards (AS/NZS 2918:2001) & manufacturers recommendations.

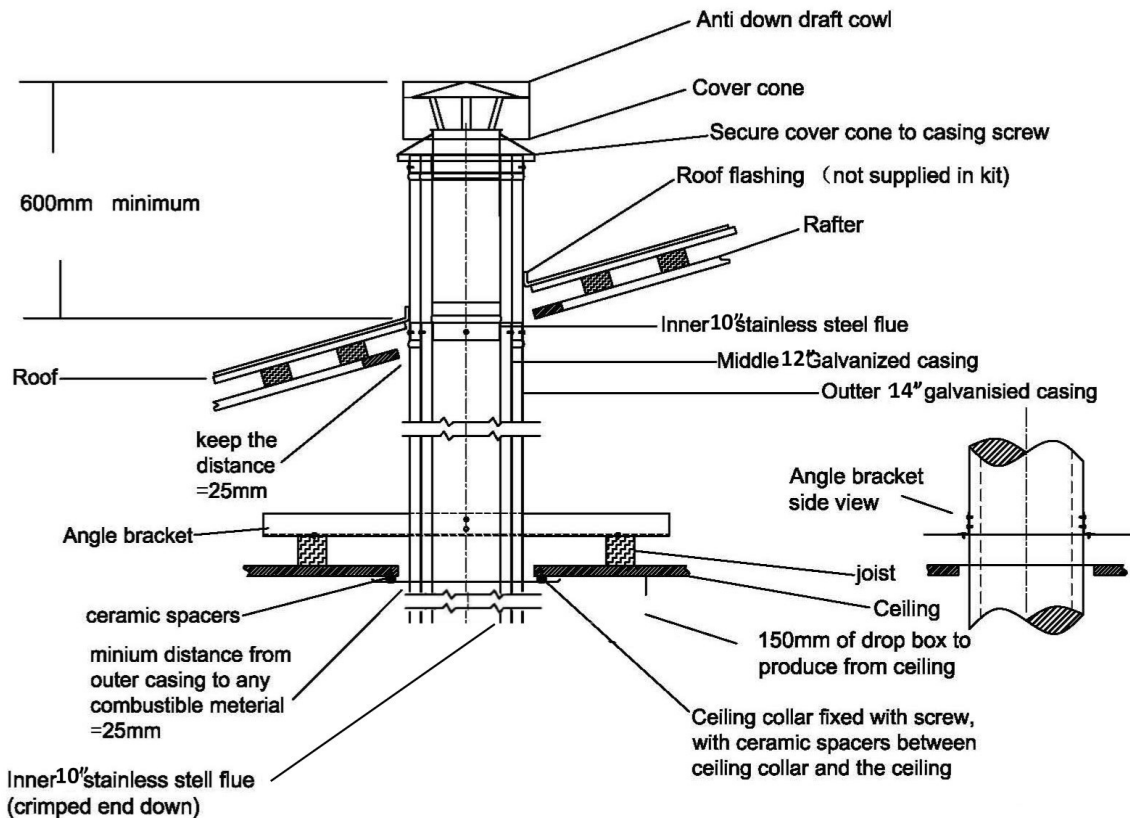

1. Locate wood fire and ZCB in position according to manufacturers recommendations.
2. Check that the outer casing will clear all combustible materials by 25mm. Determine positions of noggins to avoid cutting, otherwise headers must be installed for strength.
3. Using a plumb bob and cut hole in iron to accommodate 14" casing, or remove necessary tiles. If a ceiling is in place cut a 407mm diameter hole in the ceiling. Directly above cut a hole in the roof to accommodate outer casing.
5. Add triple skin sections one at a time. Crimped end down on 10" flue and 12" casing. Crimped end up on 14" casing. Fix each length to the other (of the same size) using stainless steel rivets. Keep a 25mm clearance to combustibles from 14" casing.
6. Add the remaining lengths to the required height. Australian/New Zealand Standards state that "the flue pipe shall extend not less than 4.6m above the top of the floor protector". If the flue pipe is within 3 metres of the ridge, the flue pipe must protrude at least 600mm above the ridge of the roof. If the distance from the ridge is more than 3 metres, the flue pipe must protrude at least 600mm above roof penetration. Additional lengths of casing and flue may be required to achieve this. The flue pipe must be more than 3 metres from any nearby structure. Other clearances may be applicable, it is up to the installer to ensure compliance with all regulations.
7. Install roof flashing (optional accessory).
8. Trim the inner flue to the same height as the outer casing. Place cover cone and cowl over stainless steel flue & push cover cone over gal casing. Fix with stainless steel pop rivets.

Firebox Assembly

Remove all loose items from packaging.

Place flue hood onto firebox and attach with fixtures supplied. Use at least two people with caution as firebox and hood are quite heavy.

Install the three vermiculite panels (330mm x 293mm x 25) in the rear of the firebox. Push rear vermiculite panels together leaving any gaps even on each side. Then install the 16 fire bricks (217mm x 110mm x 25mm) in the base of the firebox as shown in the below diagram. Push base firebricks together leaving even gap around outside.

Install baffle on top of baffle hangers, ensuring baffle plate is pushed all the way back.

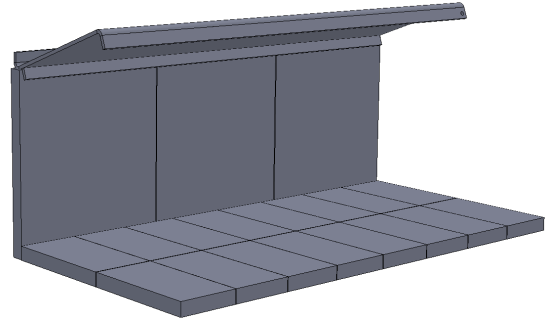

Facia Assembly

Assemble facia as per below diagram ensuring vent holes align. Use fixtures supplied to fix together. Once assembled the facia can be attached to the firebox. Align fastening hooks on facia with slots in firebox side supports, insert fully and push down.

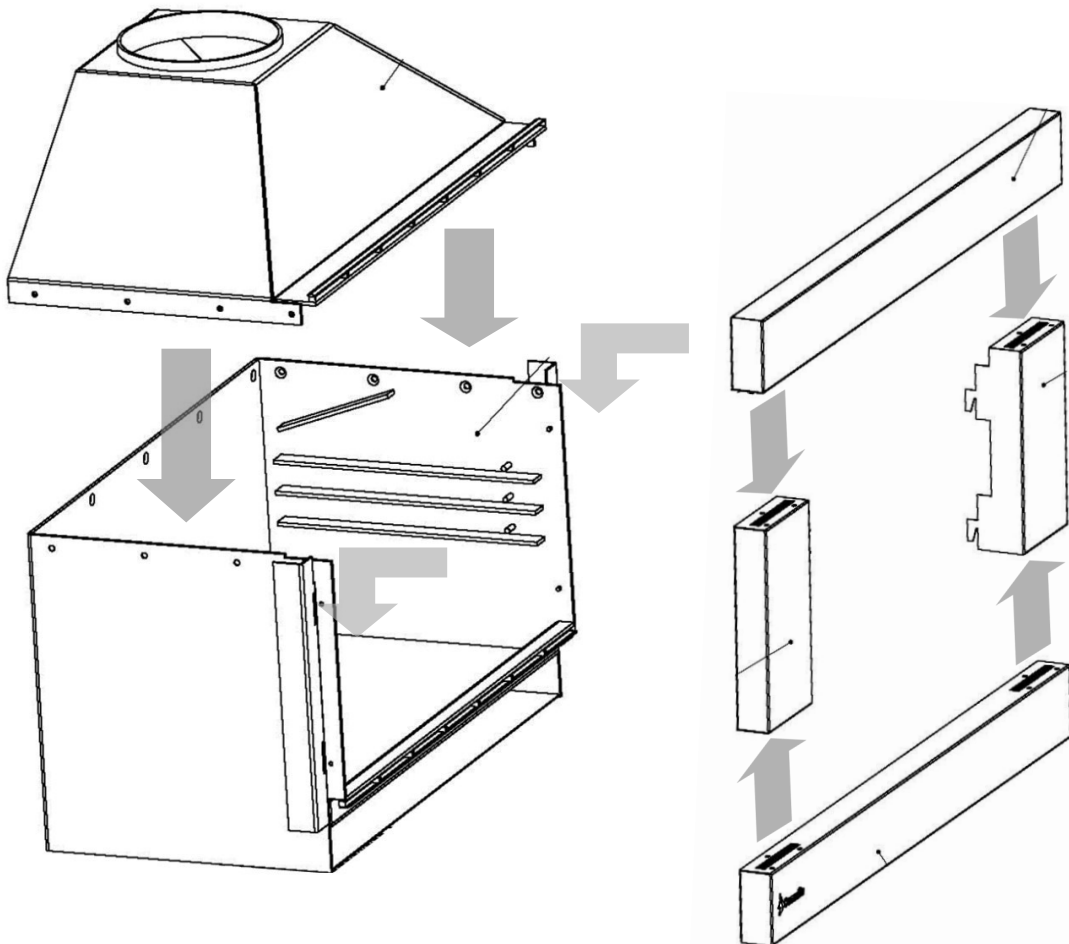

Operating Your Wood Heater

Fuel

Your wood heater is designed to burn dry hardwood only.; it is not designed to burn,

- *Soft wood*
- *Paper or cardboard, other than small amounts used to light stove.*
- *Treated or painted wood*
- *Synthetic fuel or logs that are not approved for solid fuel stoves*
- *Household rubbish*
- *Liquid fuels*
- *Plastics*

Burning these or other products for which the wood heater was not designed may damage the wood heater and cause a fire hazard or release toxic fumes.

Fuel should be stored in a dry place; wood should be dried for at least 1 year and have a moisture content of no more than 20%. Wet wood may cause serious creosote, which may damage your flue system and even your wood heater. Therefore the use of wet wood is strongly discouraged.

First operation of stove

You should begin using your wood heater by lighting small fires which get progressively larger. We recommend lighting approximately 5 small fires before you put the wood heater into full service. Allow the wood heater to fully cool between each of these fires. There may be some smell and a small amount of smoke from the wood heater during the initial operations. This is perfectly normal and is merely the curing of the wood heater paint. Opening a window or door to provide additional ventilation will help alleviate this.

Safety Screen

Your wood heater is supplied with a safety screen. This screen will reduce the risk of sparks emitting from your fire and will also reduce the risk of body parts or items accidentally entering the firebox. The Safety Screen must be in place at all times except for lighting the fire and reloading the fire.

Refueling

To reload the wood heater, remove the safety screen slowly to avoid pulling smoke into the room and feed the fuel in slowly always using the appropriate fire tools along with protective gloves. Do not overfill the wood heater. It is always better to put in small loads often rather than big fills less frequently. Wood should be loaded in a front to back direction, this helps air flow as well as reducing the risk of logs falling forward. Replace the safety screen gently after wood heater is reloaded.

Overnight burning

*Your wood heater is **not** designed to support overnight burning.*

Hot Plate

Your wood heater is supplied with a stainless steel hot plate. Ensure hot plate is thoroughly cleaned before and after use. Store your hotplate under the firebox behind the facia, only remove facia when wood heater is cold. If smoke is entering the room while cooking discontinue use of hot plate feature and take measures to increase flue draw to your heater.

Wood Heater Maintenance

Check your wood heater regularly

Initially, we recommend you check your flue system at least once per month. After the first few months you will notice a pattern of soot and creosote build up and you can then determine an inspection interval for checking soot and creosote build up that is suitable for your wood heater installation.

Other checks, as listed below, should be carried out at least twice per year. If you notice anything wrong at any time it should be repaired immediately. Never use a wood heater that is in any way damaged or has a damaged flue.

- 1. Check your flue system for build up of soot or creosote and for signs of damage to joints.*
- 2. To check flue outlet remove top of baffle by lifting and pulling out at end. Use a flashlight to check flue outlet. Clean and repair as necessary. Always replace top baffle before relighting stove.*
- 2. When the room is dark, use a strong flashlight to check the sealing of the wood heater at the edge and corners for leaks. Any leaks or cracks found should be repaired with fire cement or damaged parts should be replaced with genuine spare parts.*

Ash removal

When the fire is out and completely cold you may remove the ash into a steel bucket with a small shovel. Place a cover over the bucket so that when removing the bucket the ash does not blow about your living area.

Replacing parts

Always use genuine replacement parts. Only ever make replacements when the wood heater is cold. All replacement parts can be ordered from www.scandiastoves.com.au.

Surface finish

Your wood heater should only be cleaned using a damp cloth. Some cleaning products may leave stains on the wood heater surface. Never use abrasive cloths as these may scratch the surface. Painted wood heaters can be re-painted by using a good quality, high temperature wood heater paint. When re-painting, make sure there is plenty of ventilation and follow the manufacturer's instructions. Allow the paint to fully dry before lighting the stove and allow extra ventilation for the first couple of fires as some fumes may emit from the stove as the paint cures.

Stainless steel surfaces may be cleaned using methylated spirits with a clean cloth or specific stainless steel cleaner.

Corten (rusted steel) surfaces may be cleaned using a damp cloth, wiping evenly.

Trouble Shooting

Fire not burning

A wood heater not burning is generally caused by either a shortage of air and/or incorrect or damp fuel. If fuel is not the problem check:

- *There is no blockage in the flue system.*
- *That the open end of the flue is above the height of any nearby obstructions.*
- *That there is a sufficient air supply into the room and that this supply is not being taken by an extractor fan.*

Smoke in room

As an open fire you might expect a small puff of smoke occasionally. However, if the wood heater is properly installed it should not emit any smoke into your room. Should this happen, check that your room is not air tight. This can easily be checked by opening a door or window. If the smoking stops you need to provide an additional air supply into the room. If this is not the problem, check if your chimney is blocked or obstructed and that you are not getting a down draught caused by the location of the open end of the flue pipe or chimney. Environmental factors may require flue height to be increased to alleviate smoke entering the room (eg. Nearby buildings, trees, prevailing winds). If the problem persists contact your dealer and ask him to get your chimney and stove installation checked.

Chimney fire

Chimney fires occur when soot and creosote that have built up in the flue system ignite. If the wood heater is operated properly and the flue checked and cleaned regularly then chimney fires should not occur. These fires can be very dangerous and must be avoided. Try to maintain good, hot fires in the wood heater whenever possible and at least once in every firing open the air controls and allow the wood heater to burn on full for a short while until the entire fire bed is glowing red. Check your flue system regularly for build-up of soot and creosote and clean as necessary. Chimney fires can be detected by sparks coming from the top of the chimney, a roaring sound coming from the area of the stove or chimney or vibration in the stove or chimney. In the event of a chimney fire, close the air controls, evacuate the building and call the fire department. Do not relight the stove after a chimney fire until the stove and flue have been checked and any necessary repairs have been carried out.

Scandia Limited Warranty

This limited warranty (**Warranty**) is given by Scandia Heating (Aust) Pty Ltd (ACN 005 868 093) (**Scandia or we**) to the original retail purchaser (**You**) of the wood heater to which this Warranty applies.

Our goods come with guarantees that cannot be excluded under the Australian Consumer Law. You are entitled to a replacement or refund for a major failure and for compensation for any other reasonably foreseeable loss or damage. You are also entitled to have the goods repaired or replaced if the goods fail to be of acceptable quality and the failure does not amount to a major failure.

The benefits that this Warranty provides are in addition to other rights and remedies available to You under the Australian Consumer Law. This Warranty does not limit those rights and remedies.

IMPORTANT: For this Warranty to apply, You must fully complete the attached card and mail it to our mail address (below) within 30 days after the original purchase. By mailing it to us, You also agree that, to the extent permitted by law, our liability to You on any basis in relation to the wood heater (other than under the Australian Consumer Law) is limited to our obligations under this Warranty.

1. Scope of Warranty

If:

- a defect in material or workmanship appears in the following parts within the corresponding warranty period after the date of the original purchase, such as to make the wood heater unfit for normal home use; and
- You comply with the requirements below regarding making a claim,

then, subject to the exclusions below, we will replace or repair the relevant part or (at our option) replace the entire wood heater with the same or comparable model.

<i>Part</i>	<i>Warranty Period</i>
Firebox	10 years
all other parts (including fans, other electrical items, top baffles, firebrick retainers)	1 year

To the extent permitted by law, our liability under this Warranty is limited to this replacement or repair obligation.

2. Exclusions

This Warranty does not apply:

- *where the defect is not due to the original design or manufacture of the part (including where the wood heater, part or accessory has been subject to accident, abuse, alteration, misuse or neglect or has been installed, inspected, operated or maintained negligently or not in accordance with applicable local laws and regulations and the manufacturer's printed instructions, if any);*
- *where the firebricks, top baffle or fibreglass seal have not been replaced after becoming damaged or worn;*
- *if You are not a retail purchaser, or in the case of non domestic use (e.g. pubs, clubs);*
- *to any accessories or optional parts;*
- *to any glass, paint, firebrick, fibreglass seal sold or used with the wood heater; or*
- *to any surface rust which may occur in transit, storage or use.*

3. How to make a claim

Any claim under this Warranty must be in writing to our mail address below. It must be sent within the applicable warranty period and must state:

- *the model and serial number of the wood heater;*
- *the place, price and date of purchase; and*
- *reasonable details of the defect.*

To obtain replacement or repair under this Warranty, the wood heater must be returned to the original place of purchase (and collected from there once the replacement or repair is complete) at Your cost. Scandia will not be responsible for any associated freight, disconnection or reinstallation costs (including labour costs). Scandia will only be responsible for transport of the wood heater from the original place of purchase to Scandia's premises (and back), and replacement or repair in accordance with this Warranty.

4. Contact details

Our contact details are:

Business and Mail address: 306 South Gippsland Hwy, Dandenong South, Victoria, 3175

Phone: +61 3 5792 2388

Email: info@scandiastoves.com.au