

EXTERNAL BASE DIMENSIONS: 1520mm x 1520mm
EXTERNAL REAR WALL HEIGHT: 1490mm
EXTERNAL FRONT WALL HEIGHT: 1220mm

RECOMMENDED CONCRETE
SLAB SIZE: 1620mm x 1620mm x
100mm THICK

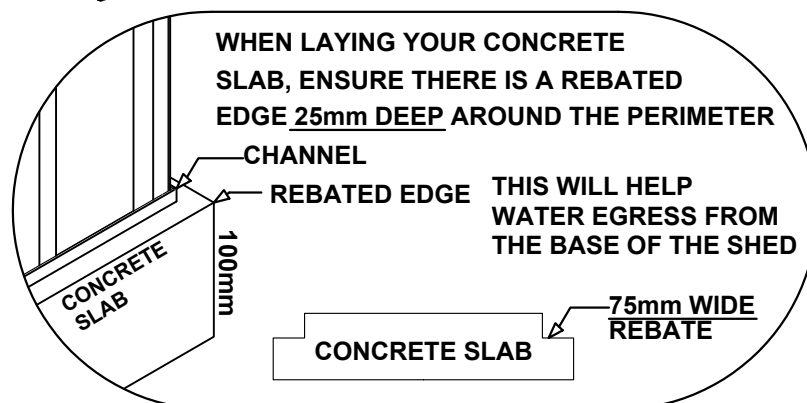

Quality
ISO 9001
SAI GLOBAL



We thank you for choosing an Australian made shed. For further assistance please visit our detailed instructional video library at [Http://www.abscosheds.com.au/watch-videos](http://www.abscosheds.com.au/watch-videos)

At ABSCO Industries we are always looking to be number ONE, so please let us know what you think of our instructions. Feedback makes us better.
feedback@abscos.com.au

GENERAL INSTRUCTIONS

- Before commencing any assembly, read through these instructions in detail to gain a thorough understanding of assembly methods and associated details.
- Unpack the carton and carefully identify and check off all the parts against the parts described and illustrated on pages three and four.

SITE PREPARATION

- The site for the shed must be level. An uneven surface may result in misalignment of parts.
- It is recommended that the shed be set on a 100mm concrete slab and anchored down appropriately (refer to last page for details).
- Anchor sets are not supplied as standard items with this product as some customers wish to use their own anchoring systems.

TOOLS REQUIRED



Normal: 3mm, 4mm & 10mm
Masonry: 10mm

OPTIONAL









A NOTE ON SAFETY

- Some parts may have sharp edges. It is advisable to wear gloves when handling these items and safety glasses if drilling holes. Sensible shoes are highly recommended.
- Do not erect your shed in windy conditions, ensure that the shed is securely anchored to a solid foundation immediately after construction is completed.
- It is highly recommended to erect the shed with two or more people.

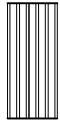
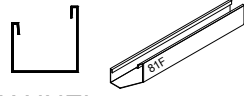
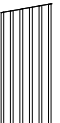
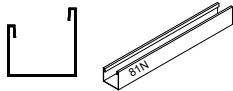
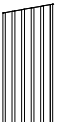

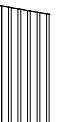
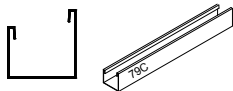
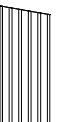
Absco Pool Pump Cover Model: PPCK

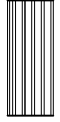
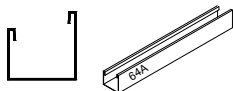
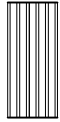
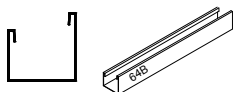
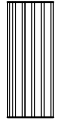
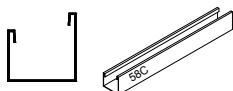
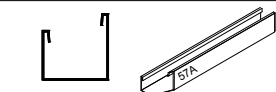
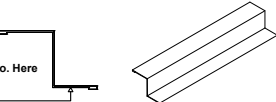
COMPONENTS PACKING LIST - CHECK OFF ALL COMPONENTS

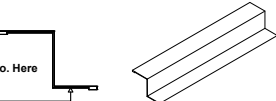
QTY	COMPONENT DESCRIPTION	PART No.	CHECK	QTY	COMPONENT DESCRIPTION	PART No.	CHECK
2	 STEEL SHEET 1460mm X 773mm	PPB		2	 CHANNEL L = 1513mm	81F	
1	 STEEL SHEET 1460mm X 773mm	PPG		2	 CHANNEL L = 1528mm	81N	
1	 STEEL SHEET 1330mm X 773mm	PPL		4	 CHANNEL L = 1513mm	81E	
1	 STEEL SHEET 1460mm X 773mm	PPD		1	 CHANNEL L = 783mm	79C	
1	 STEEL SHEET 1330mm X 773mm	PPR		1	 CHANNEL L = 1200mm	64C	
2	 STEEL SHEET 1622mm X 773mm	PPA		1	 CHANNEL L = 1140mm	64A	
1	 STEEL SHEET 1140mm X 773mm	PPC		1	 CHANNEL L = 1140mm	64B	
1	 STEEL SHEET 1203mm X 711mm	PPF		2	 CHANNEL L = 773mm	58C	
1	 CHANNEL L = 1513mm	57A		1	 Part No. Here JAMB L = 1120mm	91A	
1	 CHANNEL L = 1513mm	53B		1	 Part No. Here JAMB L = 1100mm	94C	

Absco Pool Pump Cover Model: PPCK



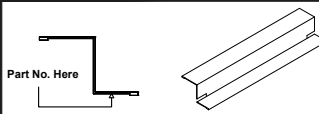
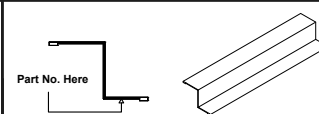
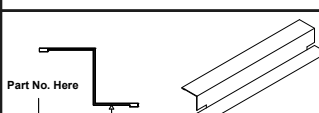
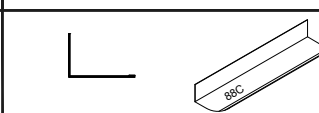
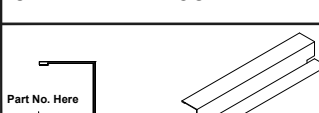
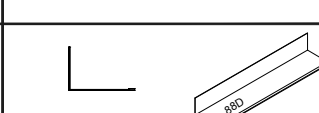

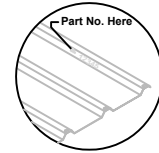

COMPONENTS PACKING LIST (CONT.) - CHECK OFF ALL COMPONENTS

QTY	COMPONENT DESCRIPTION	PART No.	CHECK	QTY	COMPONENT DESCRIPTION	PART No.	CHECK
1	 Part No. Here JAMB L= 783mm	90C		2	 Part No. Here JAMB L= 1480mm	94D	
1	 Part No. Here JAMB L= 1203mm	94A		2	 LIP TRIM L= 1622mm	88C	
1	 Part No. Here JAMB L= 1203mm	94B		4	 LIP TRIM L= 230mm	88D	

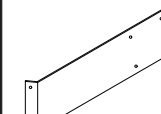
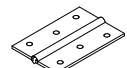
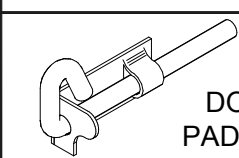
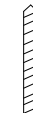
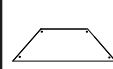
**ALL SHEETS HAVE PART NO.S LOCATED ON
LOWER RIGHT OR UPPER LEFT CORNER OF
COLORED SIDE AS SHOWN**

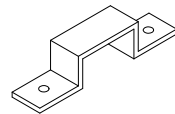

CONTENTS OF FITTINGS PACKET

1	 DOOR STRAP L: 165mm	12A		5	BUTT HINGES 		
2	 DOOR PADBOLT	22A		1	3mm DRILL BIT 		
1	PRE-PUNCHED PADBOLT SUPPORT PLATE 	22C		30	3mm POP RIVETS 		
1	DOOR PADBOLT HASP 			30	CSK SCREW & NUTS 		
100	10mm SELF TAPPING SCREWS 			1	ASSEMBLY INSTRUCTIONS		
5	20mm SELF TAPPING SCREWS 						

VIEW OF ROOF AND WALL COMPONENTS

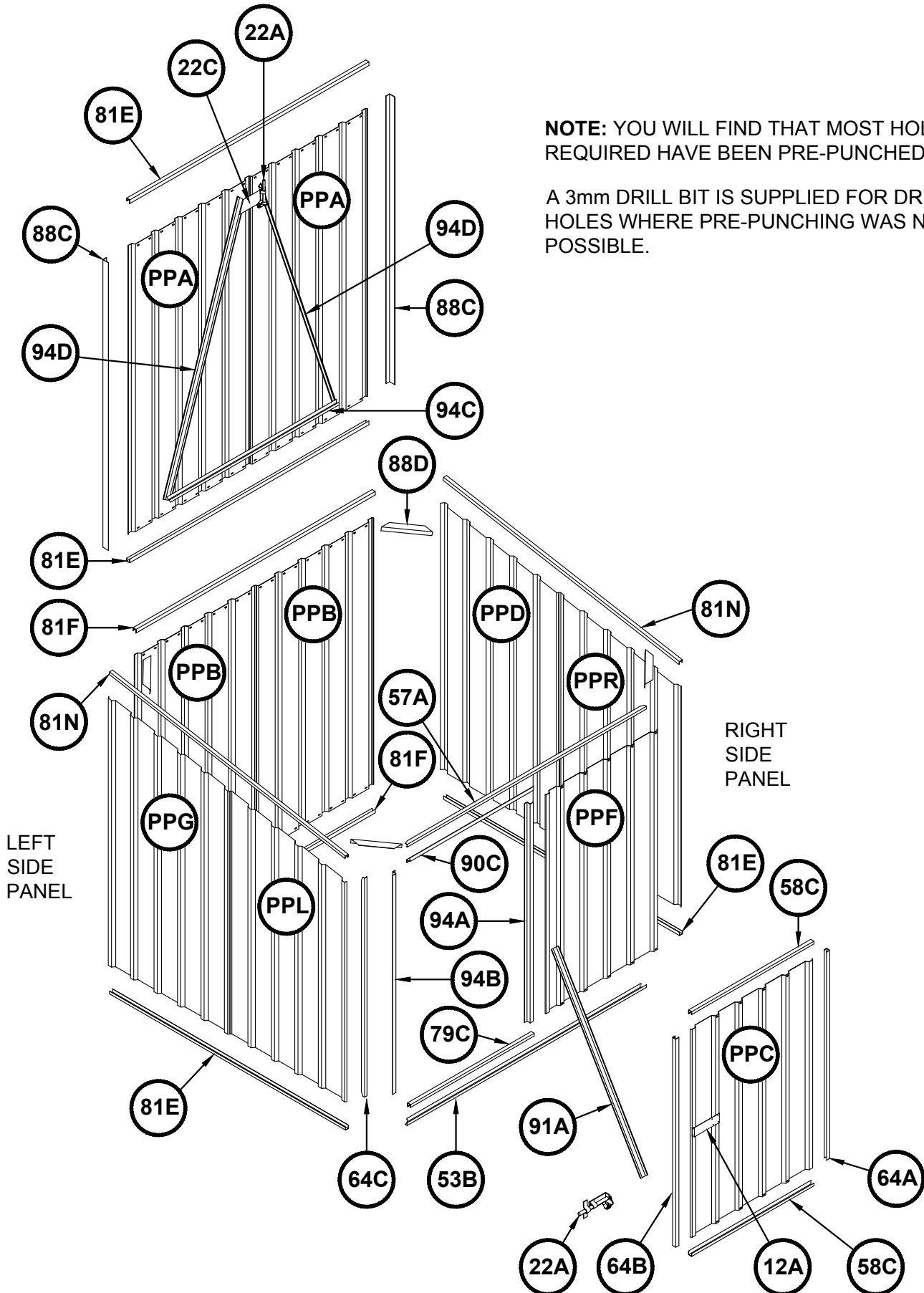

ABSCO ASSEMBLY INTRODUCTION

The snectite assembly system locks most perimeter channels to all roof and wall sheets without the need for tools and fasteners.

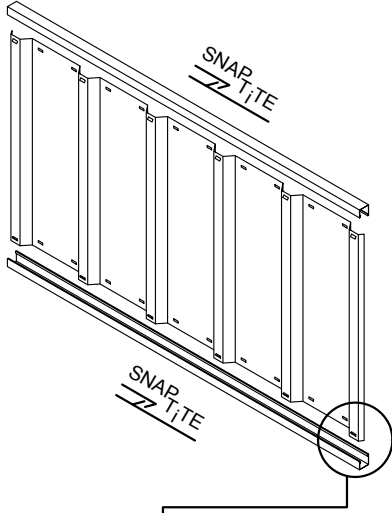

To pre-assemble the four wall panels and two roof panels, the perimeter channels are secured to the top and bottom of each panel using the snectite system, as detailed on the following pages wherever you see the symbol.

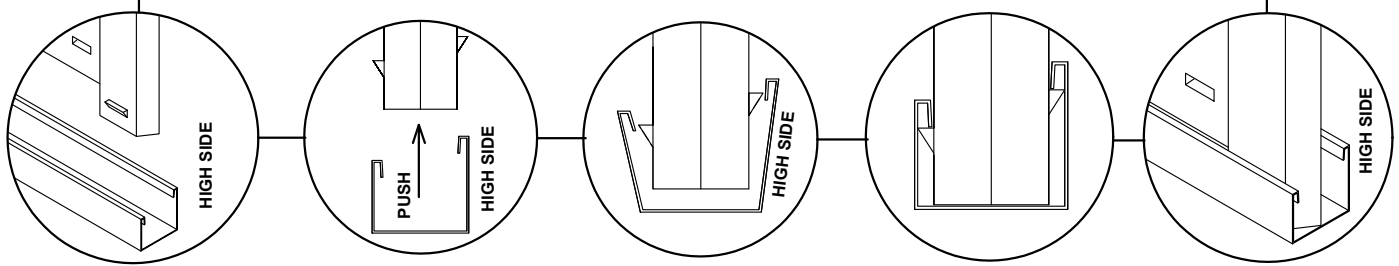
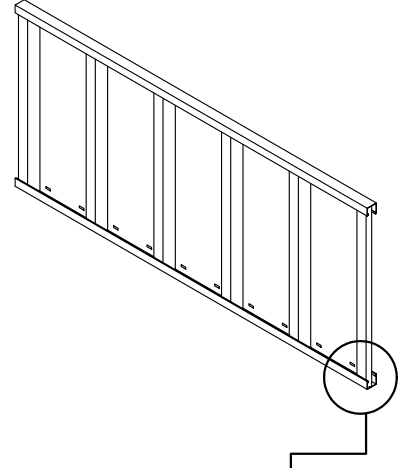

After joining sheets together, position channel over one end of the sheets, gently tapping it over the snectite lugs, working along the sheets to the other end.

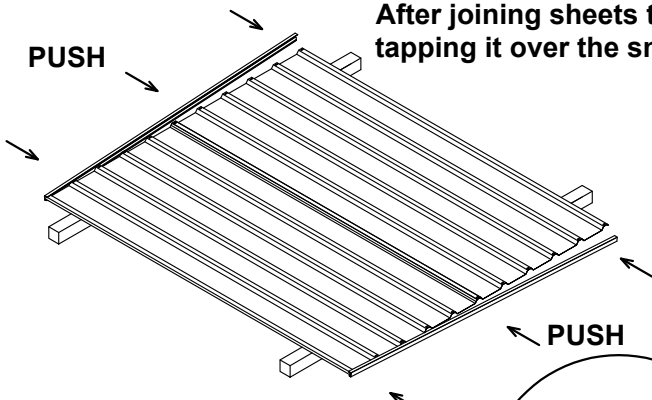

Position sheets on timbers, trestles or partly over edge of concrete slab.

Each perimeter channel must finish flush with the edges of the sheets. The snectite system allows adjustment for this process by simply tapping the channel along the sheets until each end is neatly flush. If you need to remove channels from the panels, pull the channel along the panel from opposing ends. You may need someone to help with this.

FASTENING SYMBOLS

 **D** Join components together by pre-drilling the holes first. Use one component as a template to mark where the holes are. Drill with 3mm drill bit.

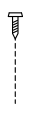
 Join components together with one screw at this location only, as some channel sections have extra holes that are not required for this model of garden shed

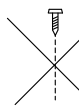
 Do not join components together at this location yet, as the screw may obstruct further assembly of other components

 3mm POP RIVETS

 4mm NUT & BOLT SET

1. REAR PANEL ASSEMBLY

**NOTE: JOIN TOGETHER AT
PRE-PUNCHED LOCATIONS
AS SHOWN.**

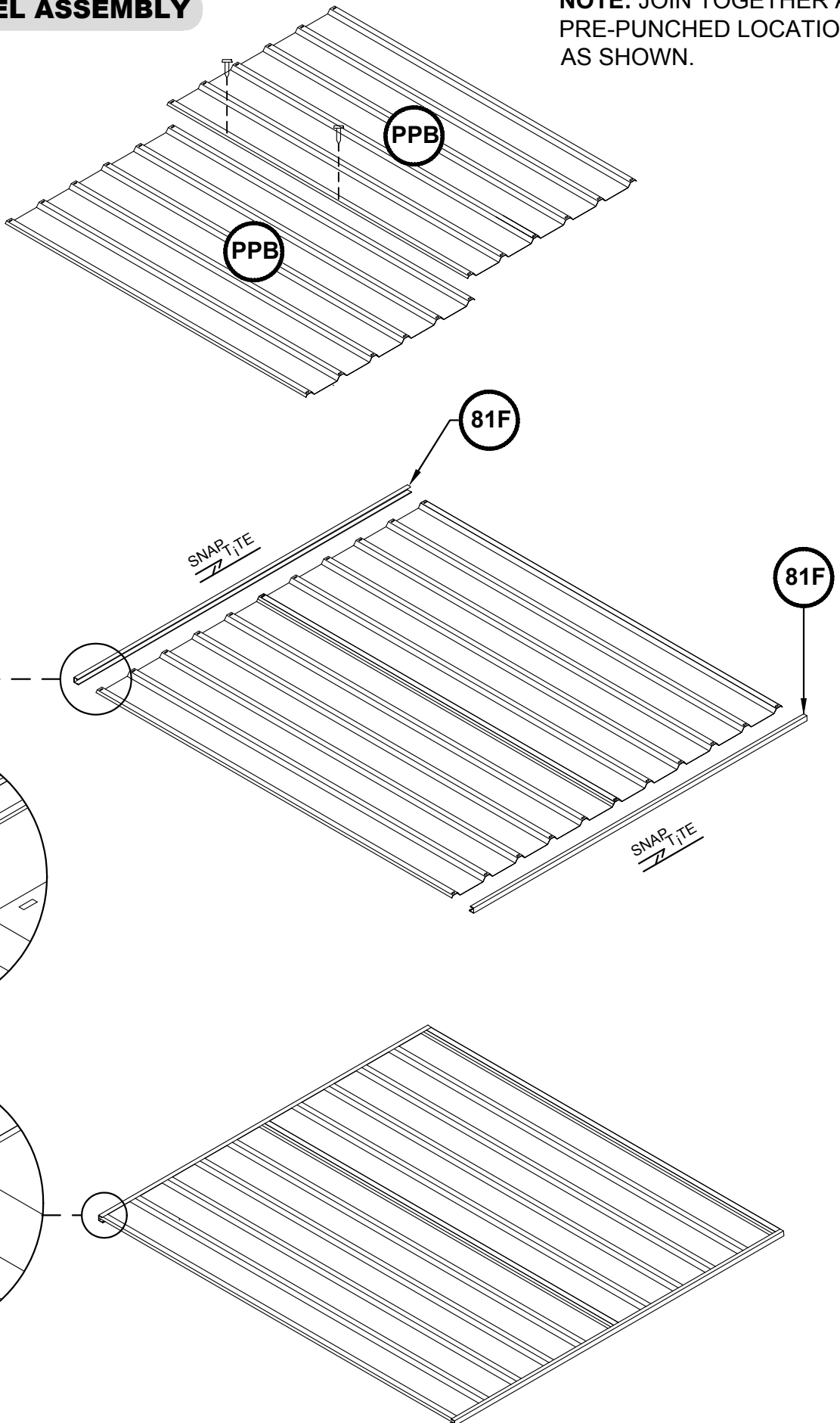

2. LEFT PANEL ASSEMBLY

NOTE: JOIN ALL FIVE COMPONENTS TOGETHER AT PRE-PUNCHED LOCATIONS AS SHOWN.

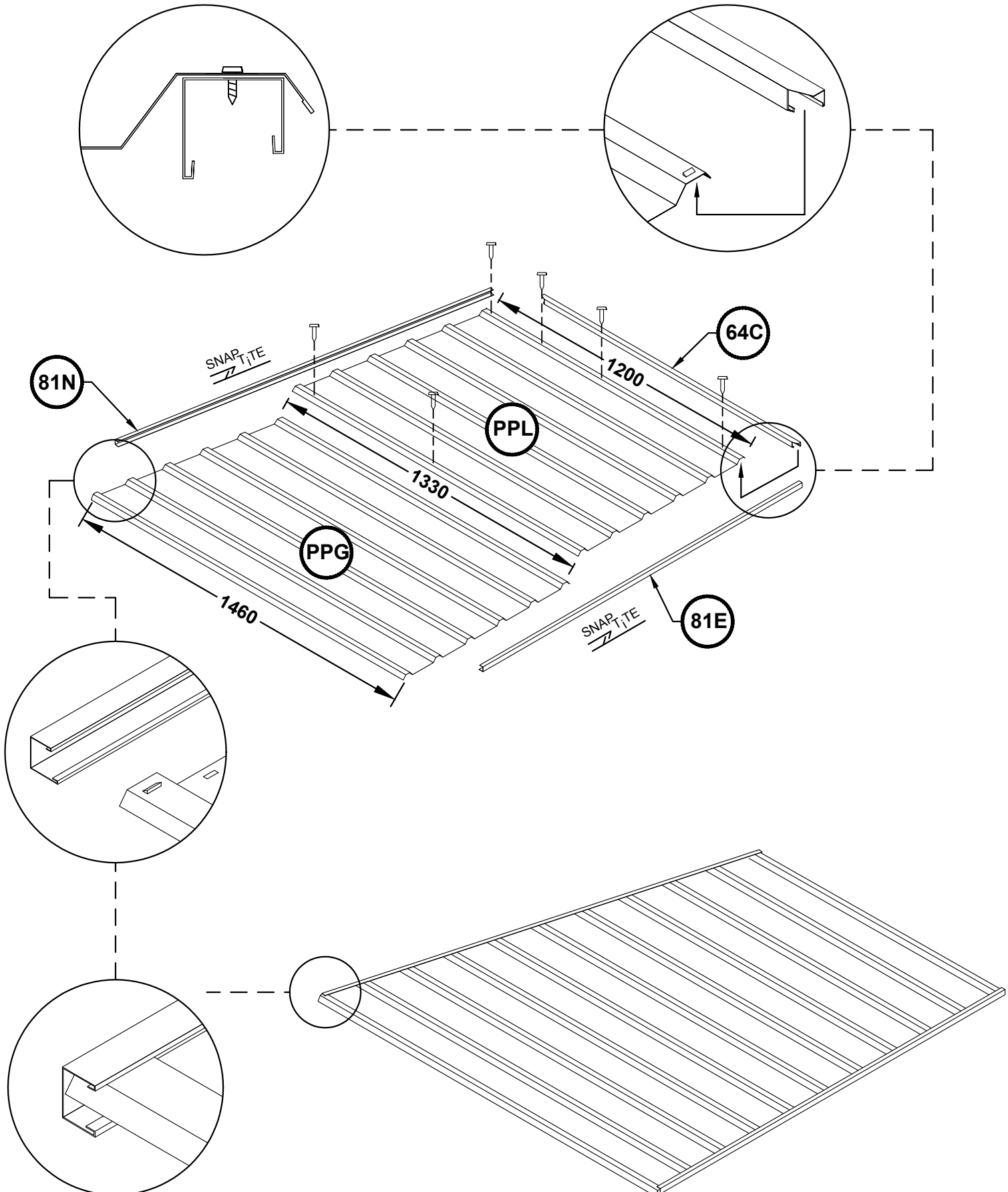

3. RIGHT PANEL ASSEMBLY

NOTE: JOIN TOGETHER AT
PRE-PUNCHED LOCATIONS
AS SHOWN.

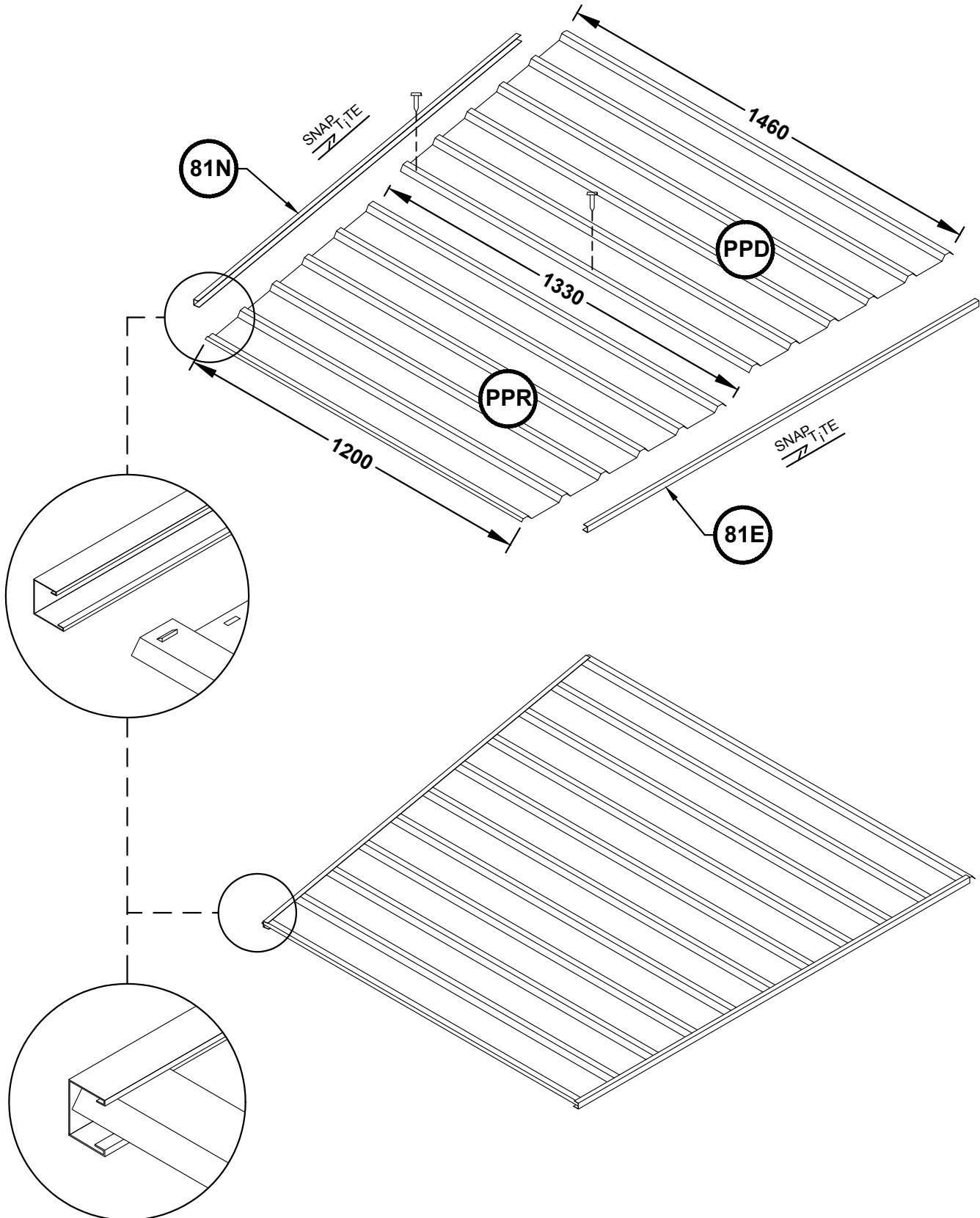

4. LID PANEL ASSEMBLY

**NOTE: JOIN TOGETHER AT
PRE-PUNCHED LOCATIONS
AS SHOWN.**

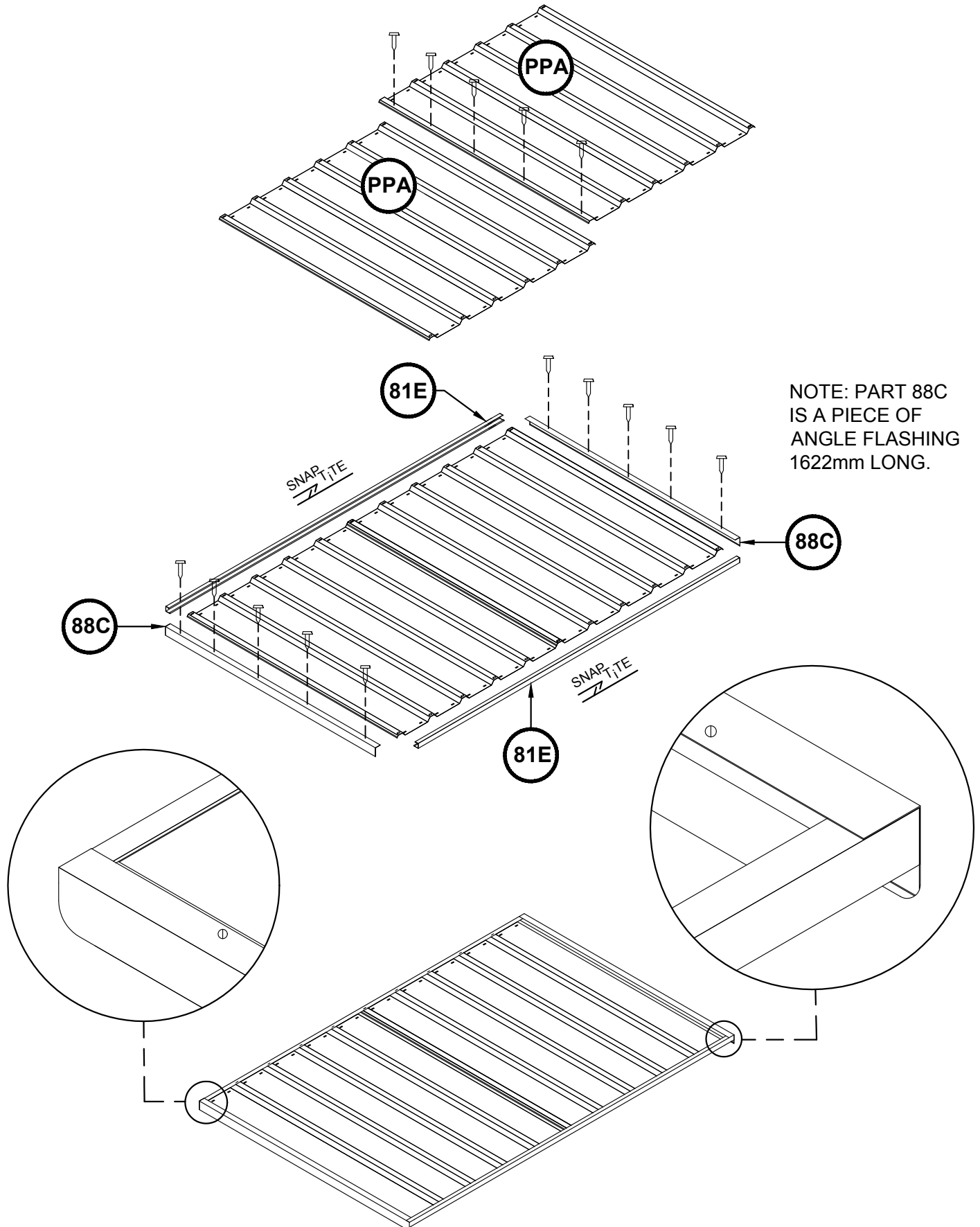

**NOTE: PART 88C
IS A PIECE OF
ANGLE FLASHING
1622mm LONG.**

Absco Pool Pump Cover Model: PPCK

5. FRONT PANEL ASSEMBLY

NOTE: THIS SPECIAL 711 WIDE SHEET MAY NOT BE PRE-PUNCHED WITH SNAP-TITE LUGS IN CERTAIN COLORS, SO DRILL HOLES AND SECURE WITH THREE SCREWS TO THE 57A & 53B CHANNELS.

THIS SHEET MAY NOT BE MARKED WITH A PART NUMBER BUT CAN BE IDENTIFIED BY ITS SIZE OF 711mm WIDE X 1203mm LONG.

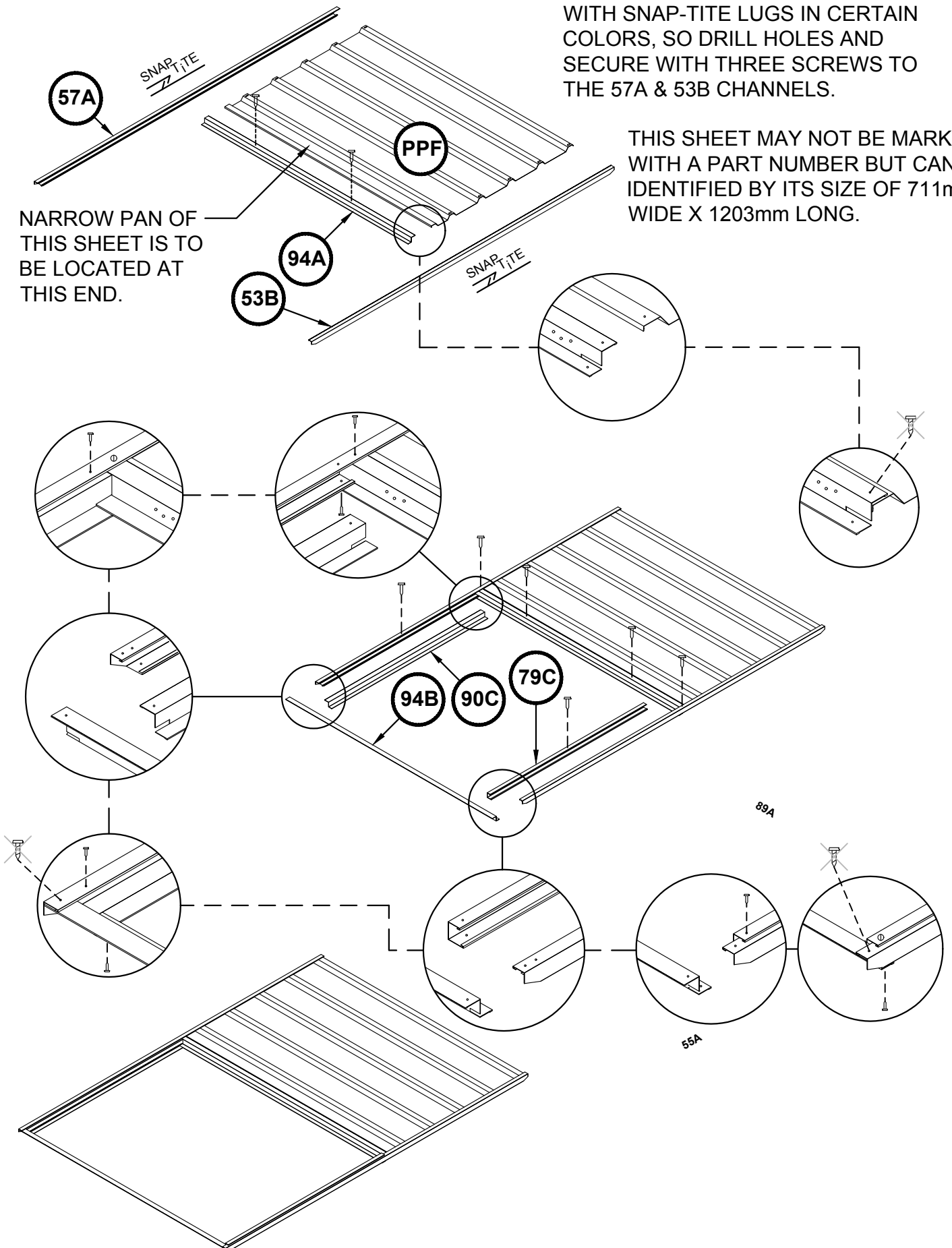

Absco Pool Pump Cover Model: PPCK

6. DOOR CONNECTION

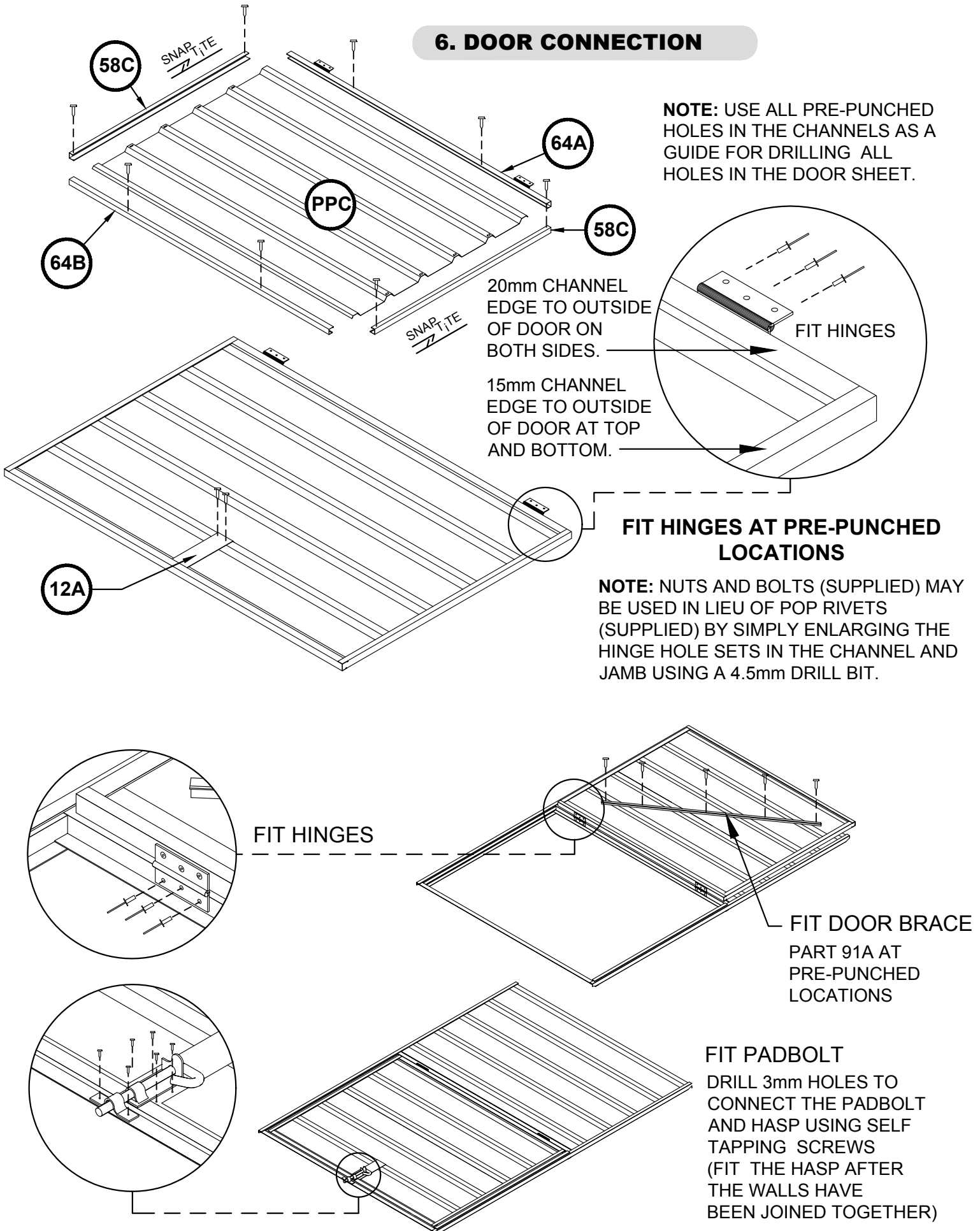

7. JOIN WALL PANELS

NOTE: JOIN THE FOUR WALL PANELS TOGETHER AT PRE-PUNCHED LOCATIONS AS SHOWN.

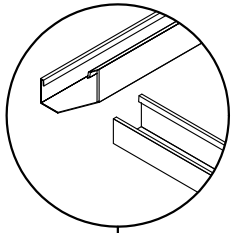

SIDE WALL PANEL CHANNELS FIT INTO THE NOTCHED FRONT AND REAR WALL PANEL CHANNELS

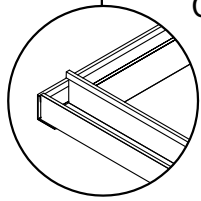

CONNECT DOOR MULLION SECTIONS WITH 20mm SCREWS, REPLACING PADBOLT HASP 10mm SCREWS WITH 20mm SCREWS.

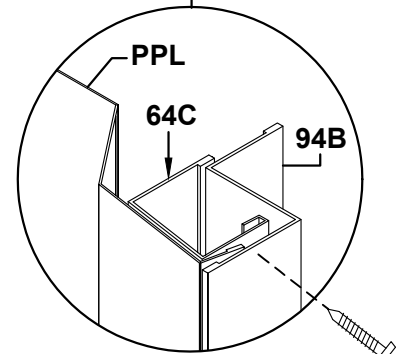

ASSEMBLE LID BRACING

JOIN ALL COMPONENTS AT PRE-PUNCHED LOCATIONS AS SHOWN

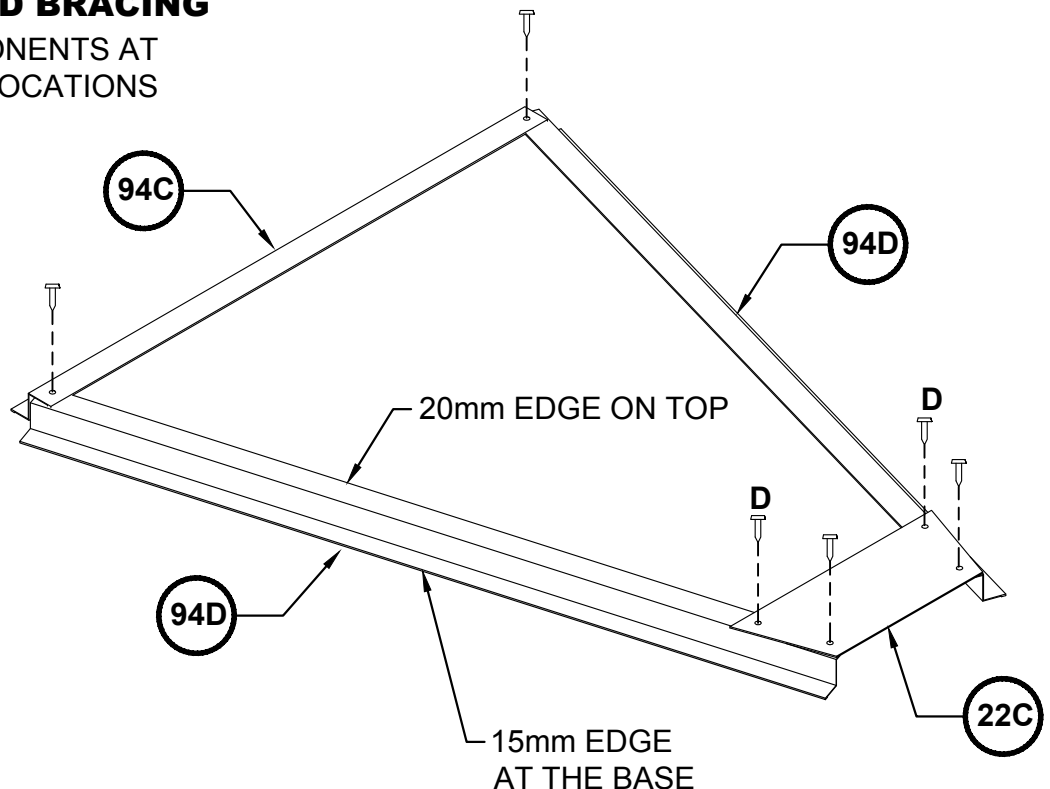

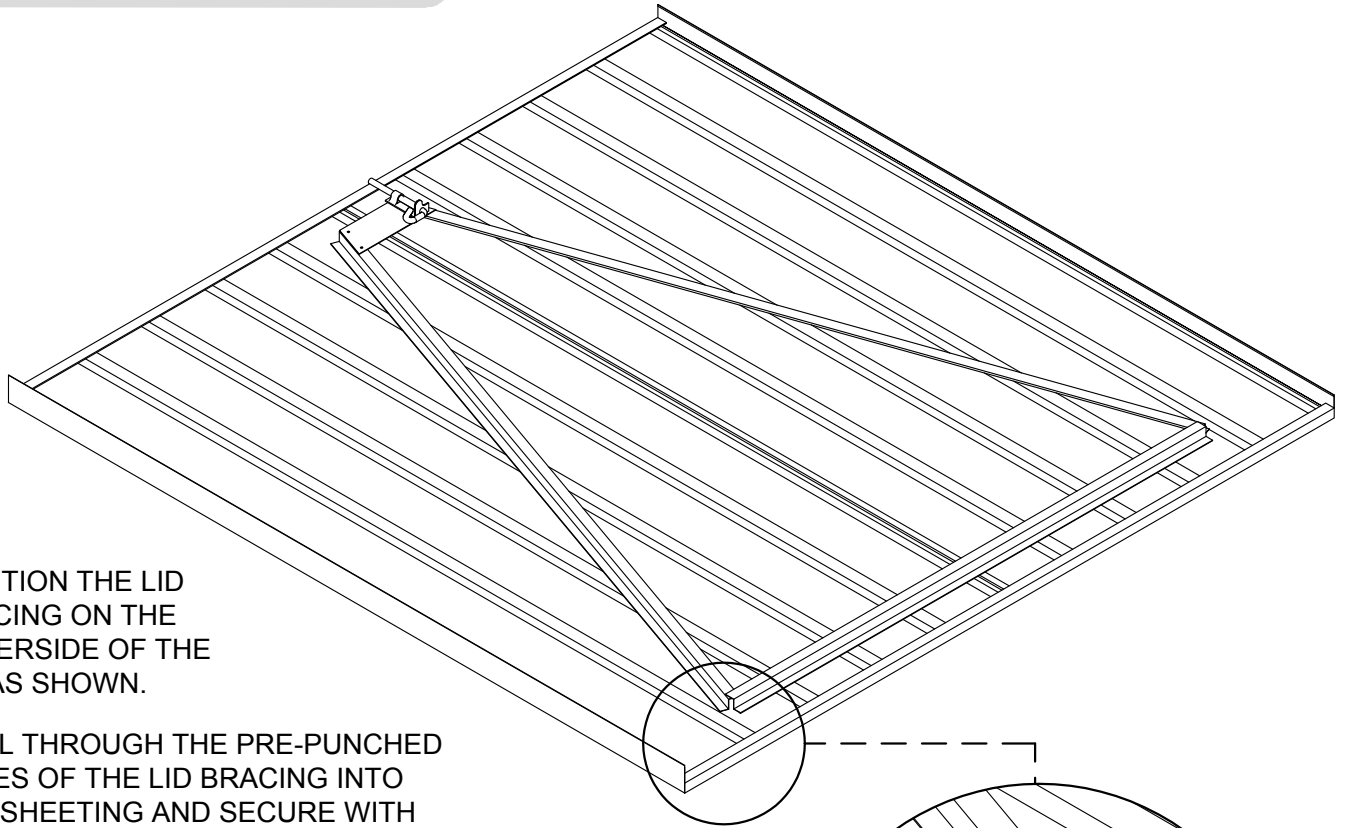

POSITION THE LID BRACING ON THE UNDERSIDE OF THE LID AS SHOWN.

DRILL THROUGH THE PRE-PUNCHED HOLES OF THE LID BRACING INTO THE SHEETING AND SECURE WITH SCREWS.

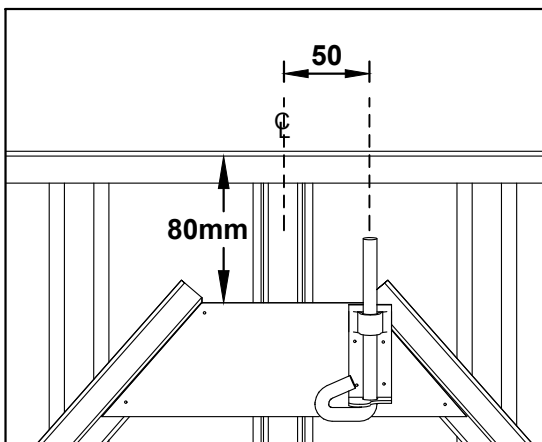
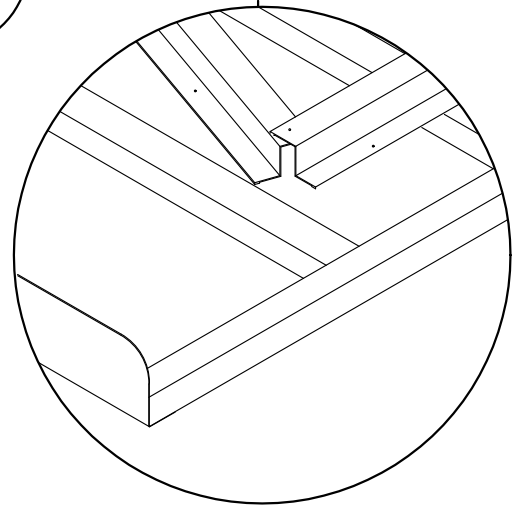

FASTEN PADBOLT PLATE TO BRACES. FASTEN PADBOLT 50mm OFF CENTRE TO ALLOW THE PADBOLT TO LOCK UNDER THE TOP CHANNEL OF THE FRONT PANEL NEXT TO THE DOOR.

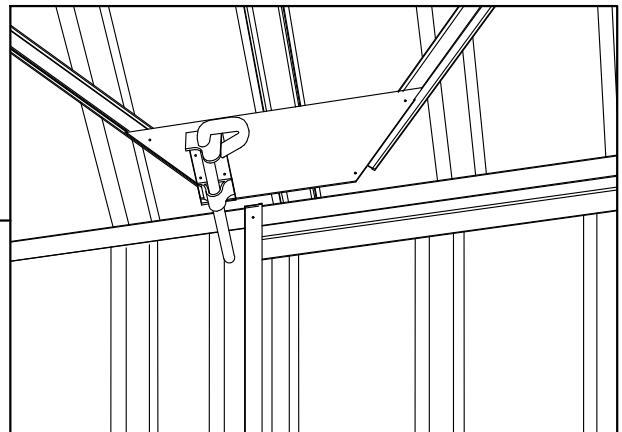

INTERNAL VIEW WITH LID AND DOOR CLOSED

FINAL CONSTRUCTION

DRILL 4.5mm HOLES IN THE TOP CHANNEL AND SECURE HINGES WITH COUNTERSUNK SCREWS AND NUTS

(OPTIONAL)
DRILL HOLES AND SECURE FOUR CORNER BRACES (PART 88D) WITH TWO SCREWS EACH.

ONCE THE UNIT IS SECURED TO A CONCRETE SLAB, YOU MAY FIND THE UNIT IS RIGID ENOUGH WITHOUT THE NEED TO USE THE CORNER BRACES.

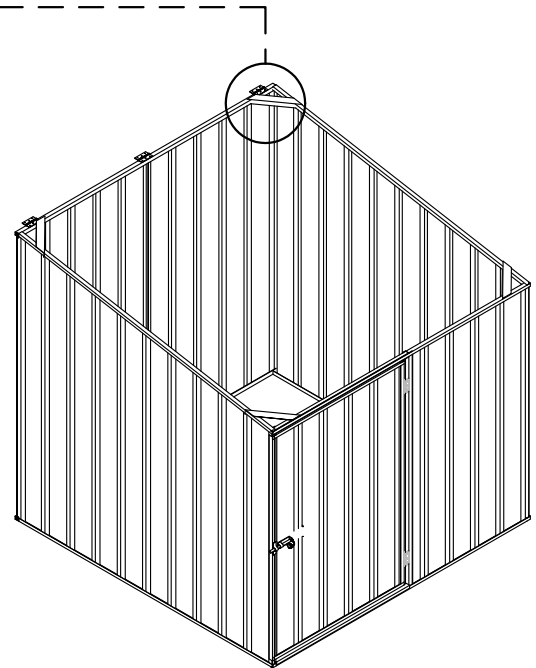
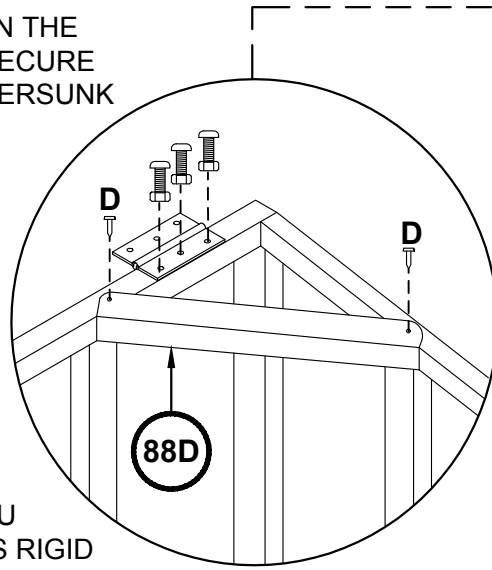

MOVE THE LID INTO POSITION, DRILL 4.5mm HOLES THROUGH THE CHANNEL AND SHEET AND SECURE WITH COUNTERSUNK SCREWS AND NUTS

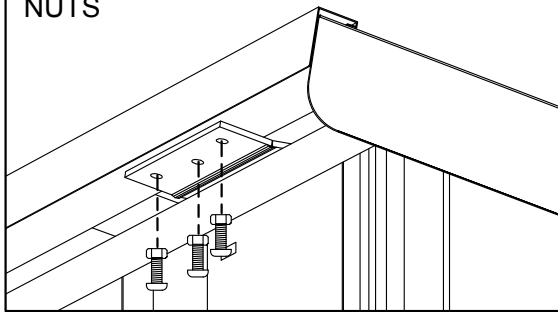

REAR VIEW

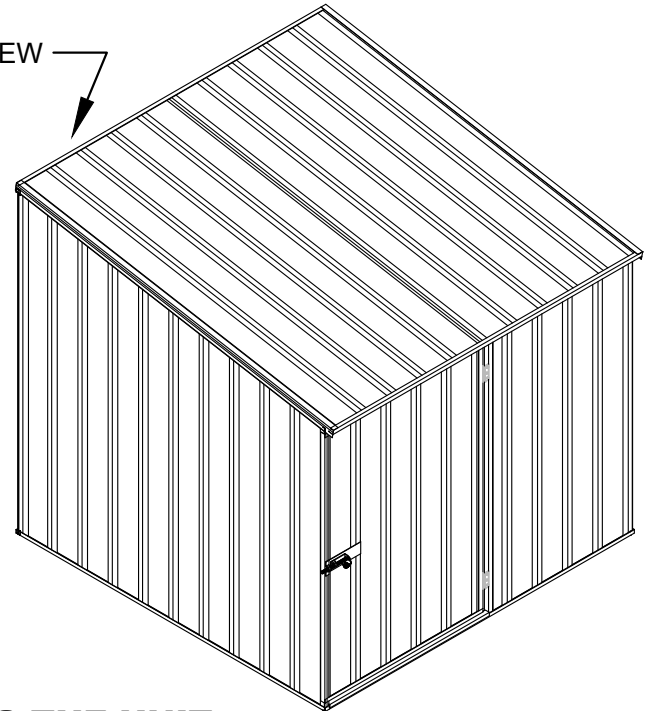

ANCHORING THE UNIT

ANCHORS CONSISTING OF STEEL ANGLE, DYNABOLT, AND NUT AND BOLT ARE AVAILABLE FROM YOUR ABSCO STOCKIST. THIS IS THE RECOMMENDED METHOD OF FIXING THIS UNIT TO A CONCRETE SLAB.

- EACH ANCHOR CONSISTS OF ONE NUT, BOLT, DYNABOLT AND STEEL ANGLE
- DRILL A 10mm HOLE INTO THE WALL SHEET
- DRILL A 10mm HOLE INTO THE CONCRETE

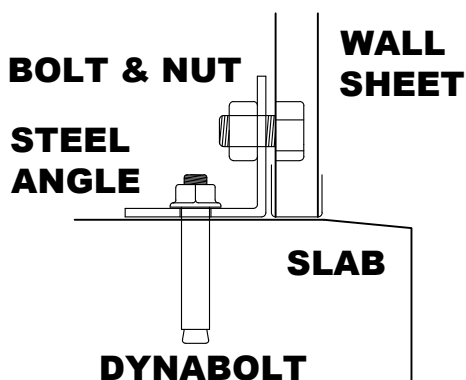

AUSTRALIA PRODUCT WARRANTY AGAINST DEFECTS

Congratulations on your purchase of an ABSCO SHED

ABSCO SHEDS, including garden sheds, garden beds, aviaries, storage units, garages, awnings and carports are made using high quality Australian made steel.

We are pleased to advise we warrant that the steel coating will not rust, crack, flake peel or blister for 30 years from date of purchase, when installed within Australia.

This warranty does not apply to surface deterioration of panels caused by 'Swarf' (Tiny particles of steel debris left from cutting, grinding or drilling operations) that has not been removed after building construction, or as a result of contact with damp soil, chemicals, fertilisers or other corrosive substances.

This warranty covers any Absco product used for normal domestic use and installed in accordance with the installation instructions. The warranty does NOT cover Damage caused by storms, wind, rain snow or poor foundations.

This warranty does NOT cover ABSCO products installed in severe coastal, industrial or other highly corrosive environments. The warranty does not cover fasteners (screws, nuts, bolts, rivets, hasps or sliding padbolts).

The warranty is limited to replacement and delivery of components and does not include any labour or installation costs. The benefits given by the warranty are in addition to your other rights and remedies under a law in relation to the goods or services to which the warranty relates.

The warranty applies to the exclusion of all other representations, guarantees or warranties express or implied, our goods come with guarantees that cannot be excluded under the Australian consumer law and is not transferable. You are entitled to a replacement or refund for a major failure and for compensation for any other foreseeable loss or damage. You are also entitled to have the goods repaired or replaced if the goods fail to be of an acceptable quality and the failure does not amount to a major failure. For further information go to <http://www.consumerlaw.gov.au>.

Please retain a proof of purchase (sales docket or invoice) or register your warranty within 30 days of purchase here: www.absco.com.au/register_warranty.php

In the unlikely event a warranty claim is made, it must be supported by photographic evidence and details of the defect, including component part numbers, together with proof of purchase documentation (or on-line registration of purchase) and forwarded to the address below. Upon receipt of the warranty claim, the Customer Service Manager will contact you within three business days to advise you of the assessment outcome of the claim, which may include your expenses incurred in making the claim.

THE CUSTOMER SERVICE MANAGER, ABSCO INDUSTRIES, PO BOX 119 ACACIA RIDGE QLD AUSTRALIA 4110

PHONE: 1800 029701 FAX: 07-33441191 EMAIL: warranty@absco.com.au

Issued 01 January 2013

ABSCO SHEDS - STORAGE GUIDELINES

ABSCO SHEDS include garden sheds, garden beds, storage units, aviaries, garages, awnings and carports.

ABSCO SHEDS are designed to be weatherproof for normal weather conditions. In the event of extreme weather conditions such as heavy rain, combined with high wind gusts, the ridge capping, sheeting joints, screw fixings etc., may exhibit minor deformations which may allow some water entry. These areas should be checked regularly to ensure that maximum strength and protection is maintained.

Other weather conditions such as extreme heat and extreme cold, moist or dry air can influence the effects of concrete floor moisture and/or condensation on the underside of the roof sheets.

ABSCO SHEDS and storage units are primarily used for storage of garden equipment such as lawnmowers, wheelbarrows, garden tools etc. Storage items that might be adversely affected by any of the above conditions may require additional protection such as being sealed or covered by plastic sheets and/or stacked above the concrete floor on timber slats.

Waterproof sealants may be used to offer further protection where required around joins and screw fixings, as can rubber door seals and other products which are available from most hardware outlets.

Placement of waterproof sealants (silicone) between the base of the shed and concrete slab is not recommended, as this process can have a reverse effect, preventing excess water from escaping, resulting with water accumulating and being trapped inside the shed.

Absco accepts no responsibility for water entry, floor moisture, condensation or the condition of the Contents inside your Absco steel building arising from any of the pre-mentioned weather conditions.