

FRONT BASE
LENGTH: 3.0m

SIDE BASE
LENGTH: 0.78m

FRONT WALL
HEIGHT: 1.8m

REAR WALL
HEIGHT: 1.95m



Quality
ISO 9001



We thank you for choosing an Australian Made Shed.

At GARDENPRO we want to hear what you think about our products and instructions. We love feedback!. Please contact us at feedback@gardenpro.com.au.



TOOLS REQUIRED



OPTIONAL



OPTIONAL

GENERAL INSTRUCTIONS

- Before commencing any assembly, read through these instructions in detail to gain a thorough understanding of assembly methods and associated details.
- Unpack the carton and carefully identify and check off all the parts against the parts described and illustrated on pages three and four.

SITE PREPARATION

- The site for the shed must be level.
- It is recommended that the shed be set on a 100mm concrete slab and anchored down appropriately (refer FINAL CONSTRUCTION page for details).
- Anchor sets are not supplied as standard items with this product.

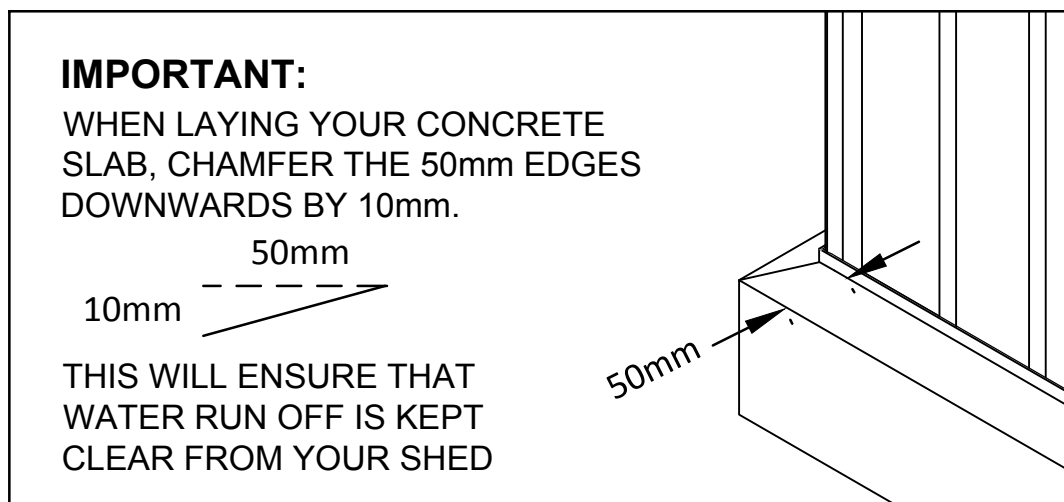

A NOTE ON SAFETY







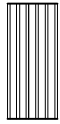
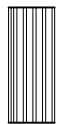
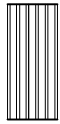
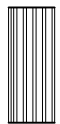
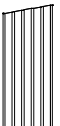
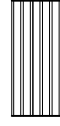
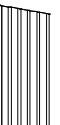
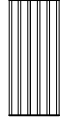

- Some parts may have sharp edges. It is advisable to wear gloves when handling these items and safety glasses if drilling holes. Sensible shoes are highly recommended.
- Do not erect your shed in windy conditions, ensure that the shed is securely anchored to a solid foundation immediately after construction is completed.
- It is highly recommended to erect the shed with two or more people.

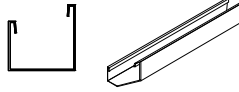
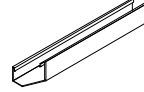
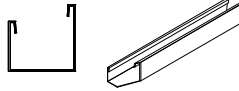
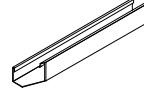
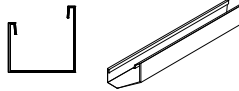
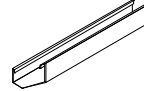
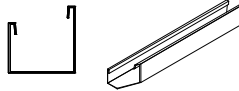
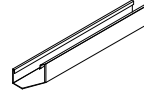
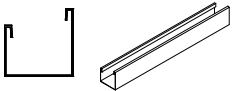
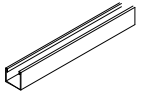

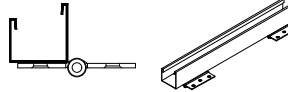

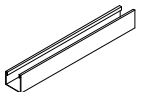
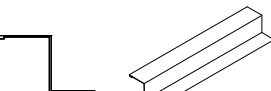
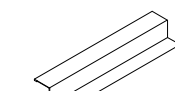
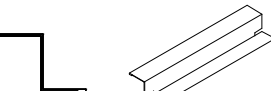
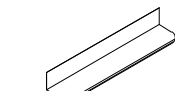

COMPONENTS PACKING LIST - (CONT.) CHECK OFF ALL COMPONENTS

PACKED IN TWO LARGE CARTONS

QTY	COMPONENT DESCRIPTION	PART No.	CHECK	QTY	COMPONENT DESCRIPTION	PART No.	CHECK
2	 STEEL SHEET 1915 X 773mm	43B		4	 STEEL SHEET 865mm X 773mm	43D	
2	 STEEL SHEET 1915 X 773mm	43C		2	 STEEL SHEET 1785mm X 711mm	34A	
1	 STEEL SHEET 1915mm X 773mm	X4L		1	 STEEL SHEET 1725mm X 773mm	A	
1	 STEEL SHEET 1915mm X 773mm	X4R		1	 STEEL SHEET 1725mm X 773mm	B	
1	J30082MCP CHANNEL SET (SEE PAGE 4)			1	INSTRUCTIONS & FITTINGS PACKET (SEE PAGE 5)		

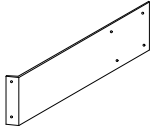
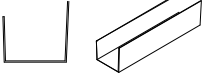
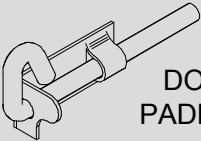
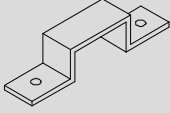
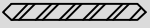
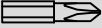
QTY	COMPONENT DESCRIPTION	PART No.	CHECK	QTY	COMPONENT DESCRIPTION	PART No.	CHECK
1	 CHANNEL L = 1496.5mm (58.9")	55AL		1	 CHANNEL L = 1496.5mm (58.9")	55AR	
1	 CHANNEL L = 1496.5mm (58.9")	55CL		1	 CHANNEL L = 1496.5mm (58.9")	55CR	
1	 CHANNEL L = 1496.5mm (58.9")	55BL		1	 CHANNEL L = 1496.5mm (58.9")	55BR	
1	 CHANNEL L = 1496.5mm (58.9")	81BL		1	 CHANNEL L = 1496.5mm (58.9")	81BR	
2	 CHANNEL L = 1496.5mm (58.9")	81AL		2	 CHANNEL L = 1496.5mm (58.9")	81AR	
2	 CHANNEL L = 786mm	61B		2	 CHANNEL WITH HINGES L = 1725mm	58A	
2	 CHANNEL L = 773mm	81J		1	 CHANNEL L = 1725mm	58B	
1	 CHANNEL L = 1568mm	79A		4	 CHANNEL L = 773mm	58C	
2	 JAMB L= 1785mm	89A		4	 JAMB L= 1120mm	91A	
1	 JAMB L= 1725mm	89C		2	 LIP TRIM L= 865mm	88B	
1	 JAMB L= 1568mm	90A					

INSTRUCTIONS & FITTINGS PACKET

QTY	COMPONENT DESCRIPTION	PART No.	CHECK	QTY	COMPONENT DESCRIPTION	PART No.	CHECK
1	ASSEMBLY INSTRUCTIONS			1	DOUBLE DOOR FITTINGS PACK	PSTKDBL	
2	 DOOR STRAP L: 165mm	12A		6	 CHANNEL JOINER L= 200mm (7.9")	CSJ	
PSTKDBL - DOUBLE DOOR FITTINGS PACK							
3	 DOOR PADBOLT	FAST006		2	DOOR PADBOLT HASP 	FAST007	
1	3mm DRILL BIT 	DRILL		1	PHILLIPS DRIVER BIT 	FAST038	
1	 SELF TAPPING SCREWS PACKET CONTAINING 220			1	PACK12P SCREW PACK 12		
PACK12P - SCREW PACK 12							
8	 3/16 ROUND HEAD BOLTS & NYLOCK NUTS			12	 3.2 x 8mm BLIND POP RIVETS		
12	 3/16 COUNTERSUNK SCREWS & NUTS						

INSTRUCTIONS FOR JOINING SPLICED CHANNELS

NOTE: THE TEXT MARKED ON ALL PARTS MUST BE SHOWN ON THE SAME SIDE AS EACH OTHER.

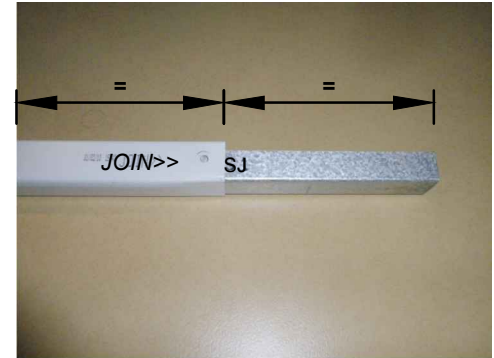
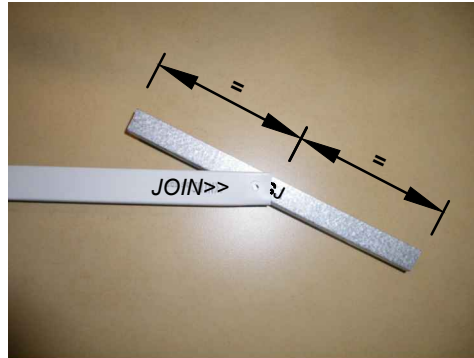
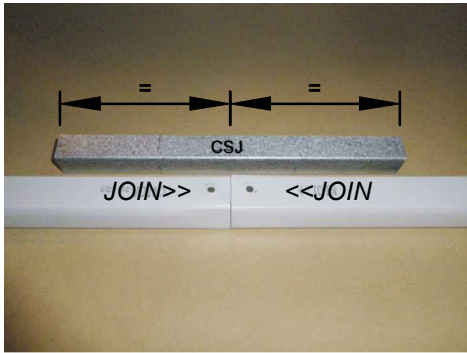

STEP 1.

Position the channels and the CSJ joiner channel so the center of the CSJ is in line with the end of each channel to be joined together.

STEP 2.

Join the first channel to the CSJ by inserting the center of the CSJ (on an angle) to the end of the channel where the JOIN>> text is marked. Push down one side of the CSJ until you hear a 'click'.

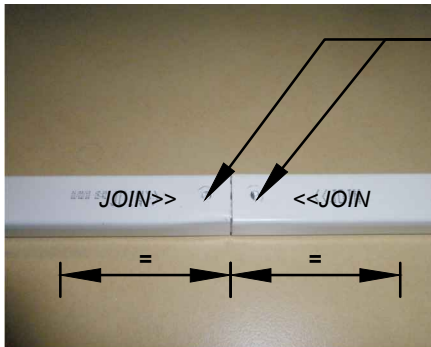
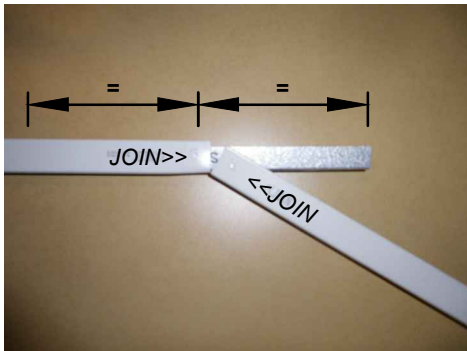

DRILL 4 x 3mm (2 PER A SIDE) HOLES TO SECURE SECTIONS TOGETHER. (THESE SCREWS MAY HAVE TO BE TEMPORARILY REMOVED AND REPLACED DURING LATER ASSEMBLY)

STEP 3.

Join the second channel to the CSJ by positioning the <<JOIN end of the channel at the center of the CSJ (on an angle). Push the CSJ into the channel until you here a 'click'.

FINISHED CHANNEL

The joined channels should now look like the picture above with the CSJ positioned equally inside of the joined channels.

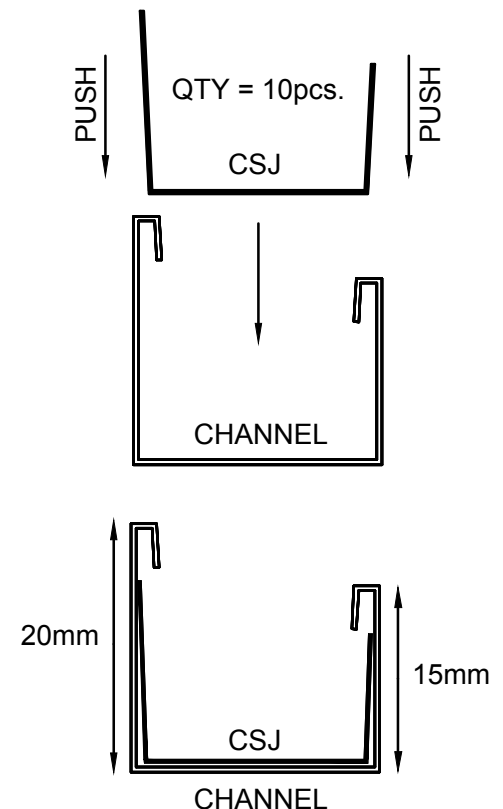
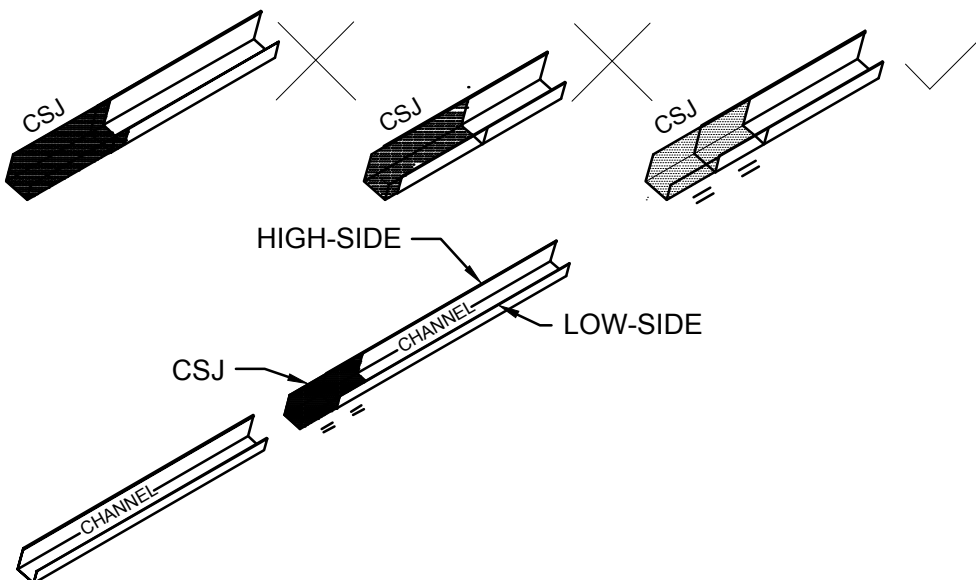

STEP 1. PRE-ASSEMBLY OF SPLICED CHANNELS

NOTE: JOIN TOGETHER 20 X CHANNEL SECTIONS USING 10 X CHANNEL JOINERS (PART CSJ)

NOTE: SOME CHANNELS HAVE HOLES IN THEM - YOU WILL NEED TO RE-DRILL HOLES ON ANY CHANNEL WHERE THE CSJ JOINING CHANNEL COVERS HOLES ON THE CHANNELS YOU ARE CONNECTING

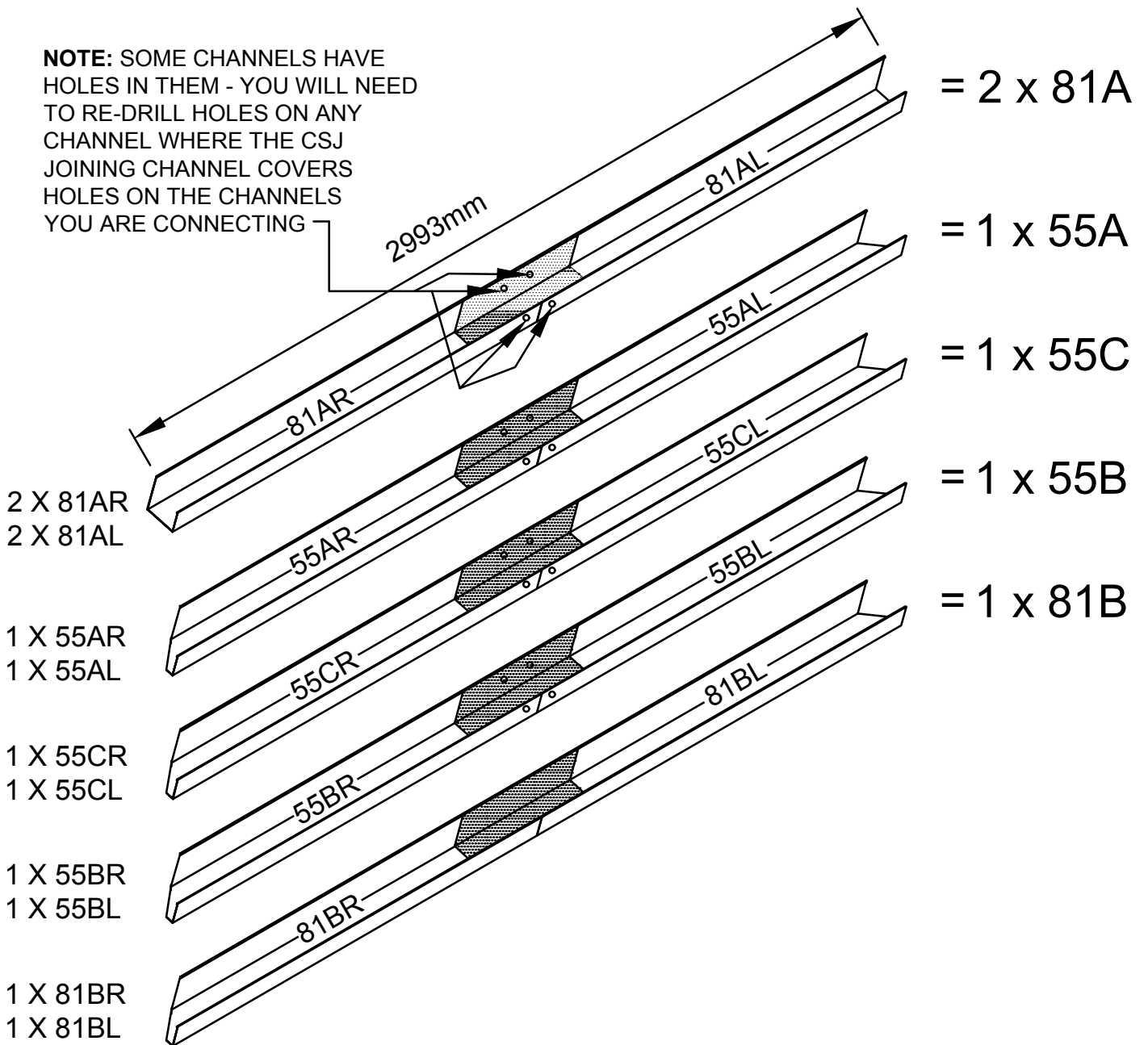

VIEW OF ROOF COMPONENTS

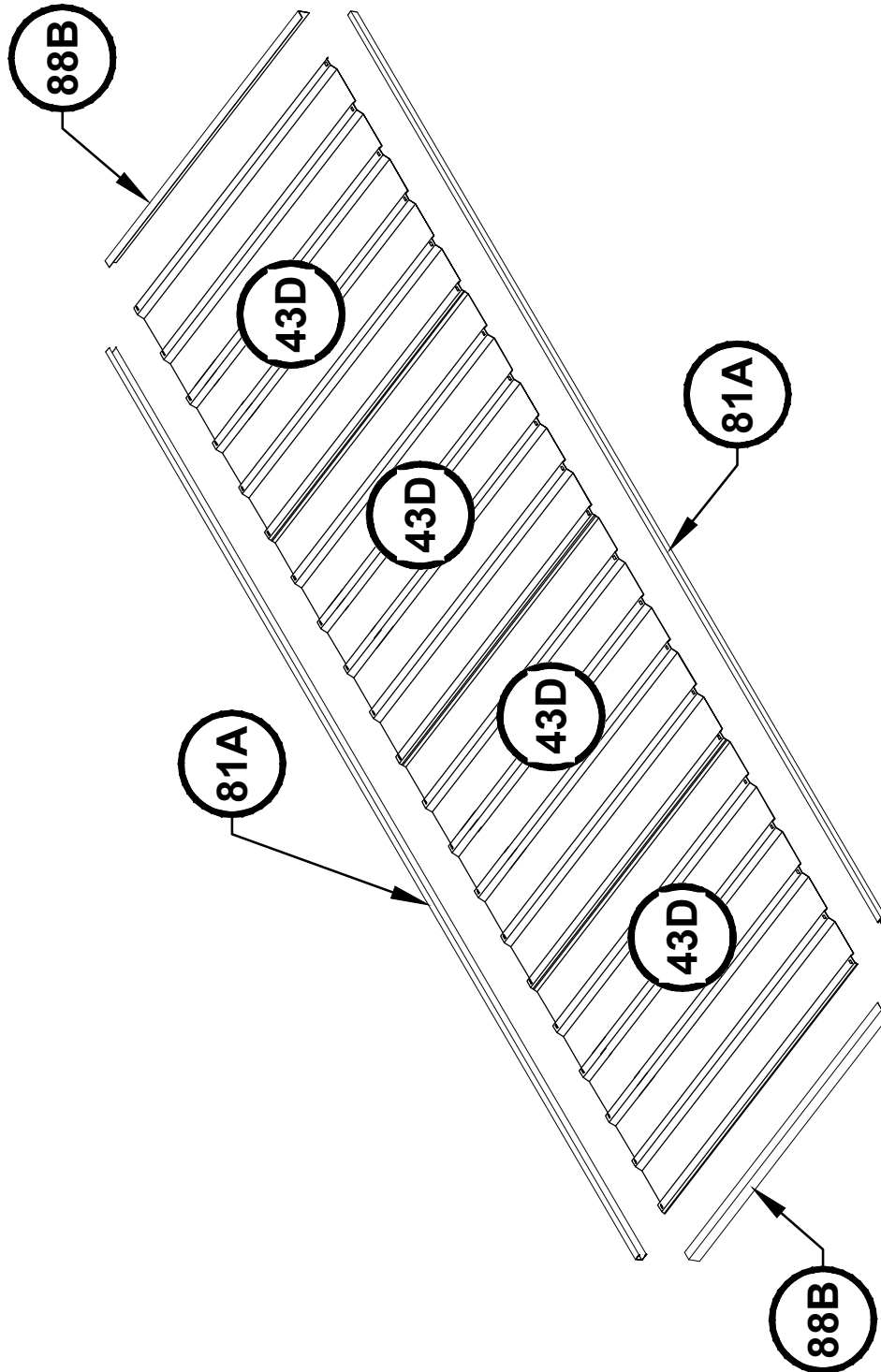



22A

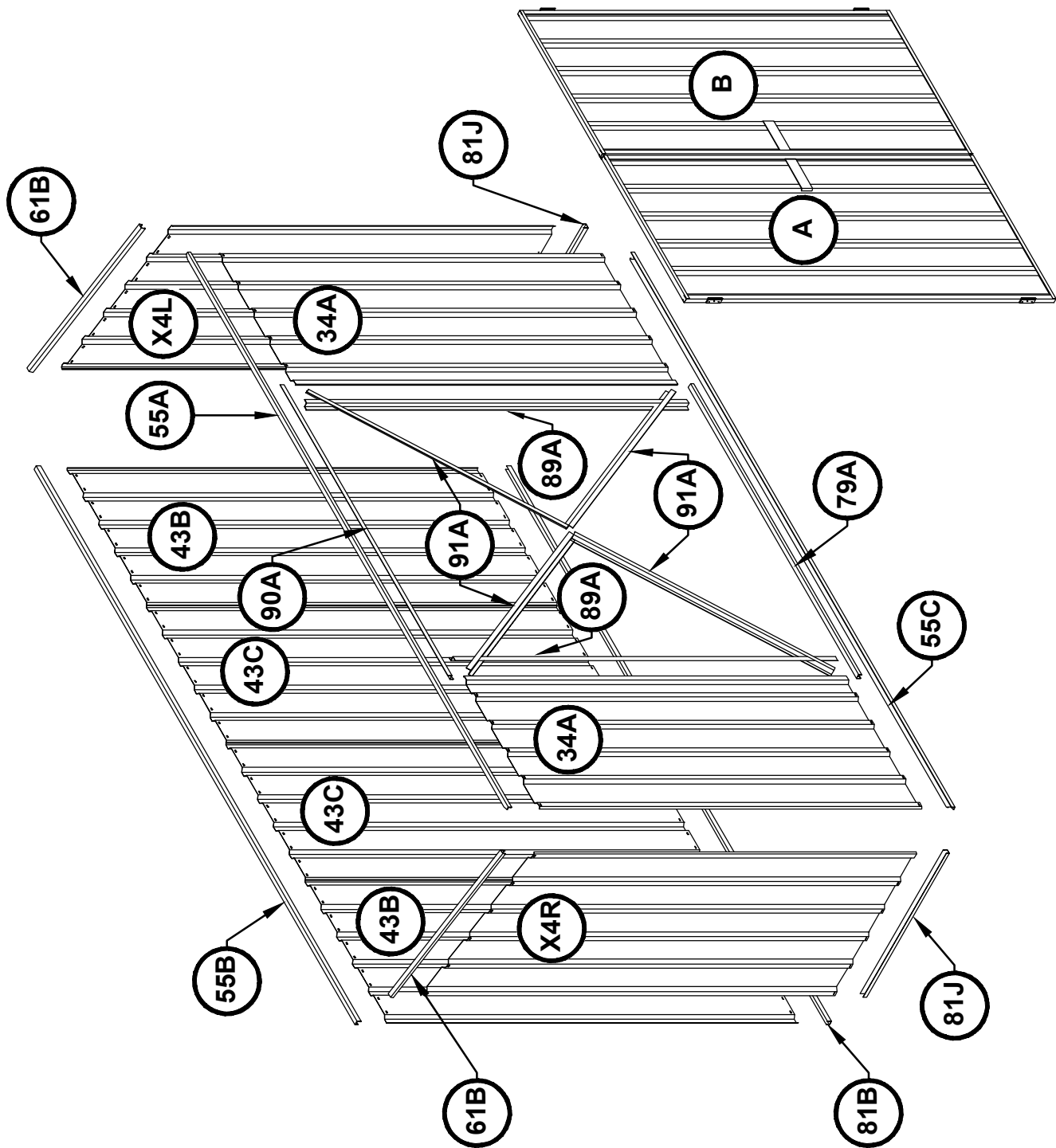

VIEW OF WALL COMPONENTS

ASSEMBLY INTRODUCTION

The snap-tite assembly system locks most perimeter channels to all roof and wall sheets without the need for tools and fasteners.

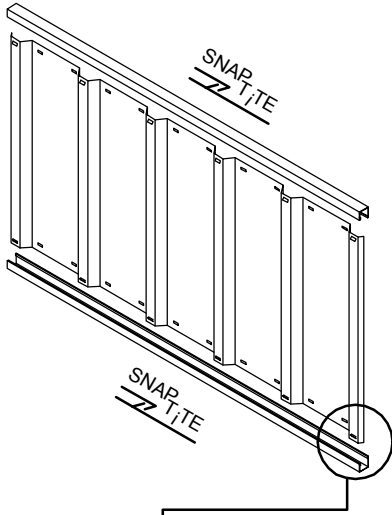

To pre-assemble the four wall panels and two roof panels, the perimeter channels are secured to the top and bottom of each panel using the snap-tite system, as detailed on the following pages wherever you see the symbol.



NOTE: The 'high side' is always on the inside of the shed.

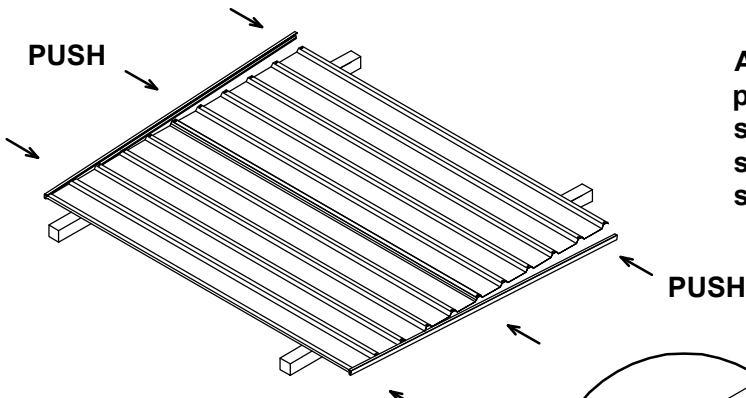
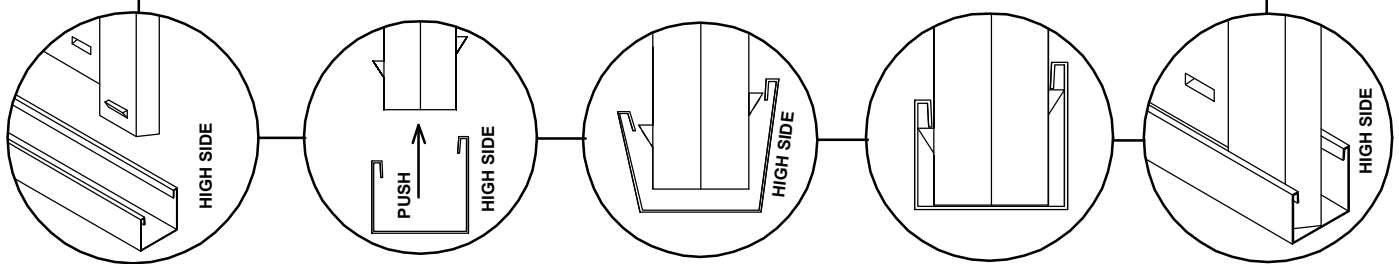
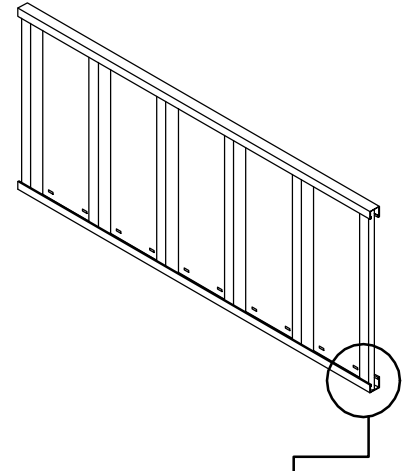

After joining sheets together, position channel over one end of the sheets, gently tapping it over the snap-tite lugs, working along the sheets to the other end.

Position sheets on timbers, trestles or partly over edge of concrete slab.

Each perimeter channel must finish flush with the edges of the sheets. the snap-tite system allows adjustment for this process by simply tapping the channel along the sheets until each end is neatly flush.

FASTENING SYMBOLS

 Join components together with one screw at this location only, as some channel sections have extra holes that are not required for this model of garden shed

 3mm POP RIVETS

 4mm NUT & BOLT SET

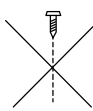
 Do not join components together at this location yet, as the screw may obstruct further assembly of other components

DOOR PANEL ASSEMBLY

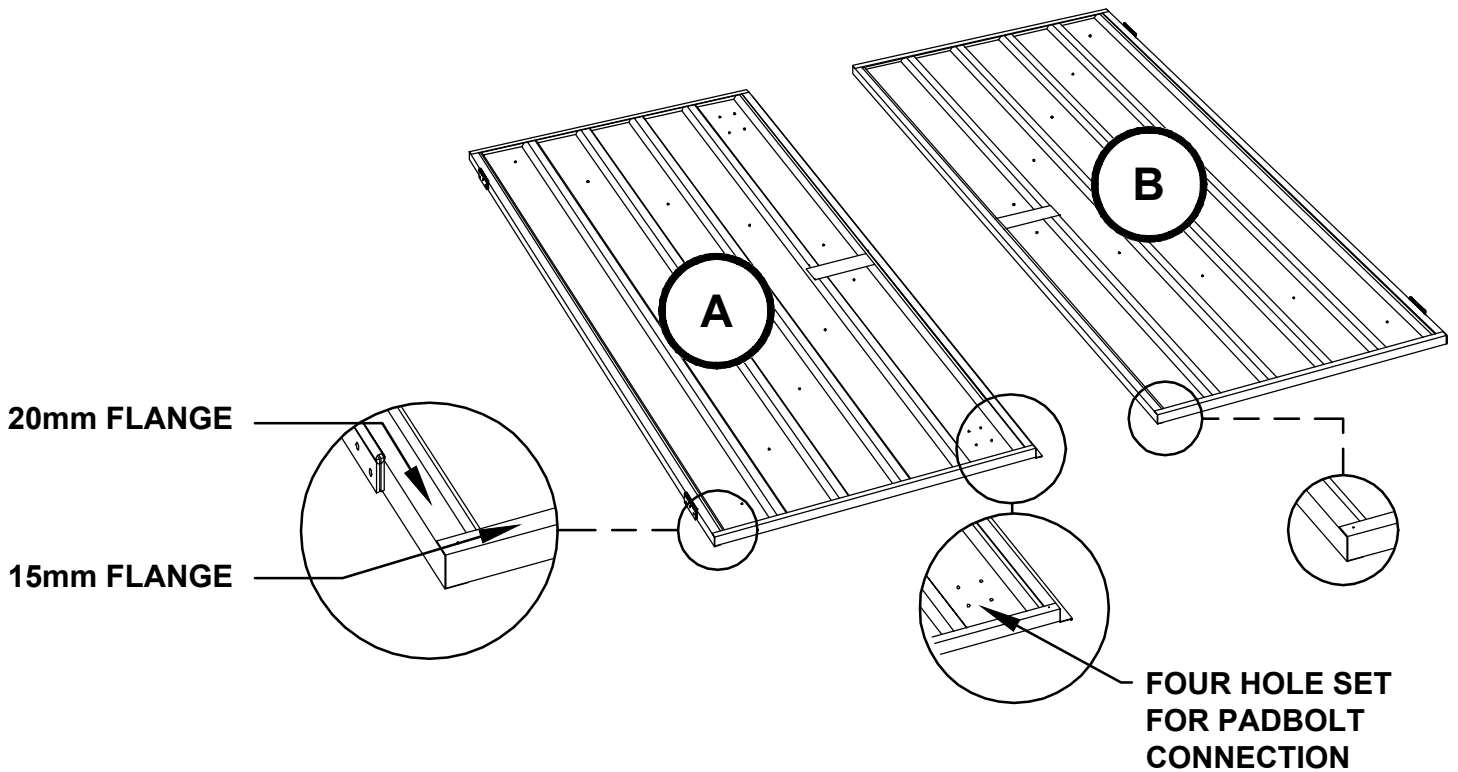
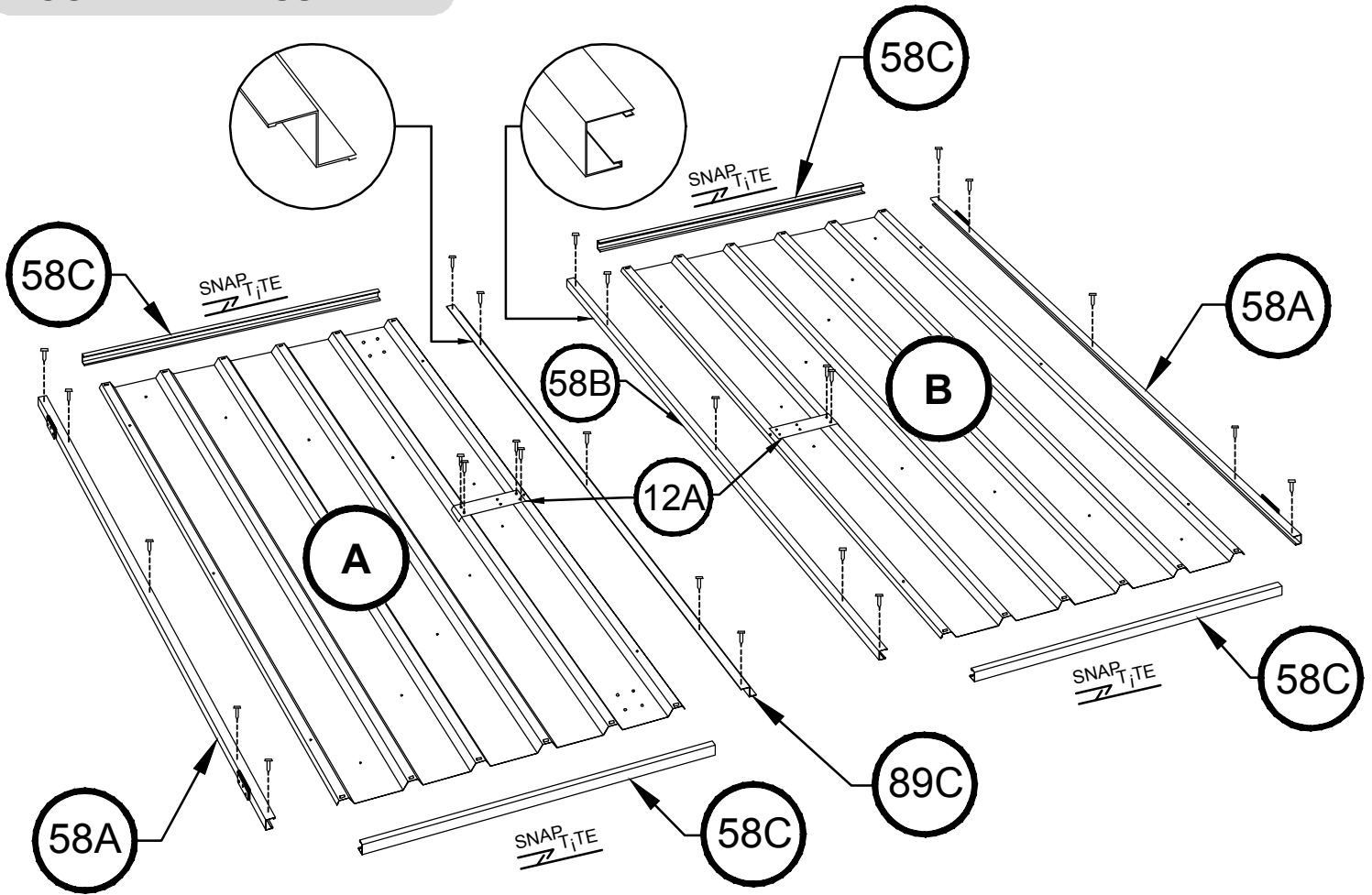

REAR PANEL ASSEMBLY

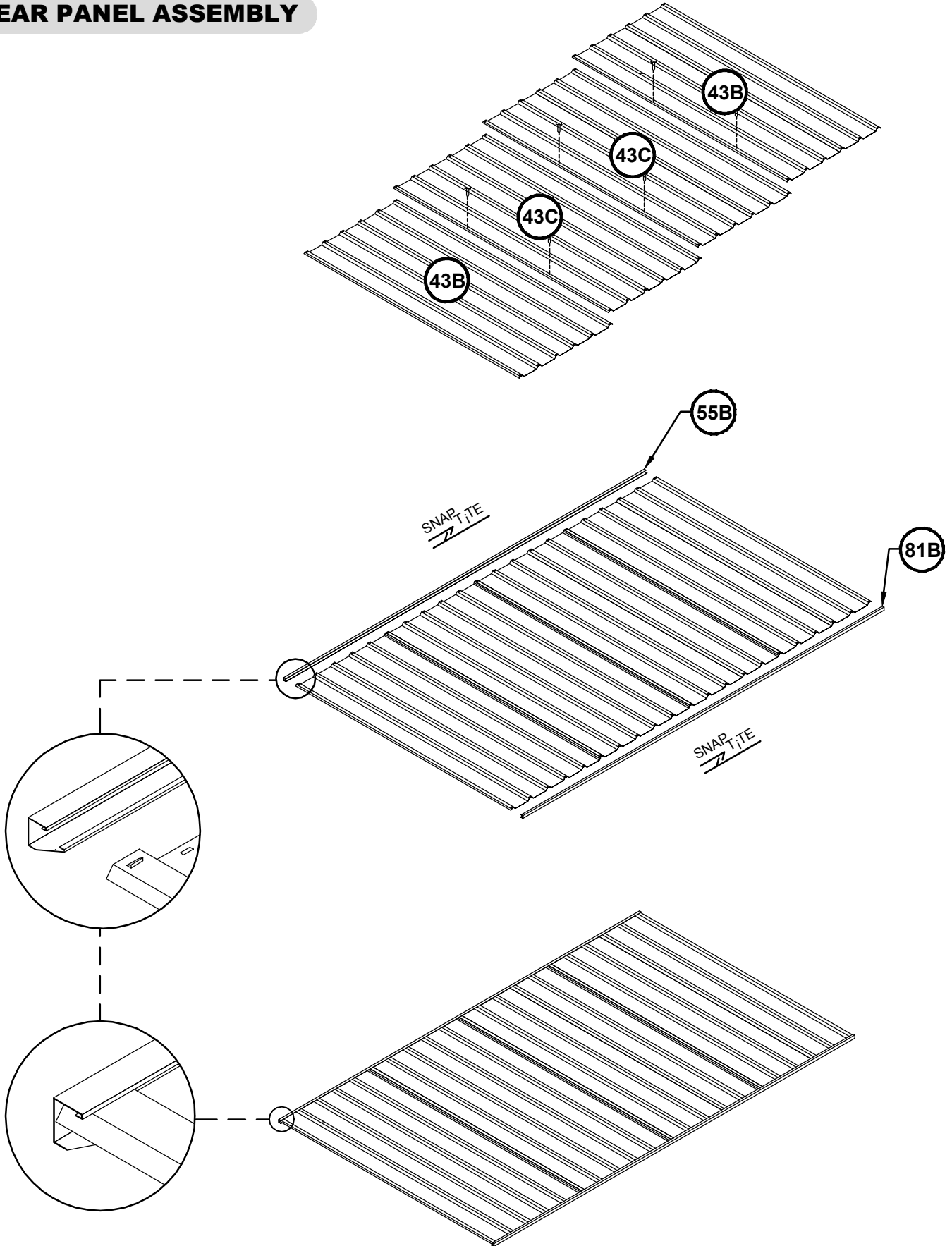

SIDE PANEL ASSEMBLY

(TWO REQUIRED)

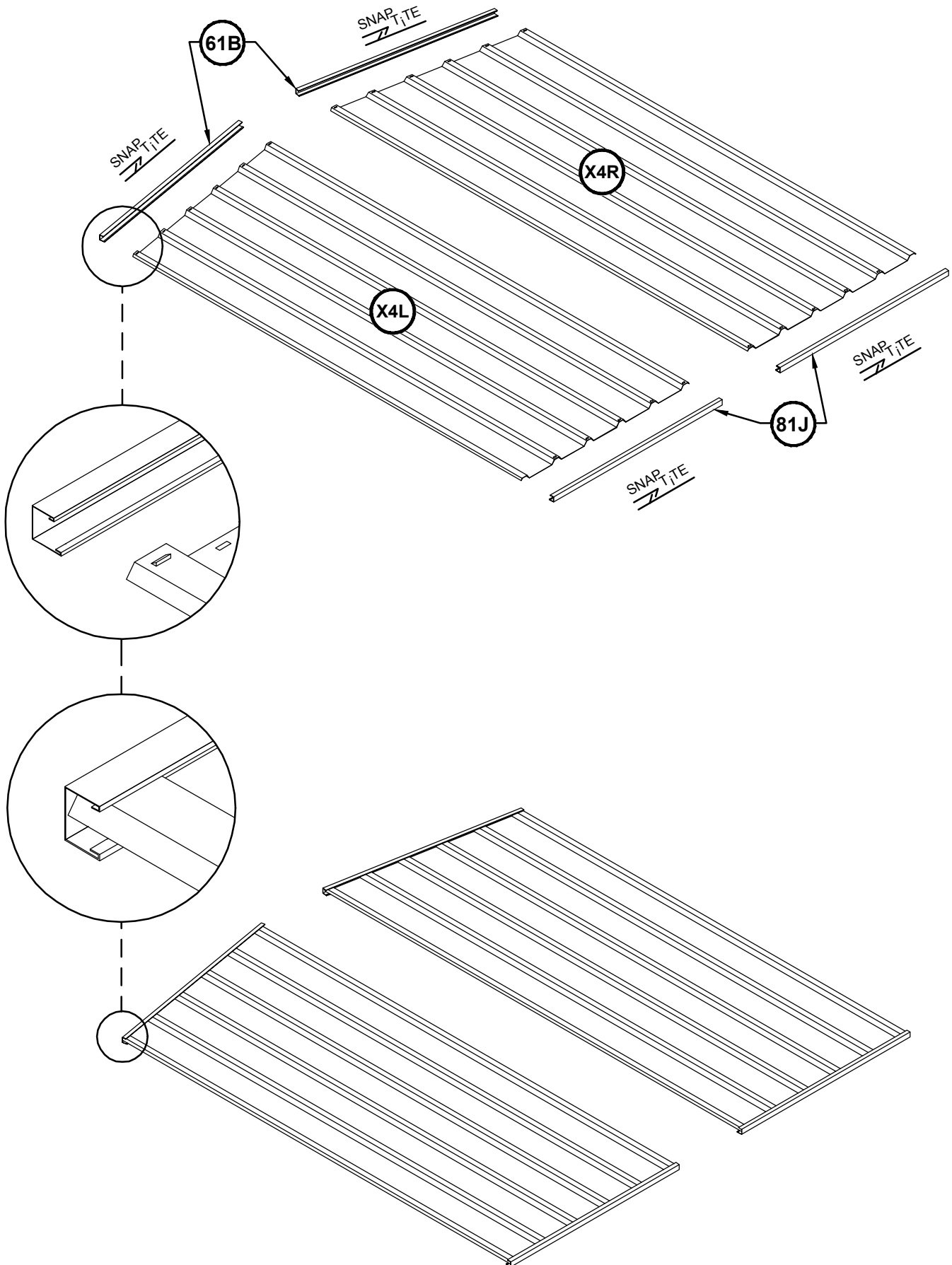

ROOF PANEL ASSEMBLY

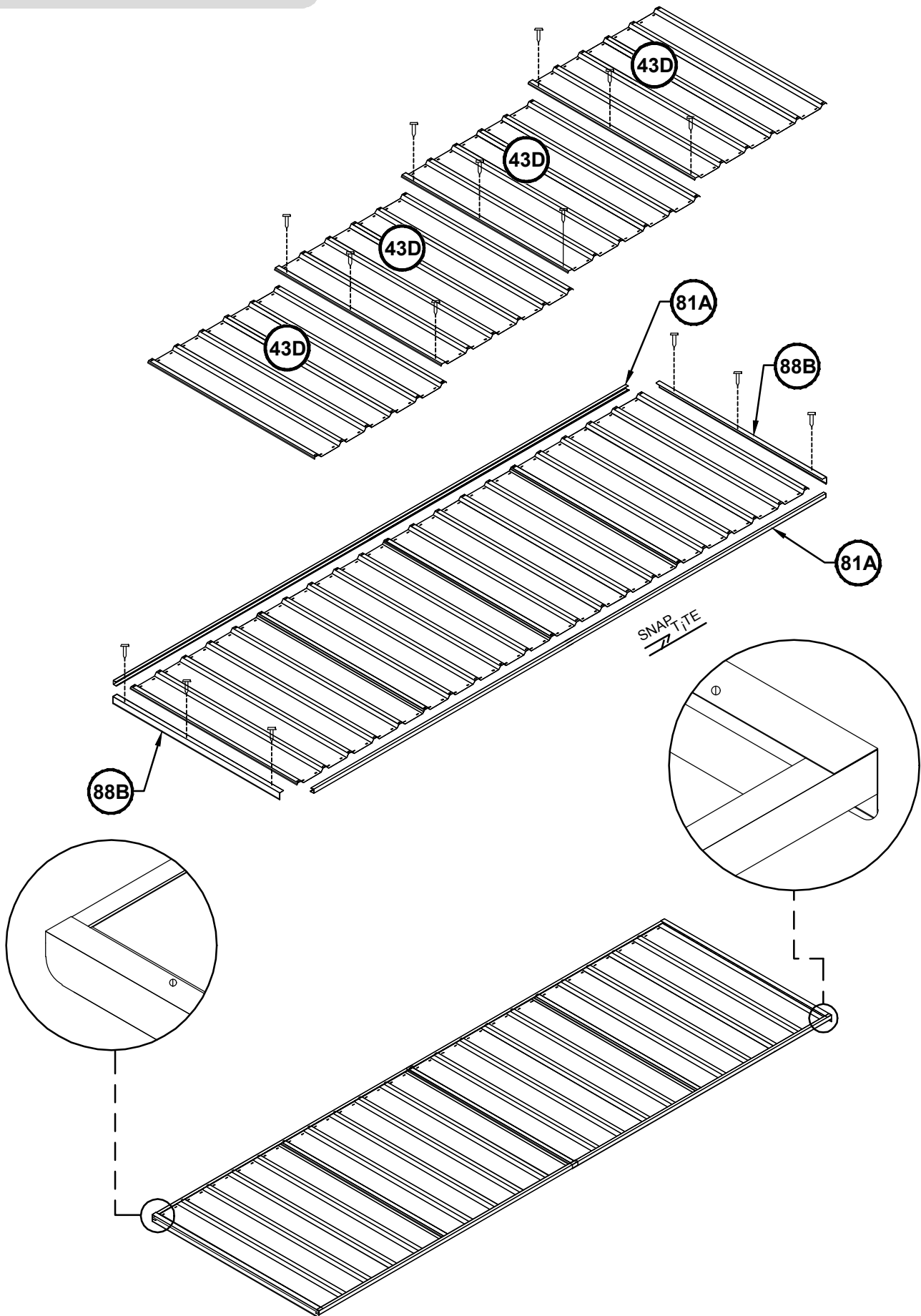

FRONT PANEL ASSEMBLY

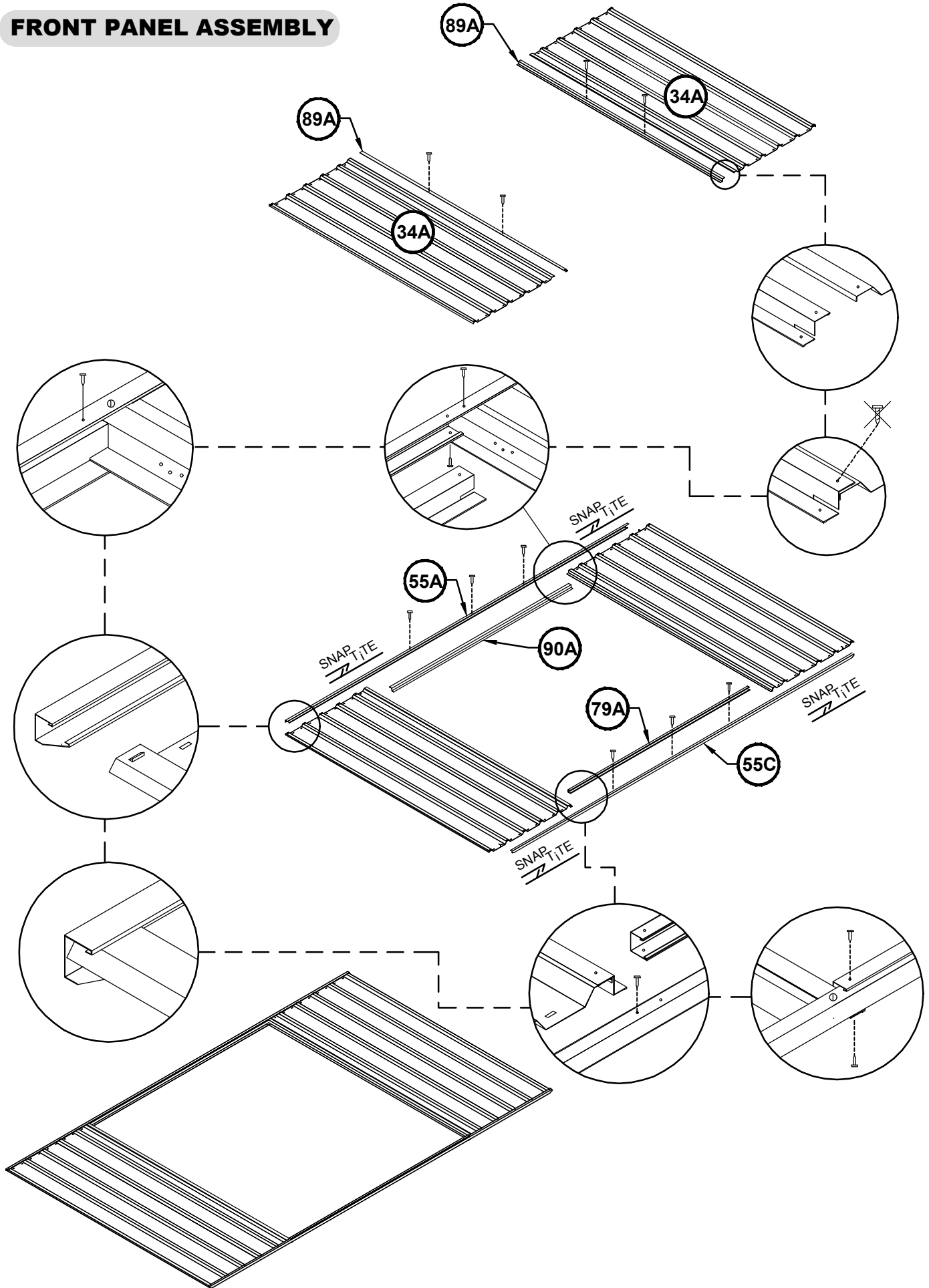

DOOR PANEL ASSEMBLY

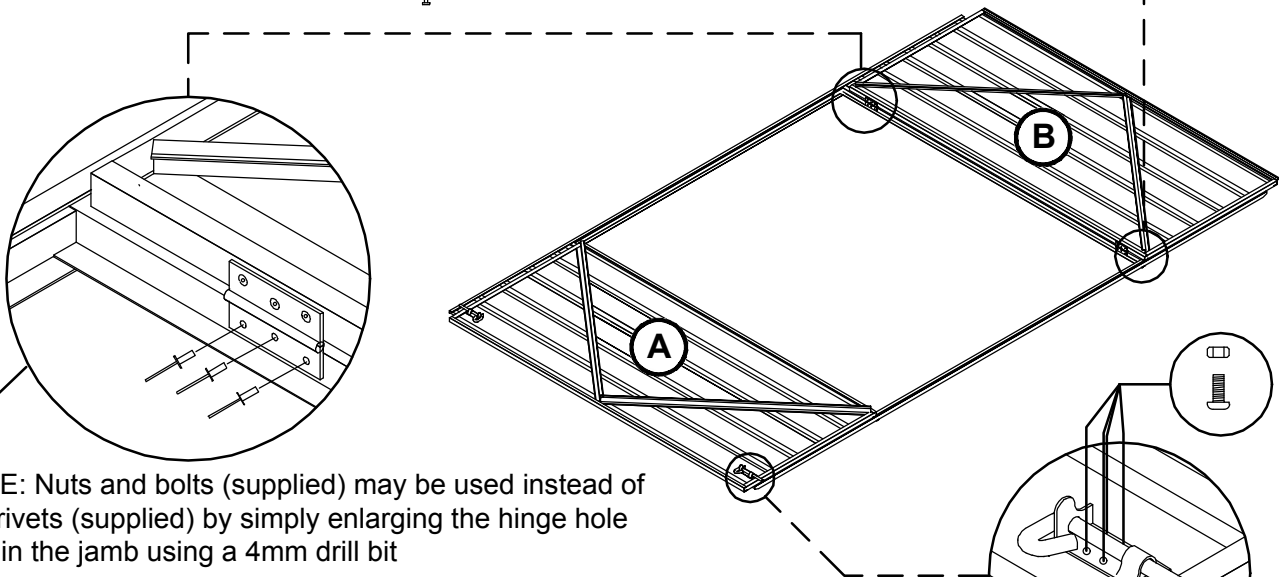
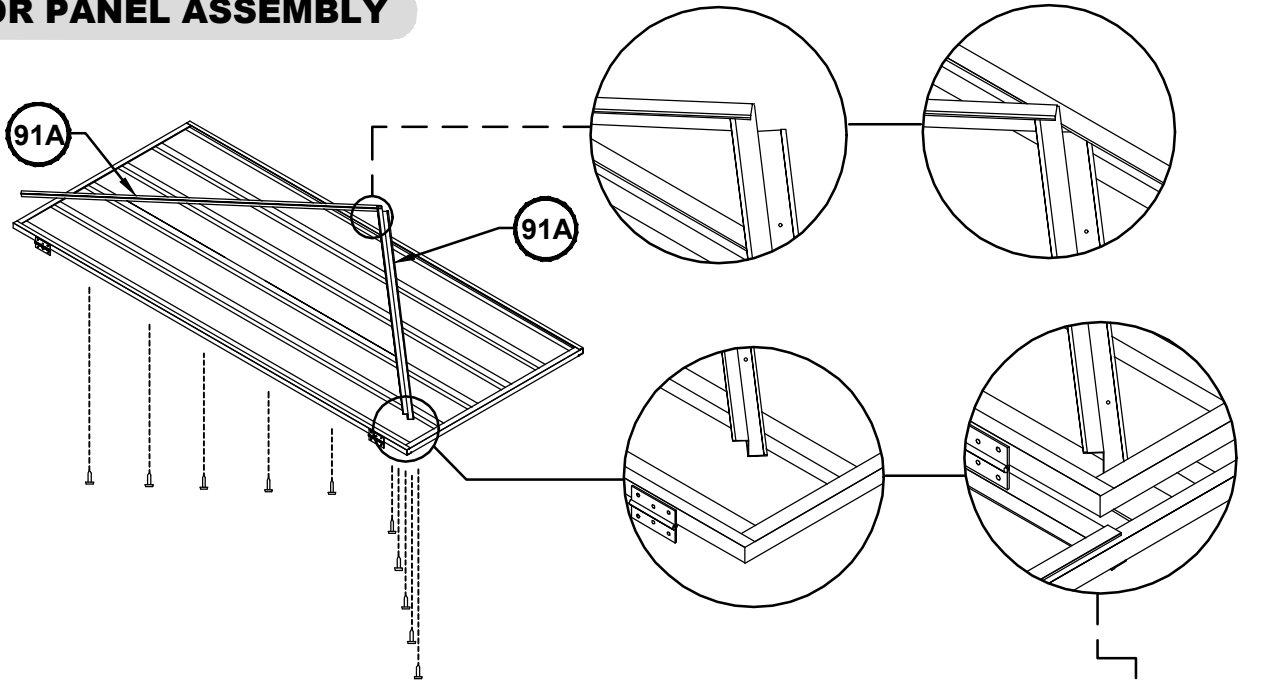

NOTE: Nuts and bolts (supplied) may be used instead of pop rivets (supplied) by simply enlarging the hinge hole sets in the jamb using a 4mm drill bit

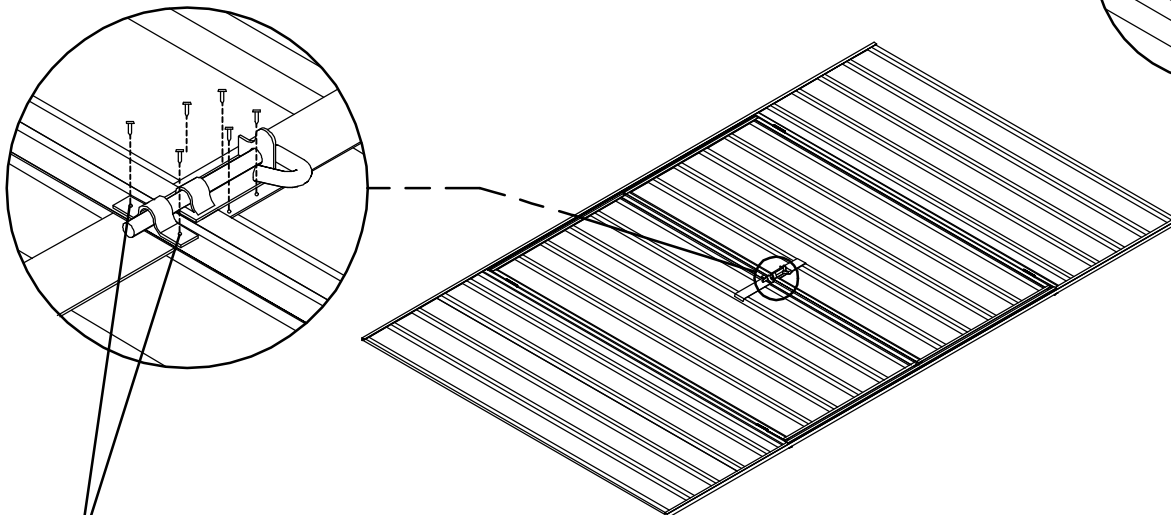

NOTE: The two holes required to connect the padbolt hasp for each door have not been pre-punched, to allow for proper alignment. position each hasp centrally over the padbolt shaft, and drill 3mm holes and secure with screws

PANEL CONSTRUCTION

NOTE: Take care to ensure that both front and rear wall panels are not positioned upside down. The top channel of each panel is pre-punched for attaching roof sheets. The base channels are not pre-punched.

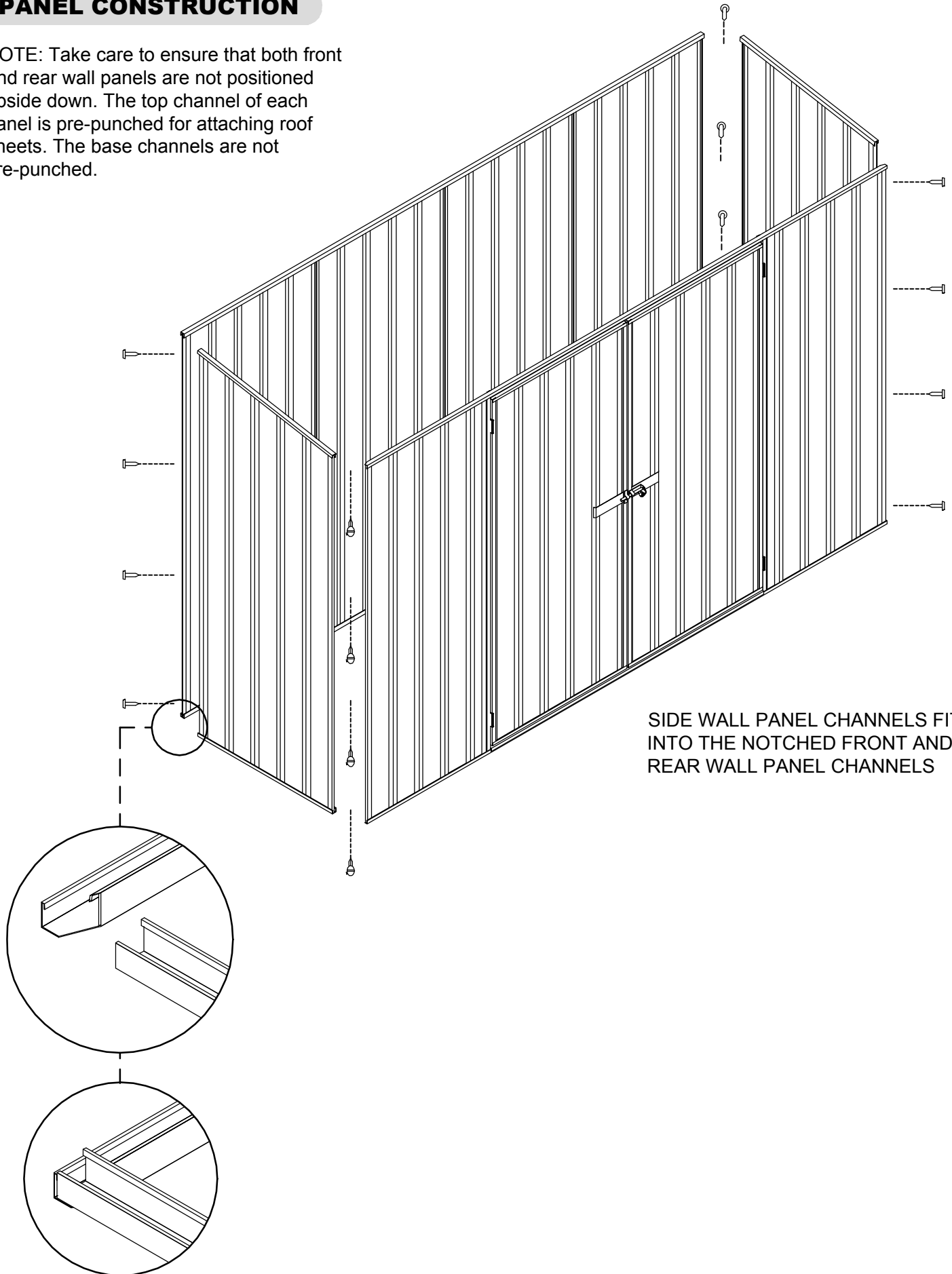

SIDE WALL PANEL CHANNELS FIT INTO THE NOTCHED FRONT AND REAR WALL PANEL CHANNELS

FINAL CONSTRUCTION

ANCHORING OF SHED

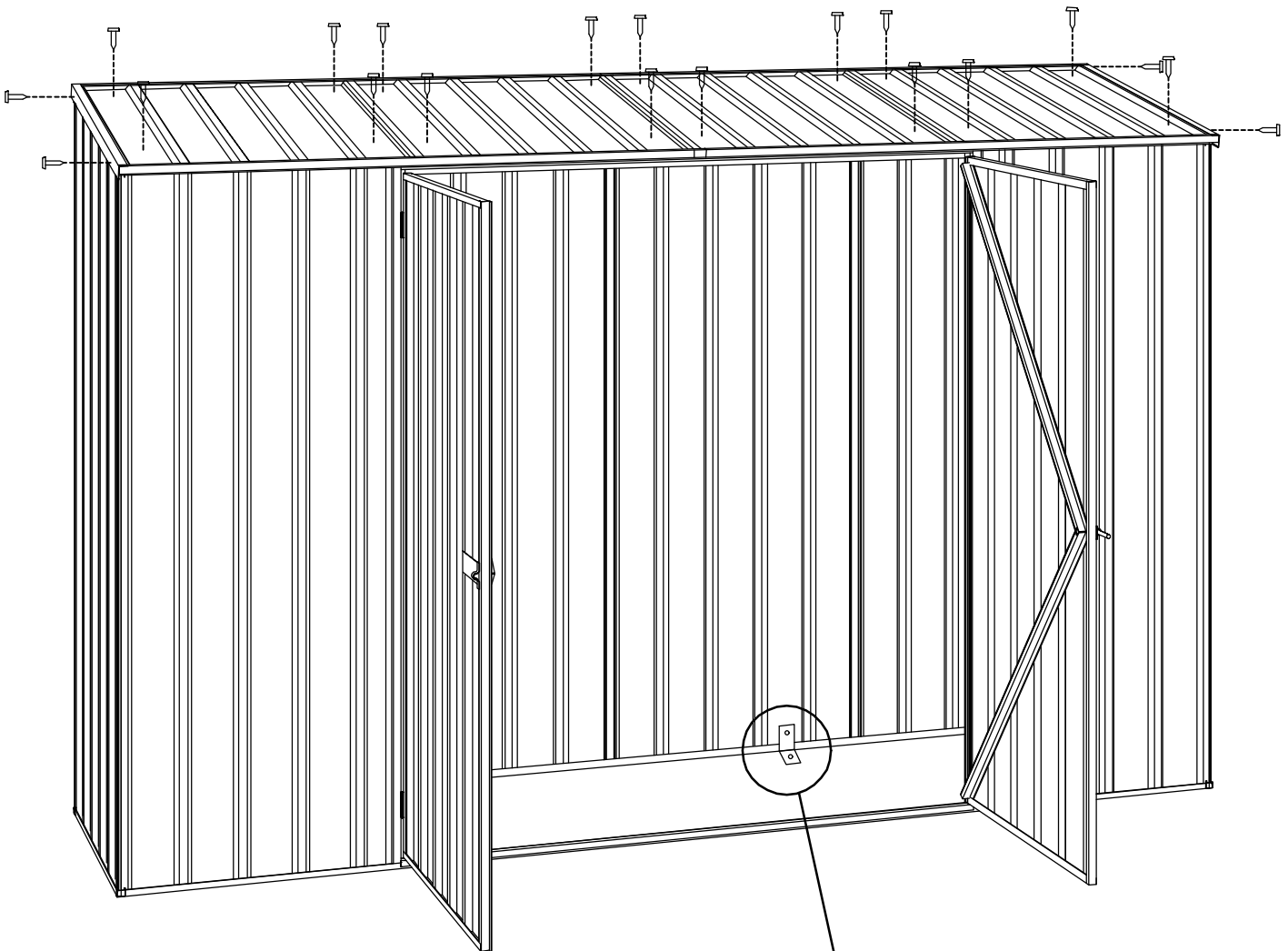
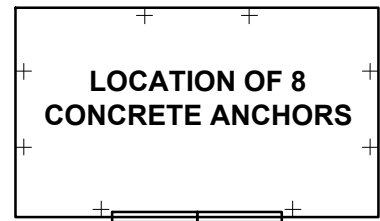

- EACH ANCHOR CONSISTS OF ONE NUT, BOLT, DYNABOLT AND STEEL ANGLE
- DRILL A 10mm HOLE INTO THE WALL SHEET
- DRILL A 10mm HOLE INTO THE CONCRETE

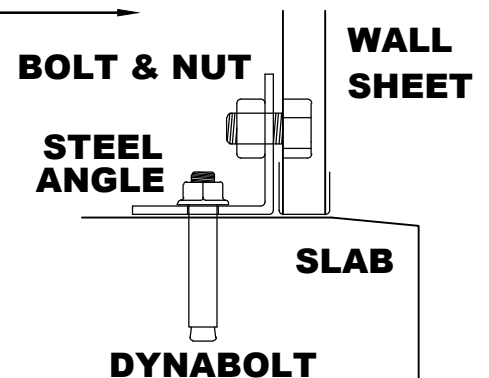

AUSTRALIAN PRODUCT WARRANTY AGAINST DEFECTS

Congratulations on your purchase of an GARDENPRO SHED

GARDENPRO SHEDS, including garden sheds, garden beds, aviaries, storage units, garages, awnings and carports are made using high quality Australian made steel.

We are pleased to advise we warrant that the steel coating will not rust, crack, flake peel or blister for **20 years** from date of purchase, when installed within Australia.

This warranty does not apply to surface deterioration of panels caused by 'Swarf' (Tiny particles of steel debris left from cutting, grinding or drilling operations) that has not been removed after building construction, or as a result of contact with damp soil, chemicals, fertilisers or other corrosive substances.

This warranty covers any GARDENPRO product used for normal domestic use and installed in accordance with the installation instructions. The warranty does NOT cover Damage caused by storms, wind, rain snow or poor foundations.

This warranty does NOT cover GARDENPRO products installed in severe coastal, industrial or other highly corrosive environments. The warranty does not cover fasteners (screws, nuts, bolts, rivets, hasps or bolts).

The warranty is limited to replacement and delivery of components and does not include any labour or installation costs. The benefits given by the warranty are in addition to your other rights and remedies under a law in relation to the goods or services to which the warranty relates.

The warranty applies to the exclusion of all other representations, guarantees or warranties express or implied, our goods come with guarantees that cannot be excluded under the Australian consumer law and is not transferable. You are entitled to a replacement or refund for a major failure and for compensation for any other foreseeable loss or damage. You are also entitled to have the goods repaired or replaced if the goods fail to be of an acceptable quality and the failure does not amount to a major failure. For further information go to <http://www.consumerlaw.gov.au>.

Please retain a proof of purchase (sales docket or invoice) or register your warranty within 30 days of purchase here:
<http://gardenprosheds.com.au/register-warranty/>

In the unlikely event a warranty claim is made, it must be supported by photographic evidence and details of the defect, including component part numbers, together with proof of purchase documentation (or on-line registration of purchase) and forwarded to the address below. Upon receipt of the warranty claim, the Customer Service Manager will contact you within three business days to advise you of the assessment outcome of the claim, which may include your expenses incurred in making the claim.

THE CUSTOMER SERVICE MANAGER, GARDENPRO INDUSTRIES, PO BOX 119 ACACIA RIDGE QLD AUSTRALIA 4110

PHONE: 1800-029-701-----FAX: 07-3344-1191-----EMAIL: warranty@GARDENPRO.com.au

Issued 20 September 2017

GARDENPRO SHEDS - STORAGE GUIDELINES

GARDENPRO SHEDS include garden sheds, garden beds, storage units, aviaries, garages, awnings and carports.

GARDENPRO SHEDS are designed to be weatherproof for normal weather conditions. In the event of extreme weather conditions such as heavy rain, combined with high wind gusts, the ridge capping, sheeting joints, screw fixings etc., may exhibit minor deformations which may allow some water entry. These areas should be checked regularly to ensure that maximum strength and protection is maintained.

Other weather conditions such as extreme heat and extreme cold, moist or dry air can influence the effects of concrete floor moisture and/or condensation on the underside of the roof sheets.

GARDENPRO SHEDS and storage units are primarily used for storage of garden equipment such as lawnmowers, wheelbarrows, garden tools etc. Storage items that might be adversely affected by any of the above conditions may require additional protection such as being sealed or covered by plastic sheets and/or stacked above the concrete floor on timber slats.

Waterproof sealants may be used to offer further protection where required around joins and screw fixings, as can rubber door seals and other products which are available from most hardware outlets.

Placement of waterproof sealants (silicone) between the base of the shed and concrete slab is not recommended, as this process can have a reverse effect, preventing excess water from escaping, resulting with water accumulating and being trapped inside the shed.

GARDENPRO accepts no responsibility for water entry, floor moisture, condensation or the condition of the Contents inside your GARDENPRO steel building arising from any of the pre-mentioned weather conditions.