

# WAGNER

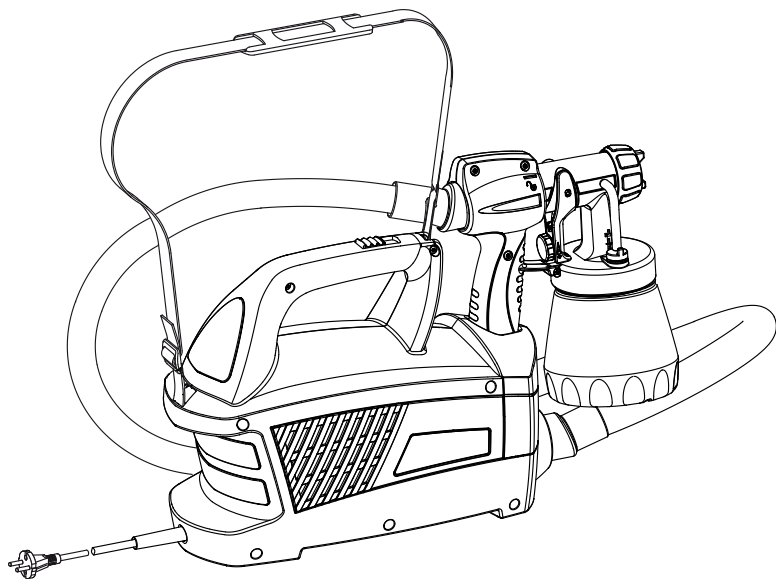

**CLICK  
&  
PAINT**  
TECHNOLOGY



2 Jahre  
Garantie

2 years  
WARRANTY

2 ans de  
GARANTIE

2 ans de  
GARANTIE

**W 670**  
**D/GB/F/NL**



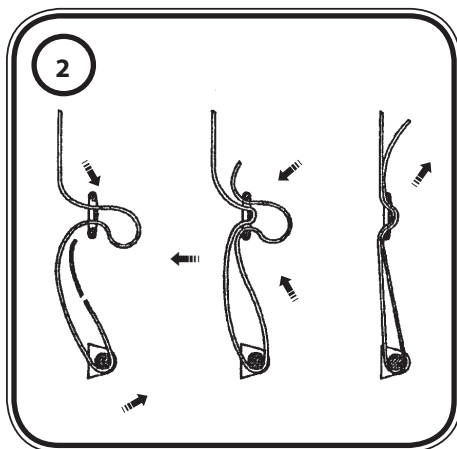
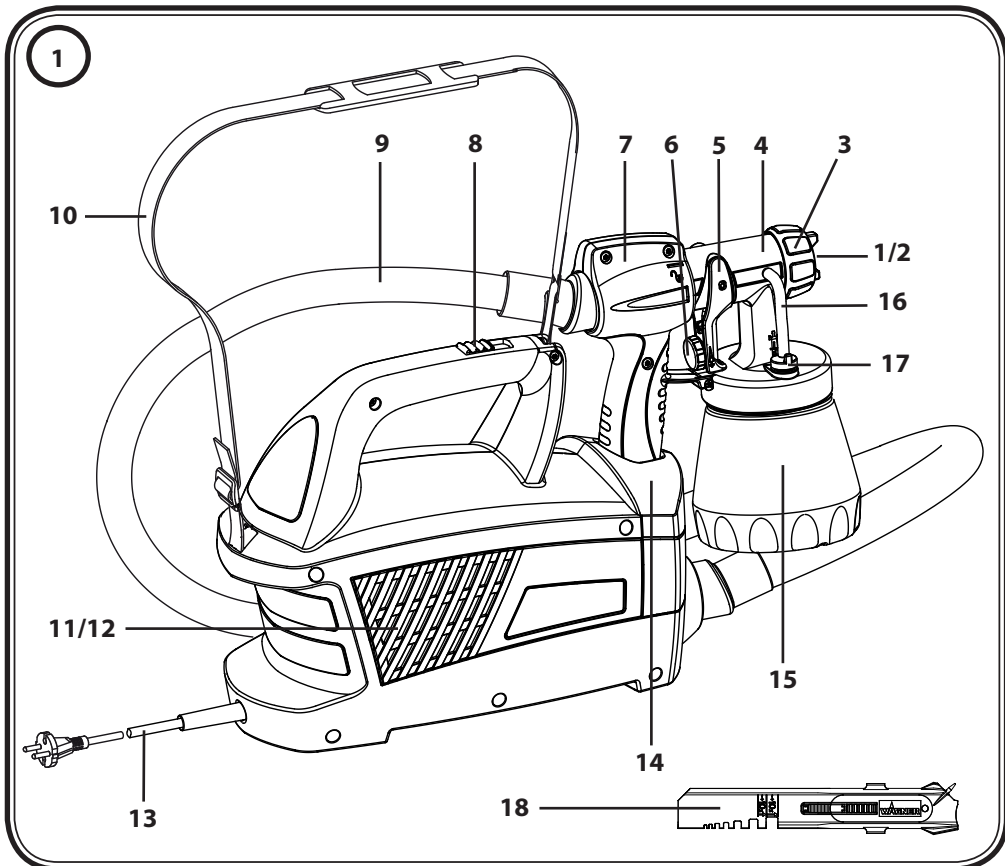

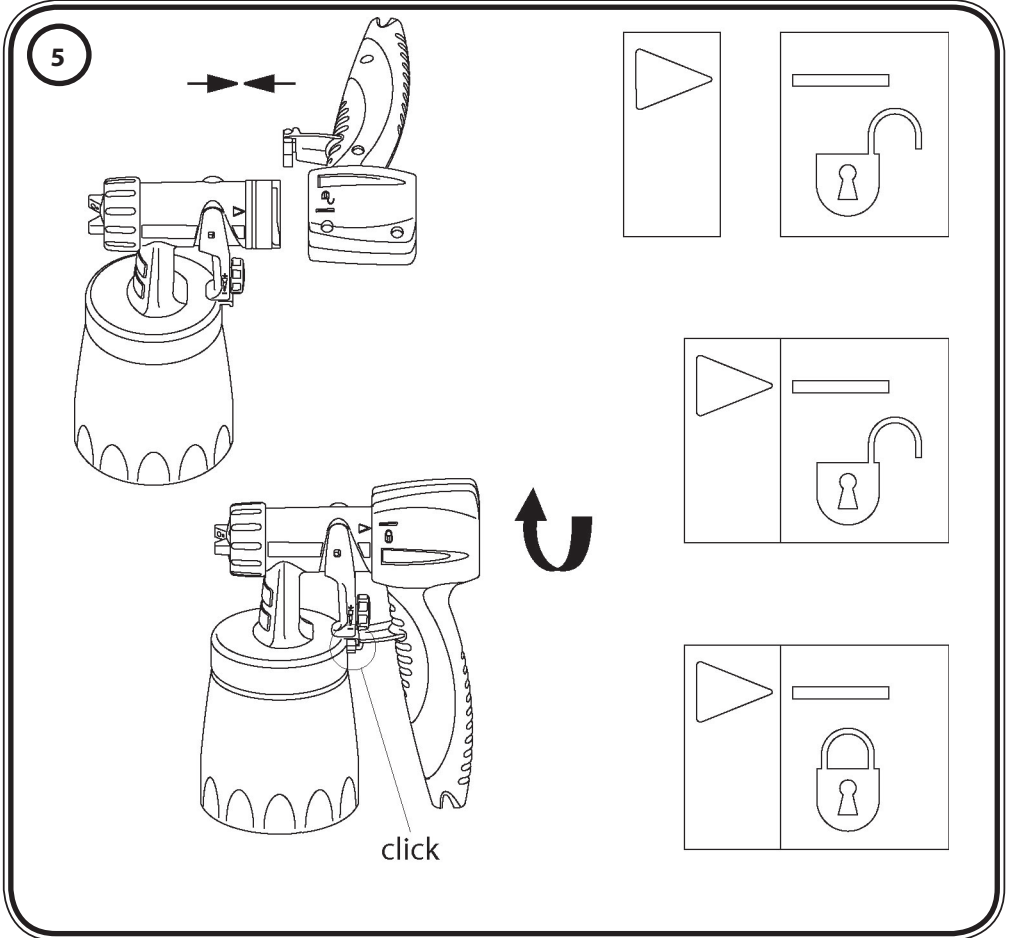
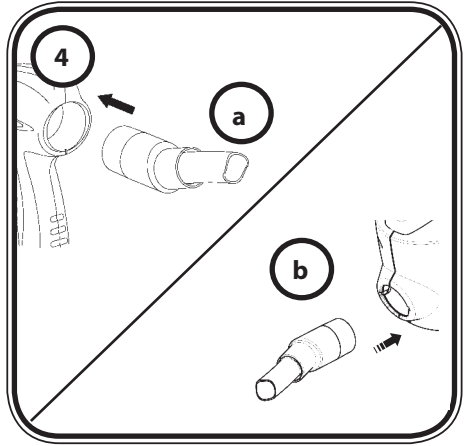
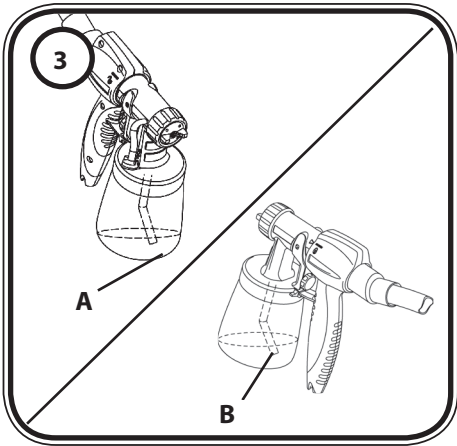

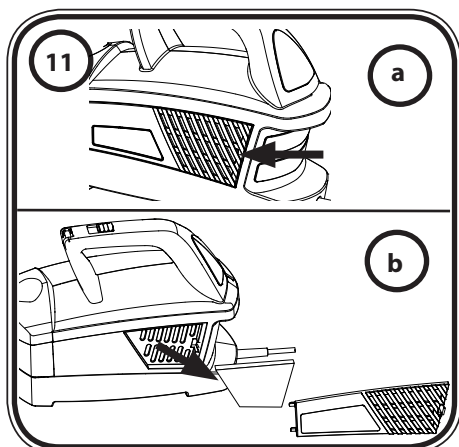
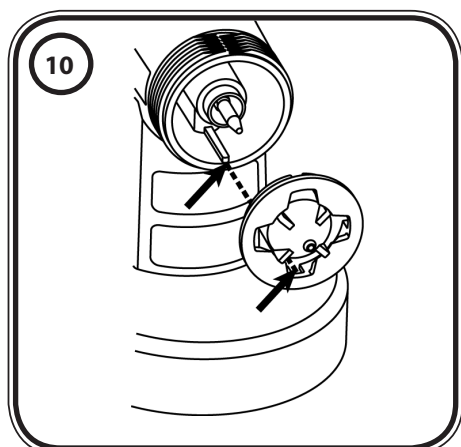
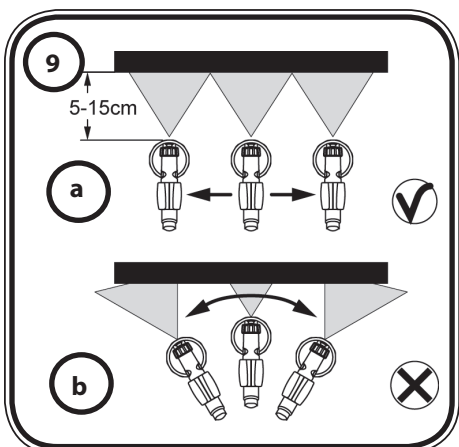
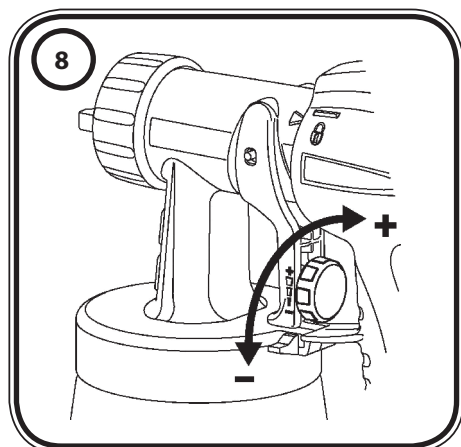
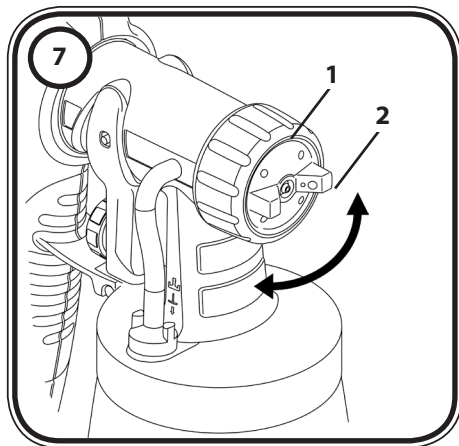
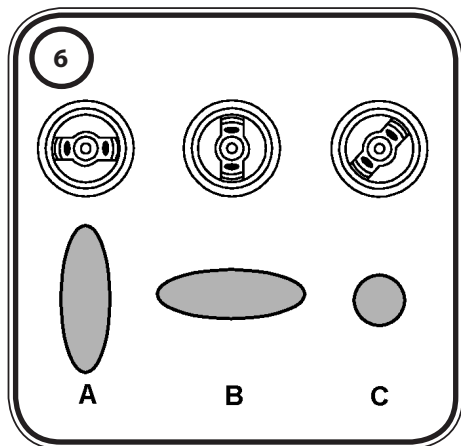

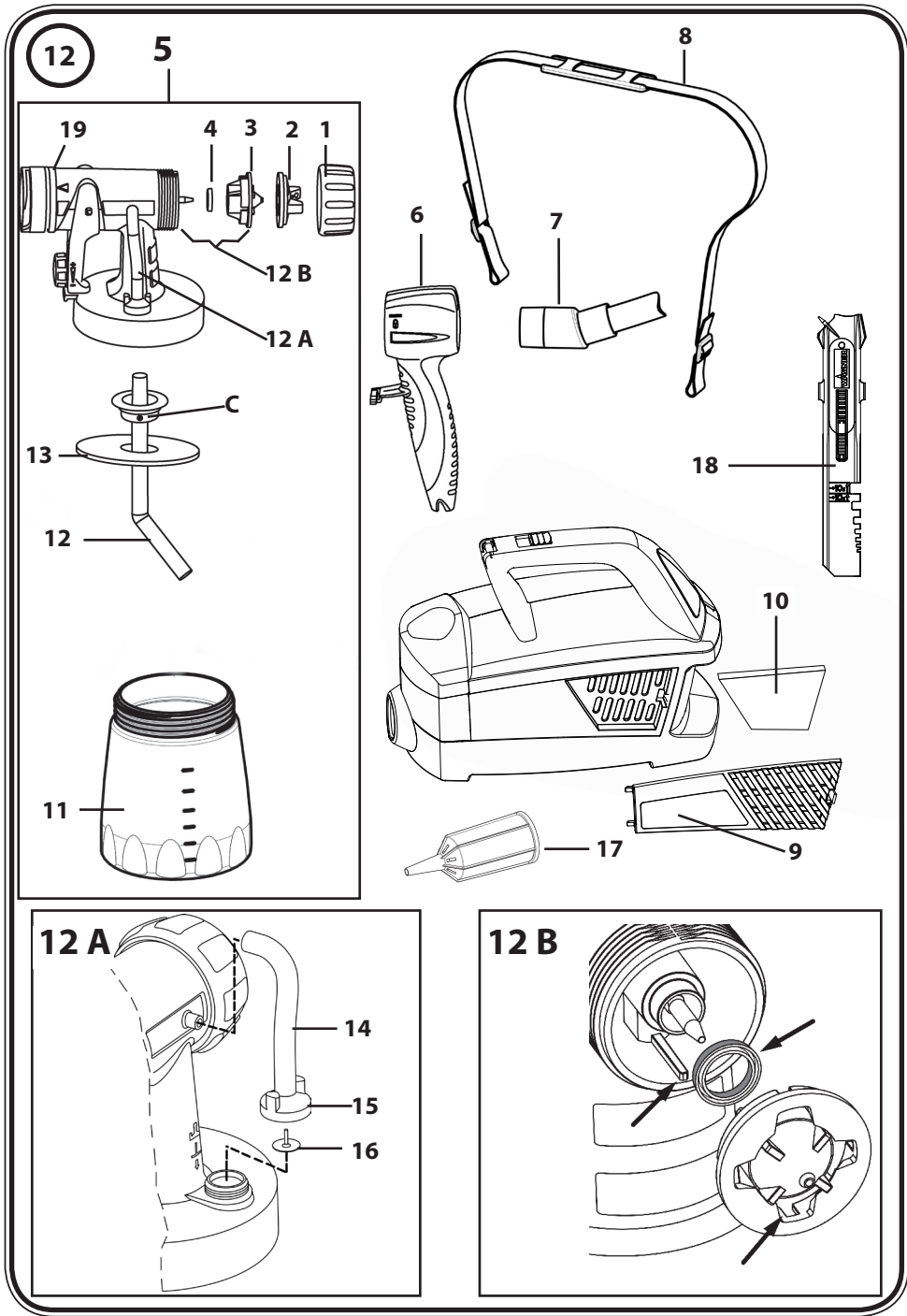

13 **Luftdüse / Airnozzle / Buse d'air / Luchtblaashulpstuk**

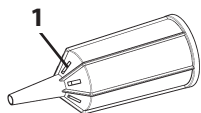

**D** .....1 - 11

**GB** .....12 - 22

**F** .....23 - 34

**NL** .....35 - 46



+



+



..... 50

## Congratulations on purchasing your WAGNER spray guns.

You have purchased a proprietary device that requires careful cleaning and care to ensure trouble-free functioning. **Read the operating instructions carefully before using the tool and observe the safety instructions. Keep the operating instructions in a safe place.**

### General Safety Instructions

#### Caution!



Read all the instructions. *Non-observance of the instructions below can cause electric shock, fire and or serious personal injuries. The term "power tool" used below covers both mains-operated power tools (with mains lead) and accumulator-operated power tools (without mains lead).*

### 1. Workplace

- a) **Keep your workplace clean and tidy.** *Untidiness and unlit working areas can lead to accidents.*
- b) **Never use the tool in hazardous areas that contain flammable liquids, gases or dusts.** *Power tools generate sparks that can ignite the dust or vapors.*
- c) **Keep children and other persons away when using the power tool.** *You can lose control of the tool if you are distracted.*

### 2. Electrical Safety

- a) **The tool plug must fit into the socket. The plug may not be modified in any form. Do not use adaptor plugs together with protective-earthed tools.** *Unmodified plugs and suitable sockets reduce the risk of an electric shock.*
- b) **Avoid physical contact with earthed surfaces such as pipes, heating elements, stoves and refrigerators.** *The risk through electric shock increases if your body is earthed.*
- c) **Keep the equipment away from rain and moisture.** *The risk of an electric shock increases if water penetrates electrical equipment.*
- d) **Do not misuse the mains lead by carrying the tool by the lead, hanging it from the lead or by pulling on the lead to remove the plug. Keep the lead away from heat, oil, sharp edges or moving tool parts.** *Damaged or twisted leads increase the risk of an electric shock.*
- e) **If you work outdoors, use only extension leads that are approved for outdoor use.** *The use of an extension lead that is suitable for outdoors reduces the risk of an electric shock.*

### 3. Safety of Persons

- a) **Be attentive. Pay attention to what you are doing and work sensibly with a power tool. Do not use the tool if you are tired or under the influence of drugs, alcohol or medication.** *Just a moment of inattentiveness while using the*

*tool can lead to serious injuries.*

- b) Wear personal safety equipment and always wear safety goggles.** *Wearing personal protective equipment, such as dust mask, non-slip safety shoes, safety helmet or ear protection, depending on the type of power tools, reduces the risk of injury.*
- c) Avoid accidental starting-up. Ensure that the switch is in the "OFF" position before inserting the plug into the socket.** *Accidents can occur if you carry the power tool while your finger is on the switch or if you connect the power tool to the power supply which it is on.*
- d) Remove setting tools or wrenches before switching on the power tool.** *A tool or wrench that is in a rotating tool part can lead to injuries.*
- e) Do not overestimate your abilities. Ensure that you are standing securely and have your balance at all times.** *This ensures that you can control the tool better in unexpected situations.*
- f) Wear suitable clothing. Do not wear wide clothing or jewelry. Keep your hair, clothes and gloves away from moving parts.** *Loose clothing, jewelry or long hair can be caught in moving parts.*
- g) This appliance is not intended for use by persons (including children) with reduced physical, sensory or mental capabilities, or lack of experience and knowledge, unless they have been given supervision or instruction concerning use of the appliance by a person responsible for their safety.** *Children should be supervised to ensure that they do not play with the appliance.*

#### 4. Careful Handling and Use of Power Tools

- a) Do not overload the tool. Use the power tool designed for the work that you are doing.** *You work better and safer in the specified performance range if you use the suitable power tool.*
- b) Do not use power tools whose switch is defective.** *A power tool that cannot be switched on or off is dangerous and has to be repaired.*
- c) Remove the plug from the socket before carrying out tool settings, changing accessories or putting the tool away.** *This precautionary measure prevents unintentional starting of the tool.*
- d) Store unused power tools so that they are inaccessible to children. Do not let persons use the tool who are not familiar with it or who have not read these instructions.** *Power tools are dangerous when they are used by inexperienced persons.*
- e) Take proper care of your tools. Check whether the moving parts function trouble-free and do not jam, whether parts are broken or damaged so that the tool function is impaired.** *Have damaged parts repaired before using the tool. Many accidents have their origin in power tools that have been maintained badly.*
- f) Use the power tool, accessories, insert tools, etc. in accordance with these instructions and in a fashion specified for this special tool type. Take the**



**working conditions and the activity to be carried out into consideration.** *The use of power tools for purposes other than the intended ones can lead to dangerous situations.*

## 5. Service

- a) Have your tool repaired only by qualified specialist personnel and only with original spare parts.** *This ensures that the tool safety is maintained.*
- b) If the supply cord is damaged, it must be replaced by the manufacturer or its service agent or a similarly qualified person in order to avoid a safety hazard.**

## Safety Instructions for Spray Guns

- **Caution!** Wear breathing equipment: Paint mist and solvent vapors are damaging to health. Always wear breathing equipment and only work in well ventilated rooms or using supplementary ventilating equipment. It is advisable to wear working clothing, safety glasses, ear protection and gloves.



### **CAUTION: DANGER OF INJURY!**

**Never point the spray stream towards human beings or animals.**

- The spray gun is to be used only for paints and solvents with a 21 °C (32° in UK) flashpoint or higher (See information on the material tin. Hazard class A II and A III permitted).
- Do not use the spray guns to spray flammable substances.
- The spray guns are not to be cleaned with flammable solvents which have a flashpoint under 21 °C.
- Caution against dangers that can arise from the sprayed substance and observe the text and information on the containers or the specifications given by the substance manufacturer.
- Do not spray any liquid of unknown hazard potential.
- The device may not be used in workplaces covered by the explosion-protection regulations.
- To avoid the hazard of explosion when spraying, provide for effective natural or artificial ventilation.
- There must be no sources of ignition such as, for example, open fires, smoke of lit cigarettes, cigars and tobacco pipes, sparks, glowing wires, hot surfaces, etc. in the vicinity during spraying.
- Ensure that no solvent vapors are sucked in by the unit. Do not spray onto the unit!
- The spray gun is not a toy; children must therefore not be allowed to handle it or play with it.
- Before working on the spray gun remove the power plug from the socket.
- Cover areas that are **not** to be sprayed. When working keep in mind that wind, for example, may transport paint mist over great distances and cause damage.
- The units may only be used with a functional valve. **If paints rises in the ventilating hose (Fig. 12 A, item 14) do not operate the unit further!** Dismantle and clean the ventilating hose, valve and diaphragm and replace the diaphragm if necessary.
- **Do not lay the spray gun.**
- The device is equipped with a thermal release which disconnects the device in case of overheating. In this case, turn off the device, remove the plug and let the device cool down for at least 1/2 hour. Eliminate the cause of heating, e.g. bent hose, soiled air filter,

slots for air intake covered.

**With original WAGNER accessories and spare parts, you have the guarantee that all safety regulations are fulfilled.**

| Technical Data        |                          |
|-----------------------|--------------------------|
| Max. viscosity:       | 130 DIN-s                |
| Power source:         | 230 V ~                  |
| Power consumption:    | 350 W                    |
| Atomizing output:     | 105 W                    |
| Double insulation:    | <input type="checkbox"/> |
| Sound pressure level: | 80 dB (A)                |
| Oscillation level:    | < 2,5 m/s <sup>2</sup>   |
| Air hose length:      | 1,8 m                    |
| Weight:               | approx. 2.8 kg           |

| Description (Fig. 1)                 |                     |
|--------------------------------------|---------------------|
| 1 Air cup                            | 10 Carrying belt    |
| 2 Nozzle                             | 11 Air filter       |
| 3 Union nut                          | 12 Air screen       |
| 4 Gun body standard spray attachment | 13 Mains lead       |
| 5 Trigger guard                      | 14 Spray gun holder |
| 6 Material volume regulation         | 15 Container        |
| 7 Handle                             | 16 Ventilating hose |
| 8 Combined ON/OFF and speed switch   | 17 Valve            |
| 9 Air hose                           | 18 Stirring rod     |

### Coating Materials Suitable for Use

Water- and solvent-based paints, finishes, primers, 2-component paints, clear finishes, automotive finishes, staining sealers and wood sealer-preservatives.

### Coating Materials Not Suitable for Use

Materials that contain highly abrasive components, facade paint, caustic solutions and acidic coating substances.

Coating materials with a flash point below 21 °C.

### The following materials can only be processed with optional accessories:

Interior wall paint (dispersions and latex paint)

### Preparation of the Coating Material

The enclosed spray attachment can be used to spray paints, varnishes and glazes that are undiluted or slightly diluted. Detailed information is available in the technical data sheet of the manufacturer (→ Internet Download).

**1.** Stir the material up and put the required amount into the paint container.

### Thinning recommendation

| Thinning recommendation   |                    |
|---|--------------------|
| <b>Sprayed material</b>   |                    |
| Glazes  | undiluted          |
| Wood preservatives, mordants, oils, disinfection agents, plant protective agents                        | undiluted          |
| Paints containing solvents and water-soluble paints, primers, vehicle coating paints, thick-film glazes | dilute by 5 - 10 % |

2. If the convey capacity is too low, add 5 - 10 % dilution step-by-step until the convey capacity fulfils your requirements.

### Start-up

Before connecting to the mains supply, be sure that the supply voltage is identical with the value given on the rating plate.

- Attach the carrying strap to the unit. **(Fig. 2)**
- Unscrew the container from the spray gun.
- Aligning suction tube. **(Fig. 3)**  
If the suction tube is positioned correctly, the container contents can be sprayed without almost any residue.  
When spraying horizontal surfaces, turn suction tube forward. (Fig. 3 A)  
When spraying objects overhead, turn suction tube back. (Fig. 3 B)
- Set the container on a sheet of paper, pour in the prepared coating material and screw the container tightly onto the spray gun.
- Connect the front part with the rear part of the gun. (Fig. 5)
- Mount the air hose (Fig. 4, a + b). Insert the air hose firmly into the connection of the unit and the gun handle. The position of the hose is not relevant.
- Insert the spray gun into the gun holder on the unit.
- Put the machine down only on a level, clean surface. Otherwise, the gun may suck in dust, etc.
- Sling on the carrying strap with the unit.
- Remove the spray gun from the gun holder and point it at the object to be coated.
- It is advisable to test spray cardboard or a similar material in order to determine the material quantity and the spray pattern.
- Press the ON/OFF switch at the device.

### Settings on the ON/OFF switch

The W670 has a multi-stage On/Off switch. This allows the power of the unit to be adjusted to the material used, in order to optimise the spray pattern and reduce the spray mist.

- Switch in Position "0" → Unit switched off
- Switch in Position "1" → Unit switched on to speed stage 1  
(for working with very thin materials such as e.g. glazes)
- Switch in Position "2" → Unit switched on to speed stage 2  
(for working with more viscous materials such as e.g. lacquers)



**For thin materials the spray mist can be reduced and energy saved by switching to speed stage 1.**

Three different spray jet settings can be chosen on the spray gun, depending on the application and target object.

### Selecting the Spray Setting

- Fig. 6 A** = horizontal flat jet → for horizontal surfaces  
**Fig. 6 B** = vertical flat jet → for vertical surfaces  
**Fig. 6 C** = circular jet → for corners, edges and hard-to-reach surfaces

### Adjusting the desired Spray Setting (Fig. 7)

With the union nut (1) slightly unscrewed, turn the air cap (2) to the desired spray-setting position (arrow). Then tighten the union nut.



**WARNING!**

**Danger of injury!**

**Never pull the trigger guard while adjusting the air cap.**

### Adjusting the Material Volume (Fig. 8)

Set the material volume by turning the regulator on the trigger guard of the spray gun

- turn to the left → lower material volume  
 + turn to the right → higher material volume

### Spray Technique

- The spray result depends heavily on the smoothness and cleanliness of the surface to be sprayed. Therefore the surface should be carefully prepared and kept free of dust.
- Cover all surfaces not to be sprayed.
- Cover screw threads or similar parts of the target object.
- It is advisable to test the spray gun on cardboard or a similar surface to find the correct setting.

**Important:** Begin spraying outside of the target area and avoid interruptions inside the target area.

The spray movement should come from the arm, not just from the wrist. This ensures that a uniform distance is maintained between the spray gun and the spray surface during the spray operation. Select a distance of 5 - 15 cm, depending on the desired spray jet width.

**Fig. 9 a:** **CORRECT** Even distance to the object.

**Fig. 9 b:** **INCORRECT** Uneven distance causes uneven coating.

- Move the spray gun evenly cross-wise or up-and-down, depending on the spray pattern setting.
- An even movement of the spray gun results in an even surface quality.
- When coating material builds up on the nozzle and air cap, clean both parts with a solvent or water.

### Interruption of Work till 4 Hours

- Turn the machine off.
- Insert the spray gun into the gun holder.
- When processing 2-component varnishes, clean the device immediately.

## Taking Out of Operation and Cleaning

**Proper cleaning is the prerequisite for problem-free operation of the paint application device. No warranty claims are accepted in case of improper or no cleaning.**

- 1) Turn the machine off. Vent the container in case of longer breaks and after the work has been terminated. This can be done by briefly turning open and then closing the container or by pulling the trigger guard and letting the paint into the original paint container.
- 2) Divide the spray gun. Press the hook (Fig. 5 "click") slightly downwards. Turn the gun front part and gun rear part against each other.
- 3) Unscrew the container. Empty any remaining coating material back into the material tin.
- 4) Preclean the container and feed tube with a brush. Clean the ventilating bore (Fig. 12, C).
- 5) Pour solvent or water into the container. Screw the container back on.

**Use only solvents with a flashpoint over 21 °C.**

- 6) Assemble the gun again (Fig. 5).
- 7) Turn on the machine and spray the solvent or water into a container or a cloth.
- 8) Repeat the above procedure until the solvent or water emerging from the nozzle is clear.
- 9) Turn off the machine and divide the spray gun.
- 10) Screw of the container and empty it. Pull out the suction tub with container seal.
 

**CAUTION!** Never clean seals, diaphragm and nozzle or air holes of the spray gun with metal objects.  
The ventilation hose and diaphragm are only solvent-resistant to a limited extent. Do not immerse in solvent, only wipe.
- 11) Pull the ventilating hose (Fig. 12 A, 14) at the top from the gun body. Screw off the valve cover (15). Remove the diaphragm (16). Clean all the parts carefully.
- 12) Unscrew the union nut and remove the air cap and nozzle. Clean the air cap, nozzle seal and nozzle with a brush and solvent or water (Fig. 12, 5).
- 13) Clean the outside of the spray gun and container with a cloth soaked in solvent or water.
- 14) Assemble the parts again (see "Assembly").

## Assembly

The unit may only be operated with an integer diaphragm (Fig. 12 A, 16). Place the diaphragm **with the pin facing upwards** on the bottom section of the valve. Also see the marking on the gun body. Place on the valve cover and screw it closed. Place the ventilating hose on the valve cover and on the nipple at the gun body.

Slide the nozzle seal (Item 4) with the groove (slot) facing forwards into the nozzle (Fig. 12 B). Put the nozzle onto the gun body and find the correct position by turning it. Put the air cap onto the nozzle and tighten it using the union nut.

Place the container seal from below on the suction tube and slide it over the collar, while turning the container seal slightly. Insert the suction tube with container seal in the gun body.

## Maintenance

Change the air filter if it is soiled. Remove air filter cover. (Fig. 11, a) The smooth side of the air filter (Fig. 11, b) must be placed towards the machine. Replace the cover on the unit until it latches.

**WARNING!** Never operate the machine without the air filter; dirt could be sucked in

and interfere with the function of the machine.

**In order to mount the gun more easily apply lubricating grease (enclosed) liberally to the O-ring at the gun front part (Fig. 12, 19).**

### Spare Parts List (Fig. 12)

| Pos. | Name   | Order No. |
|------|--|-----------|
| 1    | Union nut  | 0417 319  |
| 2    | Air cap  | 2305 129  |
| 3    | Nozzle (2.5 mm)  | 2305 131  |
| 4    | Nozzle seal  | 0417 706  |
| 5    | Perfect Spray spray attachment incl. 800 ml. container | 0417 914  |
| 6    | Handle   | 0414 240  |
| 7    | Air hose   | 0414 202  |
| 8    | Carrying belt  | 0414 204  |
| 9    | Cover  | 2306 766  |
| 10   | Air filter   | 2307 279  |
| 11   | Container with cover 800 ml                            | 0413 909  |
| 12   | Suction tube   | 0417 357  |
| 13   | Container seal   | 0417 358  |
| 14   | Ventilating hose                                       | 2304 027  |
| 15   | Valve cover  |           |
| 16   | Diaphragm  |           |
| 17   | Airnozzel  | 0414 329  |
| 18   | Stirring rod   | 2304 419  |
|      | Lubricating grease                                     | 9892 550  |

**The new CLICK&PAINT SYSTEM with additional spray attachments and accessories offers the right tool for each work.**

### Accessories (not included in the delivery)

| Name  | Order No. |
|---|-----------|
| <b>HVLP handle extension</b><br>For easier coating of ceilings and horizontal objects.  | 2307 678  |
| <b>Container with cover 800 ml</b><br>Ensures that the paint does not dry out and the solvent does not evaporate.                               | 0413 909  |
| <b>Brilliant spray attachment incl. 600 ml container</b><br>Optimised nozzle and air guidance for brilliant paint results                       | 0417 932  |
| <b>Perfect Spray spray attachment incl. 800 ml. container</b><br>For a rapid paint change. For medium- and large-scale objects and furniture.   | 0417 914  |
| <b>Small-scale spray attachment incl. 250 ml container</b><br>For filigree objects, detailed and creative work.                                 | 0417 918  |
| <b>Perfect Spray spray attachment incl. 1400 ml container</b><br>Rapid working at larger objects such as timber houses, garage doors, etc.      | 0417 917  |
| <b>Detail / Radiator spray attachment incl. 600 ml container</b><br>For inaccessible places, such as radiators, cupboard corners, recesses etc. | 0417 915  |

### Accessories (not included in the delivery)

#### WallPerfect spray attachment incl. 1800 ml container

For processing interior wall paint  
We recommend against using the WallPerfect spray attachment with the W550/W560/W610.

2301 734

**Further information about the WAGNER range of products for renovating is available under [www.wagner-group.com](http://www.wagner-group.com)**

### Air nozzle

The air nozzle can be used to remove dirt and to rapidly inflate leisure articles such as airbeds, etc. (Fig. 13).

### CAUTION!



- Wear a protective mask. Fine dust particles can enter the respiratory organs.
- Do not overload the unit! Relief openings (Fig. 13, 1) may not be blocked.
- Do not operate the air nozzle unintentionally. Check the air pressure in the object constantly. Avoid damage by removing the air nozzle at an early stage.

### Environmental protection



The appliance and accessories should be recycled in an environmentally friendly way. Do not dispose of the appliance with household waste. Support environmental protection by taking the appliance to a local collection point or obtain information from a specialist retailer.

### Important Note regarding Product Liability!

Due to an EC ordinance in effect since 01.01.1990, the manufacturer is liable for his product only if all parts originate from or were approved by the manufacturer and the devices are assembled and operated correctly. The use of other accessories and spare parts can partially or completely invalidate the liability.

## Correction of Malfunctions

| Problem                                      | Cause   | Remedy   |
|--|---|--|
| No coating material emerges from the nozzle  | <ul style="list-style-type: none"> <li>• Nozzle clogged</li> <li>• Material volume setting turned too far to the left (-)</li> <li>• No pressure build-up in container</li> <li>• Container empty</li> <li>• Feed tube loose</li> <li>• Feed tube clogged</li> </ul>  | <p>→ Clean<br/>→ Turn to the right (+)</p> <p>→ Tighten container</p> <p>→ Refill<br/>→ Insert<br/>→ Clean</p>   |
| Coating material drips from the nozzle       | <ul style="list-style-type: none"> <li>• Coating material assembly at air cap, nozzle or needle</li> <li>• Nozzle loose</li> <li>• Nozzle seal worn</li> <li>• Nozzle worn</li> </ul>   | <p>→ Clean</p> <p>→ Union nut tighten<br/>→ Change<br/>→ Change</p>  |
| Atomisation too coarse                       | <ul style="list-style-type: none"> <li>• Material volume too large</li> <li>• Material volume adjusting screw turned too far to the right (+)</li> <li>• Nozzle contaminated</li> <li>• Viscosity of coating material too high</li> <li>• Too little pressure build-up in container</li> <li>• Air filter heavily soiled</li> </ul> | <p>→ Turn material volume adjusting screw to the left (-)</p> <p>→ Clean<br/>→ Dilute further<br/>or set Stage "2"<br/>→ Tighten container</p> <p>→ Change</p> |
| Spray jet pulsates                           | <ul style="list-style-type: none"> <li>• Coating material in container running out</li> <li>• Nozzle seal worn</li> <li>• Air filter heavily soiled</li> </ul>  | <p>→ Refill</p> <p>→ Replace<br/>→ Change</p>  |
| Coating material causes "paint tears"        | <ul style="list-style-type: none"> <li>• Too much coating material applied</li> <li>• Viscosity of coating material too low</li> </ul>  | <p>→ Turn material volume adjusting screw to the left (-)</p>  |
| Too much fog of coating material (Overspray) | <ul style="list-style-type: none"> <li>• Distance to the object too large</li> <li>• Too much coating material applied</li> <li>• Material very thin</li> </ul>   | <p>→ Reduce distance</p> <p>→ Turn material volume adjusting screw to the left (-)<br/>→ dilute less<br/>or set Stage "1"</p>                                  |
| Device does not function                     | <ul style="list-style-type: none"> <li>• Device overheated</li> </ul>   | <p>→ Unplug the power plug, let the device cool down approx. 30 minutes, do not bend the hose, check the air filter, do not cover the intake slots</p>         |
| Paint in the ventilating hose                | <ul style="list-style-type: none"> <li>• Diaphragm soiled</li> <li>• Diaphragm defective</li> </ul>   | <p>→ Clean the diaphragm<br/>→ Replace the diaphragm</p>   |



## Warning

If the supply cord of this appliance is damaged, it must only be replaced by a repair shop appointed by the manufacturer, because special purpose tools are required.

**Warning:** Do not connect the blue or brown wire to the earth terminal of the plug! The wires in this mains lead are coloured in accordance with the following code:

**blue** = neutral      **brown** = live

As the colours of the wires in the mains lead of this appliance may not correspond with the coloured markings identifying the terminals in your plug, proceed as follows:

- Should the moulded plug have to be replaced, never re-use the defective plug or attempt to plug it into a different 13 A socket. This could result in an electric shock.
- Should it be necessary to exchange the fuse in the plug only use fuses approved by ASTA in accordance with BS 1362. 5 Amp fuses may be used.
- To ensure that the fuse and fuse carrier are correctly mounted please observe the provided markings or colour coding in the plug.
- After changing the fuse, always make sure that the fuse carrier is correctly inserted. With out the fuse carrier, it is not permissible to use the plug.
- The correct fuses and fuse carriers are available from your local electrical supplies stockist.

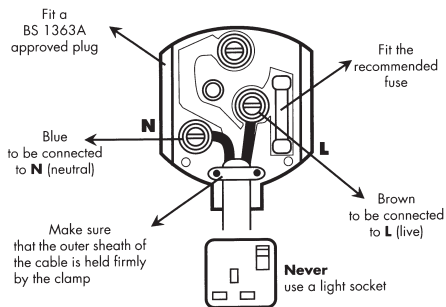

## 2 years guarantee

The guarantee runs for two years, counting from the date of sale (sales slip). It covers and is restricted to free-of-charge rectification of faults which are demonstrably attributable to the use of faulty materials in manufacture, or assembly errors; or free-of-charge replacement of the defective parts. The guarantee does not cover incorrect use or commissioning or fitting or repair work which is not stated in our operating instructions. Wearing parts are also excluded from the guarantee. The guarantee excludes commercial use. We expressly reserve the right to fulfil the guarantee. The guarantee expires if the tool is opened up by persons other than **WAGNER** service personnel. Transport damage, maintenance work and loss and damage due to faulty maintenance work are not covered by the guarantee. Under any guarantee claim, there must be proof of purchase of the tool through submission of the original receipt. Wherever legally possible, we exclude all liability for injury, damage or consequential loss, especially if the tool has been used for a purpose other than that stated in the operating instructions, commissioned or repaired other than in accordance with our operating instructions or if repairs are performed by someone who is unqualified. We reserve the right to perform any repairs in excess of those stated in our operating instructions. In case of guarantee or repair, please refer to your point of sale.

**D CE Konformitätserklärung**

Wir erklären in alleiniger Verantwortung, dass dieses Produkt den folgenden einschlägigen Bestimmungen entspricht:

2006/95/EG; 2004/108 EG; 2002/95/EG; 2002/96/EG

Angewandte harmonisierte Normen:

EN 55014-1: 2006, EN 55014-2: 2001, EN 61000-3-2: 2006,  
EN 61000-3-3: 2005, EN 60335-1: 2006, EN 50366: 2006; EN 50144-2-7: 2000

**GB CE Declaration of Conformity**

We declare under sole responsibility that this product conforms to the following relevant stipulations:

2006/95/EG; 2004/108 EG; 2002/95/EG; 2002/96/EG

Applied harmonised norms:

EN 55014-1: 2006, EN 55014-2: 2001, EN 61000-3-2: 2006,  
EN 61000-3-3: 2005, EN 60335-1: 2006, EN 50366: 2006; EN 50144-2-7: 2000

**F CE Déclaration de conformité**

Nous déclarons sous notre responsabilité que ce produit est en conformité avec les réglementations suivantes :

2006/95/EG; 2004/108 EG; 2002/95/EG; 2002/96/EG

Conforme aux normes et documents normalisés :

EN 55014-1: 2006, EN 55014-2: 2001, EN 61000-3-2: 2006,  
EN 61000-3-3: 2005, EN 60335-1: 2006, EN 50366: 2006; EN 50144-2-7: 2000

**NL CE Conformiteitsverklaring**

Wij verklaren dat dit product voldoet aan de volgende normen:

2006/95/EG; 2004/108 EG; 2002/95/EG; 2002/96/EG

En normatieve documenten:

EN 55014-1: 2006, EN 55014-2: 2001, EN 61000-3-2: 2006,  
EN 61000-3-3: 2005, EN 60335-1: 2006, EN 50366: 2006; EN 50144-2-7: 2000

**WAGNER**

J. Wagner GmbH  
Otto-Lilienthal-Str. 18  
D-88677 Markdorf



i.V. T. Jeltsch  
Vice President  
Product Strategy & Planning



i. V. J. Ulbrich  
Development Manager

**D** **J. Wagner GmbH**  
Otto-Lilienthal-Str. 18  
**D-88677 Markdorf**  
☎ Hotline 0180/1000 227  
☎ +49/75 44/505-169

**B** **Wagner Spraytech Belgie**  
Veilinglaan 58  
**1861 Meise-Wolvertem**  
☎ +32/2/2 69 46 75 ☎ +32/2/2 69 78 45

**F** **Wagner France S.a.r.l.**  
Parc de Gutenberg - Bâtiment F8  
8 voie la Cardon  
**91127 Palaiseau Cedex**  
☎ 0 825 011 111 ☎ 0169 81 72 57

**DK/S** **Wagner Spraytech Scandinavia A/S**  
Helgeshøj Allé 28  
**DK-2630 Tåstrup**  
☎ +45/43 27 18 18 ☎ +45/43 43 05 28

**CH** **J. Wagner AG**  
Industriestraße 22  
**9450 Altstätten**  
☎ +41/71/7 57 22 11 ☎ +41/71/7 57 23 23

**SK** **Phobos Corporation Spol.r.o**  
Stanicna 6, 92700 Sala  
**Slowakei**  
☎ +421/31/7 70 78 84 ☎ +421/31/7 70 22 42

**NL** **Wagner Spraytech Benelux B.V.**  
Zoonebaan 10  
**3542 EC Utrecht**  
☎ +31/30/2 41 41 55 ☎ +31/30/2 41 17 87

**GB** **Wagner Spraytech (UK) Ltd.**  
The Coach House  
2 Main Road  
**Middleton Cheney OX17 2ND**  
☎ UK-Helpline 0844 335 0517  
5 p per minute (landline)

**CZ** **M.A.T Ltd.**  
Na Roudne 176  
**301 62 Plzen**  
☎ +420 376 709 205 ☎ +420 376 709 263

**E** **J. Wagner Spraytech Ibérica S.A.**  
Ctra. N-340, Km 1245,4  
**08750 Molins de Rei (Barcelona)**  
☎ +34/93/6 80 00 28 ☎ +34/93/6 68 01 56

**SLO** Adresa servisa:  
**GMA Elektromehanika d.o.o.**  
Cesta Andreja Bitenca 115,  
**Ljubljana 1000/Slowenien**  
☎ +386(1)/583 83 04 ☎ +386(1)/518 38 03

**H** Magyarországi szerviz  
**Hondimpex KFT.**  
Kossuth L. u. 48-50  
**8060 Mór**  
☎ +36(-22)/407 321 ☎ +36(-22)/407 852

**PL** **PUT Wagner Service**  
ul. E. Imieli 14  
**41-605 Swietochlowice**  
☎ +48/32/2 45 06 19 ☎ +48/32/2 41 42 51

**HR** Adresa servisa:  
**EL-ME-HO**  
Horvatinčičev put 2  
**10436 Rakov Potok/Kroatien**  
☎/☎ +385(-1)65 86 - 028

**AUS** **Wagner Spraytech Australia Pty. Ltd.,**  
14-16 Kevlar Close,  
**Braeside, VIC 3195/Australia**  
☎ +61/3/95 87 20 00 ☎ +61/3/95 80 91 20

[www.wagner-group.com](http://www.wagner-group.com)

Irrtümer und Änderungen vorbehalten.  
Not responsible for errors and changes.  
Sour réserves d'erreurs et de modifications.  
Fouten en wijzigingen voorbehouden.