

Family First™

CARBON MONOXIDE ALARM MODEL: FFCM9VH

User's Manual

Please read and save this manual



FEATURES

- DC operated carbon monoxide alarm
- Insect proof
- Test / Hush button
- High and stable sensitivity
- With quick fix mounting bracket for easy installation
- Fitting and battery tamper-resist feature
- LED operation indicator
- Low-battery and battery missing warning indicator
- Auto reset after the CO is clear

SPECIFICATIONS

- Model Number: FFCM9VH
- Detection Type: Electrochemical
- Power Source: 9V DC Battery
- Standby Current: <30uA
- Alarm Current: <20mA
- Alarm Level: 50ppm (Between 60-90 min)
100ppm (between 10-40 min)
300ppm (Between<3min.)
- Alarm Sound Level: 85 Decibels at 3 meters
- Operation Temperature: 5°C to 38°C
- Ambient Humidity: 15% to 90% Relative Humidity

INFORMATION ABOUT CARBON MONOXIDE ALARMS

1. WHAT IS CARBON MONOXIDE?

Carbon monoxide is a colorless, odorless and tasteless poison gas that can be fatal when inhaled. CO binds to the hemoglobin in the blood and inhibits its capacity to carry oxygen. CO kills hundreds of people each year and injures many more because it is difficult to be detected with the human senses. In high concentrations, CO can kill in minutes.

2. SOURCES OF CARBON MONOXIDE

Inside your home, appliances used for heating and cooking are the most likely sources of CO. Vehicles running in attached garages can also produce dangerous levels of CO.

CO can be produced when burning any fossil fuel, such as gasoline, propane, natural gas, oil and wood. It can be produced by any fuel-burning appliance that is malfunctioning, improperly installed, or not ventilated correctly, such as:

- Automobiles, furnaces, gas ranges/stoves, gas clothes dryers, water heaters, portable fuel burning space heaters and generators, fireplaces, wood-burning stoves and certain swimming pool heaters.
- Blocked chimneys or flues, back drafts and changes in air pressure, corroded or disconnected vent pipes, loose or cracked furnace exchangers.
- Vehicles and other combustion engines running in an open or closed garage, attached or near a home.
- Burning charcoal or fuel in grills and hibachis in an enclosed area.

3. CONDITIONS THAT CAN RESULT IN TRANSIENT CO SITUATION IN THE HOME:

Excessive spillage or reverse venting of fuel-burning appliances caused by outdoor ambient conditions, such as, wind direction and/or velocity, including high gusts of wind, heavy air in the vent pipes (Cold/humid air with extended periods between cycles).

- Negative pressure resulting from the use of exhaust fans.
- Simultaneous operation of several fuel-burning appliances competing for limited internal air.
- Vent pipe connections vibrating loose from clothes dryers, furnaces, or water heaters.
- Obstructions in, or unconventional, vent pipe designs which can amplify the above situations.
- Extended operation of unvented fuel-burning devices (range, oven, fireplace, etc.).
- Temperature inversions which can trap exhaust gases near the ground.
- Vehicle idling in an open or closed garage, or near a home.

4. SYMPTOMS OF CO POISONING

To be safe, know the possible sources of CO in your home. Keep fuel-burning appliances and their chimneys and vents in good working condition. Learn the early symptoms of exposure, and if you suspect CO poisoning, move outside to fresh air and get emergency help. Your first line of defense is an annual inspection and regular maintenance of your appliances. Contact a licensed contractor or call your local utility company for assistance.

35 ppm - The maximum allowable concentration for continuous exposure for healthy adults in any 8 hour period.

200 ppm - Slight headaches, fatigue, dizziness, nausea after 2-3 hours.

400 ppm - Frontal headaches within 1-2 hours, life threatening after 3 hours.

800 ppm - Dizziness, nausea and convulsions within 45 minutes. Unconsciousness within 2 hours and death within 3 hours.

1600 ppm - Headache, dizziness and nausea within 20 minutes. Death within 1 hour.

6400 ppm - Headache dizziness and nausea within 1-2 minutes.

The following symptoms related to CO POISONING and are to be discussed with ALL members of the household:

Mild Exposure: Slight headache, nausea, vomiting, fatigue (often described as "flu-like" symptoms)

Medium Exposure: Severe throbbing headache, drowsiness, confusion, fast heart rate.

Extreme Exposure: Unconsciousness, convulsions, cardio respiratory failure, death.

Many cases of reported CARBON MONOXIDE POISONING indicate that while victims are aware they are not well. They become so disoriented they are unable to save themselves by either exiting the building or calling for assistance. Young children and household pets are typically the first affected.

5. IMPORTANT SAFEGUARDS

Installation of your CO alarm is only one step in your safety plan. Educate yourself and family to the sources and symptoms of CO poisoning and how to use your carbon monoxide alarm:

- Test your CO alarm weekly
- Replace the battery immediately once depleted
- Buy appliances accepted by a recognised testing laboratory
- Install the appliances properly, following the manufacturer's instructions
- Have installations done by professionals
- Have your appliances checked regularly by a qualified serviceman
- Clean chimneys and flues yearly
- Make regular visual inspections of all fuel burning appliances
- Check appliances for excessive rust and scaling
- Open windows when a fireplace or wood burning stove is use
- Be aware of CO poisoning symptoms

DO NOT:

- Burn charcoal inside your home, RV, camper, tent or cabin
- Install, convert or service fuel burning appliances without proper knowledge, skill and expertise
- Use a gas range, oven or clothes dryer for heating
- Operate unvented gas burning appliances using kerosene or natural gas in closed room
- Operate gasoline powered engines indoors or in confined areas
- Ignore a safety device when it shuts an appliance
- Ignore any warning from your CO alarm
- Do not barbecue indoors, or in an attached garage

CO ALARM PLACEMENT

Typical single-story home

For minimum protection you should fit an alarm in the bedrooms or in the hallway of sleeping areas. Place it as near to the sleeping areas as possible and ensure the alarm is audible when the bedrooms are occupied.

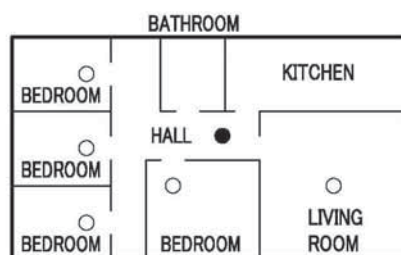

Typical Multi-story or split level home

For minimum protection, you should fit at least one alarm on each floor.

KEY: ● Maximum Protection
○ Minimum Protection

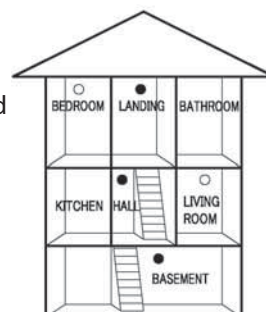

Note: For maximum protection an alarm should be fitted in or near every room that contains a fuel-burning appliance such as any central heating boilers, gas fires, room heaters, water heaters, cookers, grills, etc.

CAUTION: CO alarms can only sense CO that reaches the unit's sensor. It's possible that CO may be present in other areas without reaching the alarm.

This carbon monoxide alarm is designed to detector carbon monoxide gas from ANY source of combustion. It is NOT designed to detect smoke, fire or any other gas.

IMPORTANT CO ALARM PLACEMENT AND EXCEPTION INFORMATION

Carbon Monoxide has a similar density to warm air and can be fitted in various locations. If fitted to a wall, it should be fitted at least 1.5 meters (5 feet) above the floor level and at least 1.85 meters (6 feet) from the appliance to ensure maximum effectiveness.

DO NOT INSTALL CO ALARMS

Improper location can affect the sensitive electronic components in this alarm. To avoid causing damage to the unit, to provide optimum performance, and to prevent unnecessary nuisance alarms:

1. The alarm is not to be located within 1.5m (5 feet) of any cooking appliance.
2. Situations where the temperature may fall below 5°C or rise above 38°C .
3. In a damp or humid area such as near bathrooms or in shower areas.
4. Any area where high levels of dusty, dirty or greasy emissions could contaminate or clog the sensor.
5. Behind drapes or furniture.
6. In the path of air discharged from a furnace/air conditioning vent or ceiling fan.
7. Outside the building.
8. Directly above a sink or cooker.

WARNING: This CO alarm is designed for indoor use only. Do not expose to rain or moisture. It will not protect against the risk of CO poisoning when the battery has drained. DO NOT open or tamper with the alarm as this could cause malfunction.

HOW TO INSTALL THIS CARBON MONOXIDE ALARM

This CO alarm is powered by a battery and requires no additional wiring. It can be installed either on the ceiling or the wall using the fixings provided.

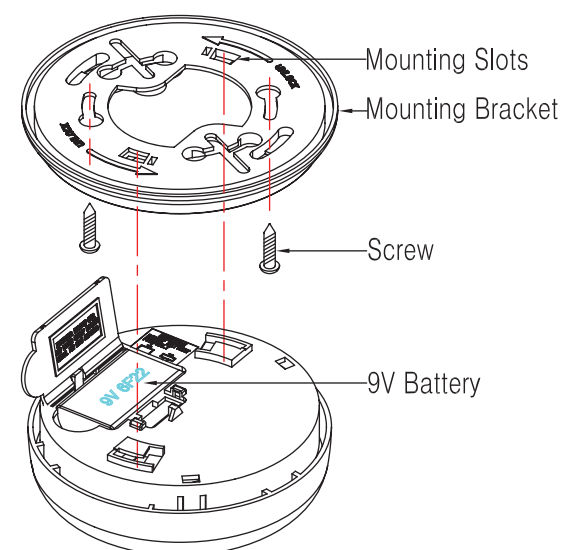
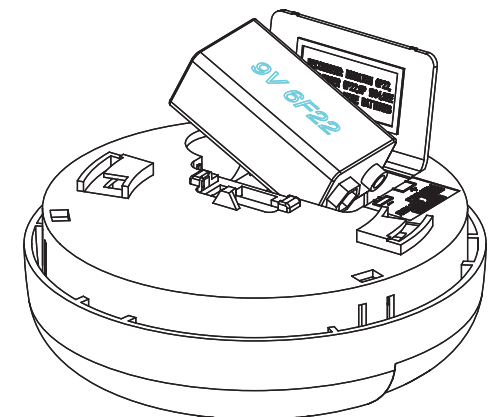

WARNING: CO alarm installation must be in accordance with the requirements of the national electrical code and any local codes that may apply and by a competent person.

1. From back of CO alarm, remove the mounting plate by turning it counterclockwise. (To later engage tamper-resist feature, twist out and set aside one of the pins molded into plate. Both pins are exactly the same.)

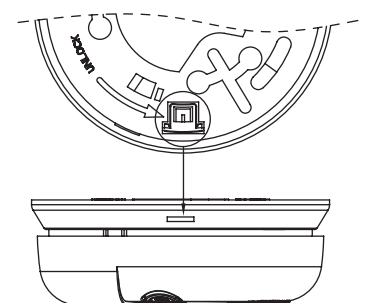

- Secure plate to ceiling or wall with mounting screws.
- Lift open battery pocket door.
- Connect new 9-volt battery to battery connector inside battery pocket. Be sure battery is securely connected. Red LED may blink briefly when battery is installed.
- Close battery pocket door, snapping it into place.
- Position CO alarm to mounting plate and turn clockwise to lock into place. To engage tamper-resist feature, insert pin into notch on edge of CO alarm after alarm is properly positioned in base.
- Push test button to test CO alarm. See TESTING THE CO ALARM.

OPERATING YOUR CO ALARM

Normal Operation

When no carbon monoxide is present, the green light flashes ONCE A MINUTE and is an indication that your alarm is powered and functional.

Alarm Condition

When the unit detects dangerous levels of CO, Red LED flashes rapidly and alarm sounds loudly (repeating 4 beeps, pause). This will continue as long as there is a dangerous level of CO present. Should the CO levels return to normal, the unit will stop beeping.

CO LEVEL (PPM) RESPONSE TIME (MIN)

| | |
|-----|-------|
| 50 | 60-90 |
| 100 | 10-40 |
| 300 | <3 |

WARNING: This product may not alarm at low carbon monoxide levels. Individuals with medical problems may consider using warning devices which provide audible concentrations under 30 ppm.

Hush Feature

The Hush Feature is for your convenience only and will not correct a CO problem. Always check your home for a potential problem after any alarm. Failure to do so can result in injury or death.

NEVER remove the batteries from your CO Alarm to silence the horn. Use the silence feature. Removing the batteries removes your protection! See "What To Do If The Alarm Sounds" for details on responding to an alarm.

The Hush Feature is intended to temporarily silence your CO Alarm's alarm horn while you correct the problem—it will not correct a CO problem. While the alarm is silenced it will continue to monitor the air for CO. When CO reaches alarm levels the alarm will sound—repeating horn pattern: 4 beeps, a pause, 4 beeps, etc. Press and hold the Test/Silence button until the horn is silent. The initial Silence cycle will last approximately 4 minutes.

NOTE: After initial 4-minute Silence cycle, the CO Alarm re-evaluates present CO levels and responds accordingly. If CO levels remain potentially dangerous or start rising higher the alarm will start sounding again.

While the detector is silenced:

If the CO Alarm...

Is silent for only 4 minutes, then starts sounding loudly, 4 beeps, pause, 4 beeps, pause

This means...

CO levels are still potentially dangerous.

If the CO Alarm...

Remains silent after you pressed the Test/Silence button

This means...

CO levels are dropping.

Low Battery Signal

The light continues to flash (RED) and the horn also "chirps" once every minute. This warning should last for up to 30 days, but you should replace the batteries as soon as possible.

NOTE: With normal use the batteries will last for 1 year minimum. However, battery life will be reduced if either a fault occurs with the battery or the alarm remains in alarm for long periods of time.

Unit Malfunction

Your CO alarm performs an internal self-diagnosis to make sure that it is functioning properly. If the unit has detected an error, the light flashes (RED) and the horn sounds 3 quick "chirps" every minute. CO Alarm needs to be replaced.

If your CO alarm sounder is beeping, and you are not sure if it is a CO alarm or malfunction alert, reset the alarm, open windows for ventilation, turn off fuel-burning appliance (like kerosene or oil heaters, furnaces, wood-burning stoves, water heaters, or other fossil-fuel burning appliances)

Never ignore a CO unit's alarm. A true alarm is an indication of potentially dangerous levels of carbon monoxide. CO alarms are designed to alert you to the presence of carbon monoxide before an emergency, before most people would experience symptoms of carbon monoxide poisoning, giving you time to resolve the problem calmly.

TESTING THE CO ALARM

Test the CO Alarm once a week. If the CO Alarm ever fails to test correctly, have it replaced immediately! If the CO Alarm is not working properly, it cannot alert you to a problem.

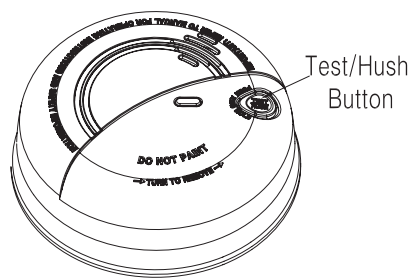

DO NOT stand close to the Alarm when the horn is sounding. Exposure at close range may be harmful to your hearing. When testing, step away when horn starts sounding. Push and hold the Test/Silence button on the cover until the LED flashes. The alarm horn will sound 4 beeps, a pause, then 4 beeps. The ALARM (RED) light will flash. The alarm sequence should last 5-6 seconds. If it does not alarm, make sure fresh batteries are correctly installed, and test it again. If the unit still does not alarm, replace it immediately.

If the alarm does not test properly:

1. Make sure that fresh batteries are installed correctly.
2. Be sure the Alarm is clean and dust-free.
3. Install fresh 9V batteries* and test the Alarm again.

*For a list of acceptable replacement batteries, see "CHOOSING A REPLACEMENT BATTERY."

WARNING: DO NOT try fixing the Alarm yourself – this will void your warranty! If the CO Alarm is still not operating properly, and it is still under warranty, please see "How to Obtain Warranty Service" in the Limited Warranty. Install a new CO Alarm immediately.

The Test/Hush button is the only proper way to test the CO Alarm. NEVER use vehicle exhaust! Exhaust may cause permanent damage and voids your warranty.

MAINTAINING YOUR CO ALARM

Your alarm will alert you to potentially hazardous CO concentrations in your home when maintained properly. To maintain your alarm in proper working order, it is recommended that you:

1. Test your alarm at least once a week.
2. Clean your CO alarm regularly to prevent dust build up. See "CLEAN THE CO ALARM"

BATTERY REPLACEMENT

Replace battery at least once a year or immediately when the low battery signal sounds once a minute.

This low voltage warning will be given for at least 30 days. Batteries should be replaced regularly as necessary.

WARNING: Use the recommended batteries as specified in this manual.

Do not use rechargeable batteries.

CAUTION: Incorrectly fitted batteries may cause an explosion

1. Separate the pin from the CO alarm. Turn the alarm counterclockwise to detach it from the mounting plate.
2. Gently pull down CO alarm.
3. Remove battery from the compartment.
4. Insert a new 9-volt battery to connector. NOTE POLARITY OF CONNECTIONS. Ensure the metal tab is fully depressed when the battery has been fitted.
5. Using the Push-to-Test button, test the CO alarm to verify the 9V DC battery. See "TESTING THE CO ALARM"
6. Reattach the CO alarm to the mounting plate by turning smoke alarm clockwise until it snaps into place.
7. Insert the two tamperproof tabs back into the notch on edge of CO alarm after alarm is properly positioned in base.
8. Turn on power supply and test the alarm using the push-to-test button. See "TESTING THE CO ALARM"

Note: If the unit fails to operate when being tested, Please refer to "TROUBLESHOOTING".

Do not attempt to remove the cover to solve the problem yourself. This will void your warranty.

CHOOSING A REPLACEMENT BATTERY:

The unit requires one standard 9V battery. The following batteries are acceptable as replacements:

Golden Power #6F22, Megaton #6F22; New Leader #6F22; Gold Peak #1604; Eveready #522, #1222.

CLEAN THE CO ALARM

Clean the CO alarm at least once a month to remove dust, dirt, or debris. Using the soft brush or wand attachment to a vacuum cleaner, vacuum all sides and cover of CO alarm. Be sure all the vents are free of debris. If necessary, use a damp cloth to clean CO alarm cover.

IMPORTANT: Do not attempt to remove the cover to clean inside the CO alarm. This will void your warranty.

NOTE:

- ▶ Never use detergents or solvents to clean the alarm. Chemicals can permanently damage or temporarily contaminate the sensor.
- ▶ Avoid spraying air fresheners, hair spray, paint or other aerosols near the alarm.
- ▶ Do not paint the alarm. Paint will seal the vents and interfere with proper sensor operation.
- ▶ Move the CO Alarm to a remote location, to prevent possible damage to or contamination of the sensor if you will be staining or stripping wood floors or furniture, painting, wall-papering, or using aerosols or adhesives.

WARNING: Reinstall the CO Alarm as soon as possible to assure continuous protection.

The following is a list of substances that at high levels can damage the sensor or cause temporary false alarm that is not a carbon monoxide alarm.

Ethylene, ethanol, alcohol, iso-propanol, benzene, toluene, ethyl acetate, hydrogen, hydrogen sulfide and sulfur dioxide. Also most aerosol sprays, alcohol based products; paint, thinner, solvent, adhesive, hair spray, after shave, perfume, auto exhaust (cold start) and some cleaning agents.

WHAT TO DO IF THE ALARM SOUNDS

Actuation of your CO alarm indicates the presence of carbon monoxide (CO), which can kill quickly. If the alarm sounds:

1. Operate reset button
2. Immediately move to fresh air-outdoors or by an open door/window. Make sure that all persons are alerted. Do not re-enter the premises nor move away from the open door/window until emergency services responders have arrived, the premises have been aired out, and your alarm remains in its normal condition.
3. Call your emergency services
4. After following steps 1-3, if your alarm reactivates within a 24 hour period, repeat steps 1-3, and call a qualified appliance technician to investigate for sources of CO from fuel burning equipment and appliances, and inspect for proper operation of this equipment. If problems are identified during this inspection have the equipment serviced immediately.

Note any combustion equipment not inspected by the technician and consult the manufacturer's instructions, or contact the manufacturers directly for more information about CO safety and the equipment. Make sure that motor vehicles are not, or have not been, operating in a garage attached or adjacent to the residence. Never restart the source of a CO problem until it has been corrected.

WARNING: Never ignore the sound of the alarm! If the alarm is sounding, pressing the test/reset button will terminate the alarm. If the CO condition that caused the alert in the first place continues, the alarm will reactivate. If the unit alarms again within six minutes, it is sensing high levels of CO which can quickly become a dangerous situation.

THREE YEAR LIMITED WARRANTY

Master Distributors Pty Ltd warrants to the original consumer purchaser each new smoke alarm to be free from defects in material and workmanship under normal use and services for a period of three(3) years from the date of purchase. Master Distributors Pty Ltd agrees to repair or replace, at its option, any defective CO Alarm provided it is returned personally or by prepaid delivery with a copy of proof of purchase. Do not post.

This warranty does not cover damage resulting from accidents, misuse or abuse or lack of reasonable care of the product. The purchaser's attention is drawn to rights it may have under the Trade Practices Act 1974 and similar state and territory legislation which cannot be excluded.

Subject to those non-excluded rights and provisions and the above warranty, Master Distributors Pty Ltd, will not be liable for any injury to persons or damage to property or for any special direct or indirect or consequential loss or damage whatsoever and whether as a result of negligence or fault on the part of Master Distributors Pty Ltd. or its servants, agents, suppliers and contractors or otherwise arising out of or resulting from, whether directly or indirectly, the use, installation or maintenance of the CO alarm and any warranties or representations are excluded unless given by Master Distributors Pty Ltd in writing. The 9 volt battery included with this CO Alarm is excluded from the Master Distributors Pty Ltd, 3 year Limited Warranty. If this CO Alarm is installed for use by others, please leave this document or a copy for the end user.



31 Dunlop Road Mulgrave Victoria 3170 Australia
www.masterdistributors.com.au

| TROUBLE SHOOTING GUIDE | | |
|---|--|--|
| PROBLEM... | THIS MEANS... | YOU SHOULD... |
| The light continues to flash (RED) and the horn "chirps" once every minute. | Low battery warning. | Install a new 9V battery. |
| The light flashes (RED) and the horn sounds 3 quick "chirps" every minute. | MALFUNCTION SIGNAL. CO Alarm needs to be replaced. | CO Alarms under warranty should be returned to distributor for replacement. |
| CO Alarm goes back into alarm 4 minutes after you press the Test/Hush button. | CO levels indicate a potentially dangerous situation. | IF YOU ARE FEELING SYMPTOMS OF CO POISONING, EVACUATE your home and call your local Fire Authority. If not, press the Test/Hush button again and keep ventilating your home. |
| CO Alarm sounds frequently even though no high levels of CO are revealed in an investigation. | The CO Alarm may be improperly located. Refer to "CO ALARM PLACEMENT." | Relocate your alarm. If frequent alarms continue, have home rechecked for potential CO problems. You may be experiencing an intermittent CO problem. |